

Description

The AVQ300-48S12B is a single output DC-DC converter with standard quarter-brick outline and pin configuration. It delivers up to 25A output current with 12V output voltage, which makes it an ideal choice for small space, IBA applications. The converter can achieve ultra high efficiency of 94.5%. For most applications, a heat sink is not required.



Operational Features

- Up to 25A output current
- Industry standard quarter brick foot print
- Basic isolation
- Ultra high efficiency: 94.5% at 12V full load ($V_{in}=48Vdc$)
- Improved thermal performance
- High power density
- Low output noise
- No minimum load requirement
- wide input voltage of 36V~75V
- RoHS compliant

Control Features

- Remote control function (negative or positive logic optional)
- Remote output sense
- Trim function: 90% ~ 110%

Protection Features

- Input under voltage lockout
- Output over current protection
- Output over voltage protection
- Over temperature protection

Mechanical Features

- Industry standard Quarter-brick pin-out outline
- Choice of short pins or long pins
- Pin length option: 3.8mm, 4.8mm, 5.8mm

Safety & EMC

- Meets safety standards UL 60950-1, CSA-C22.2 NO. 60950-1, IEC/EN 60950-1 and GB4943.
- Approved by UL and TUV.
- Meets 2006/95/EEC and 93/68/EEC directives which facilitates CE marking in user's end product
- Meets conducted emission's requirements of EN55022 Class B with external filter.

Electrical Characteristics

Full operating ambient temperature range is -40°C to +85°C.

Specifications are subject to change without notice.

Parameter		Min.	Typ.	Max.	Unit	Notes & Conditions
Absolute max. ratings						
Input voltage	Non-operating			100	V	100ms
	Operating			80	V	Continuous
Operating temperature		-40		85	°C	
Storage temperature		-55		125	°C	
Voltage at remote ON/OFF pin		-0.3		12	V	
Input characteristics						
Operating input voltage range		36	48	75	V	
Input under-voltage lockout	Turn-on voltage threshold		35	36	V	
	Turn-off voltage threshold	32	34		V	
	Lockout voltage hysteresis	1		3	V	
Max. input current				12	A	36V _{in} , full load
No-load input current				0.2	A	
Standby Input current			0.01	0.1	A	Remote OFF
Input reflected ripple current				150	mA	Through 12µH inductor; Figure 3
Recommended input fuse				15	A	Fast blow external fuse recommended; Figure 10
Input filter component values (C/L)			8.8\1		µF\µH	Internal values
Recommended external input capacitance		100			µF	Low ESR capacitor recommended; Figure 10
Output characteristics						
Output voltage set point (standard option)		11.80	12	12.20	V	48V _{in} , full load
Output voltage line regulation				0.2	%	
				24	mV	
Output voltage load regulation				0.2	%	
				24	mV	
Output voltage temperature regulation				0.02	%/°C	

Parameter		Min.	Typ.	Max.	Unit	Notes & Conditions
Total output voltage range		11.70	12	12.30	V	Over sample, line, load, temperature & life
Output voltage ripple and noise				150	mVpp	Figure 2 20MHz bandwidth; Figure 14
Operating output current range		0		25	A	
Output DC current-limit inception		26.25		32.5	A	Hiccup: auto-restart when over-current condition is removed
Output capacitance		470	1000	10000	μ F	High frequency and low ESR is recommended
Dynamic characteristics						
Dynamic response	50% ~ 75% ~ 50% $I_{o,max}$, 0.1A/ μ s			600	mV	Figure 4 Test condition: 25°C, nominal input voltage, see Figure 14
	Settling time			700	μ s	Recovery to within 1% $V_{o,nom}$
	50% ~ 75% ~ 50% $I_{o,max}$, 1A/ μ s			1200	mV	Figure 5 Test condition: 25°C, nominal input voltage, see Figure 14
	Settling time			700	μ s	Recovery to within 1% $V_{o,nom}$
Turn-on transient	Rise time			100	ms	Full load, Figure 6
	Turn-on delay time			150	ms	
	Output voltage overshoot			5	% V_o	
Efficiency						
100% load			94.5		%	Figure 1
50% load			95		%	Figure 1

Electrical Characteristics (Continued)

Parameter	Min.	Typ.	Max.	Unit	Notes & Conditions
Isolation characteristics					
Isolation voltage (conditions: 1mA for 60s, slew rate of 1500V/10s)	1500			V	Basic insulation, pollution degree 2, input to output
	1500			V	Basic insulation, pollution degree 2, input to baseplate
	500			V	Functional insulation, pollution degree 2, output to baseplate
EMC characteristics					

Parameter	Min.	Typ.	Max.	Unit	Notes & Conditions	
ESD		B			IEC/EN61000-4-2 Level 3	
EFT ^[1]		B			IEC/EN61000-4-4 Level 3	
Surges ^[1]		B			IEC/EN61000-4-5 Line to Ground(earth): 600V Line to Line: 600V	
Conducted disturbances immunity		A			IEC/EN61000-4-6 Level 2	
DC voltage dips, short interruption, variation		B			EN61000-4-29	
Conducted Emission					EN55022, DC Input, Class B	
Feature characteristics						
Switching frequency	135	145	155	kHz		
Remote ON/OFF control (positive logic)	Off-state voltage	-0.7		1.2	V	See Figure 11
	On-state voltage	3.5		12	V	
Remote ON/OFF control (negative logic)	Off-state voltage	3.5		12	V	
	On-State Voltage	-0.7		1.2	V	
Output voltage trim range	10.8		13.2	V	See <i>Trim Characteristics</i> of <i>Application Note</i>	
Output voltage remote sense range			0.6	V		
Output over-voltage protection	125		150	%Vo,nom	Hiccup: auto-restart when over-voltage condition is removed	
Over-temperature shutdown		100		°C	Auto recovery; OTP test point: see Figure 16	
Over-temperature hysteresis		10		°C		
Reliability characteristics						
Calculated MTBF (telcordia)		1.5		10 ⁶ h	Telcordia SR-332-2006; 80% load, 300LFM, 40°C T _a	

Note 1:

Criterion A: Normal performance during and after test.

Criterion B: Normal performance after test, automatic restart is allowed after test.

For EFT and Surges, system reset is no allowed.

Criterion C: Normal performance after test, the module can be restarted manually after test.

Normal performance means that output noise (Vpp) meet the requirement of the specifications.

Qualification Testing

Parameter	Unit (pcs)	Test condition
Halt test	4 ~ 5	$T_{a,min}-10^{\circ}\text{C}$ to $T_{a,max}+10^{\circ}\text{C}$, 5°C step, $V_{in}=\text{min}$ to max , 0 ~ 105% load
Vibration	3	Frequency range: 5Hz ~ 20Hz, 20Hz ~ 200Hz, A.S.D: $1.0\text{m}^2/\text{s}^3$, -3db/oct, axes of vibration: X/Y/Z Time: 30min/axis
Mechanical shock	3	30g, 6ms, 3axes, 6directions, 3time/direction
Thermal shock	3	-40°C to 100°C , unit temperature 20cycles
Thermal cycling	3	-40°C to 55°C , temperature change rate: $1^{\circ}\text{C}/\text{min}$, cycles: 2cycles
Humidity	3	40°C , 95%RH, 48h
Solder ability	15	IPC J-STD-002C-2007

Characteristic Curves

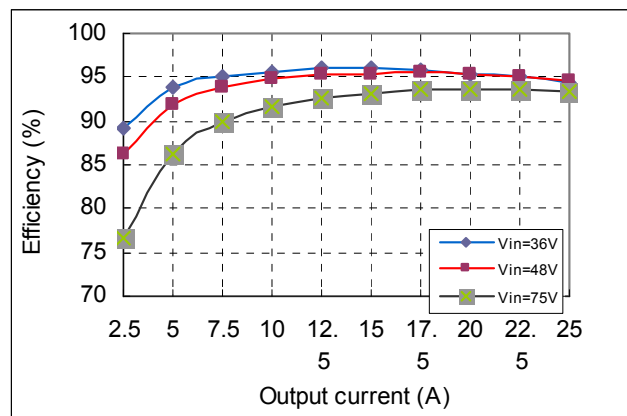

Figure 1 Efficiency vs. output current, $T_a=25^{\circ}\text{C}$, $V_o=12\text{V}$

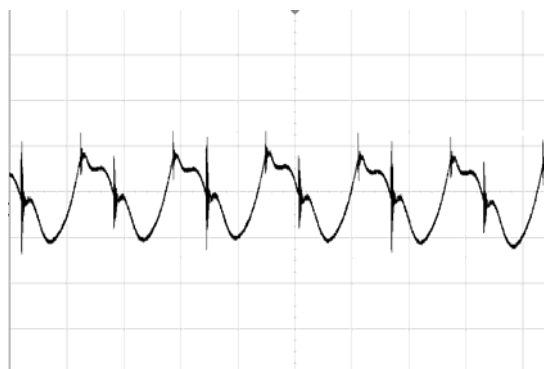

Figure 2 Output ripple & noise (2 $\mu\text{s}/\text{div}$, 20mV/div), see Figure 14 for test configuration

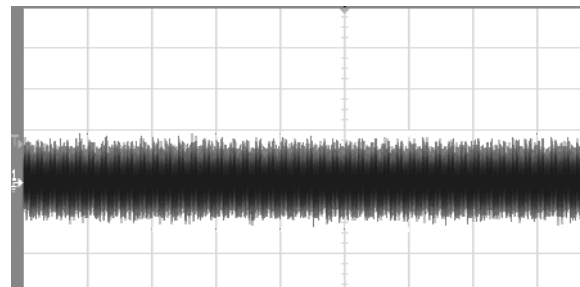

Figure 3 Input reflected ripple current (100ms/div, 10mA/div), see Figure 14 for test configuration

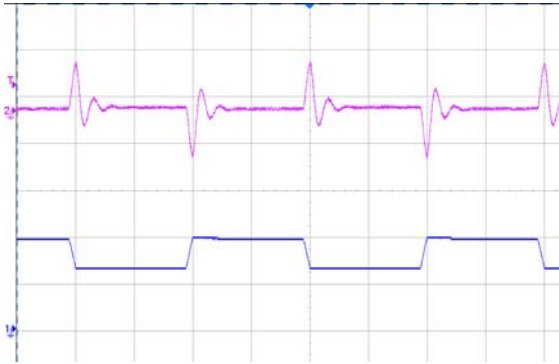

Figure 4 Dynamic response for 25% load step (50% ~ 75% ~ 50%) and 0.1A/μs slew rate, (2ms/div), see Figure 10 for test configuration; CH2-output voltage (200mV/div); CH1-output current (10A/div)



Figure 5 Dynamic response for 25% load step (50% ~ 75% ~ 50%) and 1A/μs slew rate, (2ms/div), see Figure 10 for test configuration; CH2-output voltage (200mV/div); CH1-output current (10A/div)

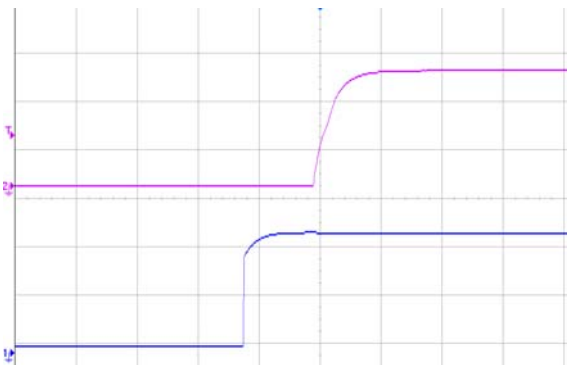

Figure 6 Output voltage startup by power on, (100ms/div), see Figure 10 for test configuration; CH2-output voltage (5V/div); CH1-input voltage (20V/div)



Figure 7 Output voltage shut down by power off, (50ms/div), see Figure 10 for test configuration; CH2-output voltage (5V/div); CH1-input voltage (20V/div)

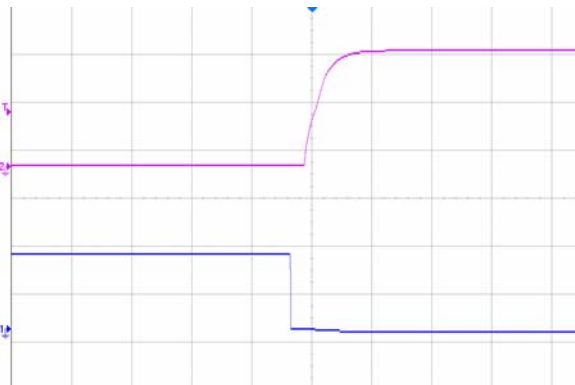

Figure 8 Output voltage startup by remote ON, (100ms/div), see Figure 10 for test configuration; CH2-output voltage (5V/div); CH1-remote ON (2V/div)

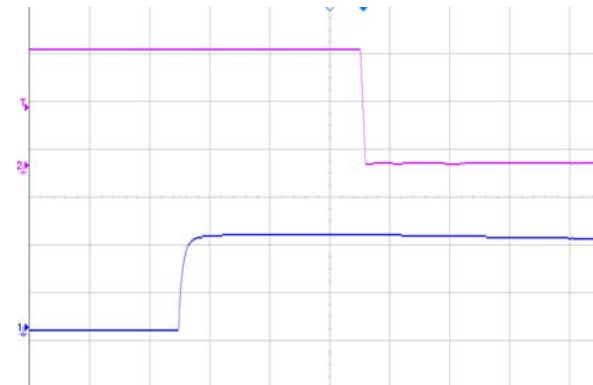

Figure 9 Output voltage shutdown by remote OFF, (5ms/div), see Figure 10 for test configuration; CH2-output voltage (5V/div); CH1-remote OFF voltage (2V/div)

Application Note

Typical Application

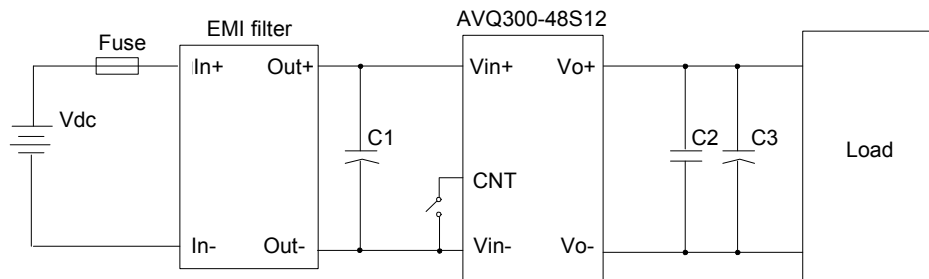

Figure 10 Typical application

C1: 100 μ F/100V electrolytic capacitor, P/N: UPM2A101MHD (Nichicon) or equivalent caps

C2: 1 μ F/100V X7R ceramic capacitor, P/N: C3225X7R2A105KT0L0U (TDK) or equivalent caps

C3: 1000 μ F electrolytic capacitor, P/N: UPM1E102MHP (Nichicon) or equivalent caps

Note: The converter cannot be used in parallel mode directly!

Fuse: External fast blow fuse with a rating of 15A. The recommended fuse model is 0324020 MXP from LITTLEFUSE.

Remote ON/OFF

The converter is equipped with a primary ON/OFF pin used to remotely turn the converter on or off via a system signal. Two CNT logic options are available. For the positive logic model a system logic low signal will turn the converter off. For the negative logic model a system logic high signal will turn the converter off. For negative logic models where no control signal will be used the ON/OFF pin should be connected directly to $-V_{in}$ to ensure proper operation. For positive logic models where no control signal will be used the ON/OFF pin should be left unconnected.

The following figure shows a few simple CNT circuits.

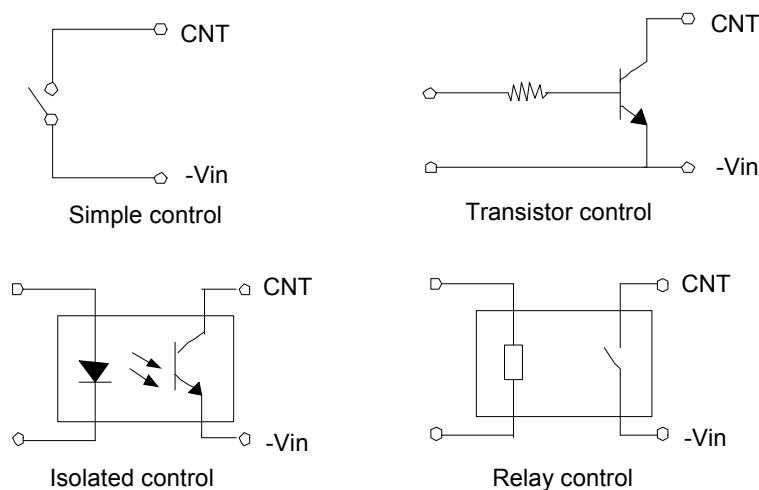

Figure 11 Remote ON/OFF internal diagram

Trim Characteristics

Connecting an external resistor between Trim pin and V_{o-} pin will decrease the output voltage. While connecting it between Trim and V_{o+} will increase the output voltage. The following equations determine the external resistance to obtain the trimmed output voltage.

$$R_{\text{trim-down}} = \left(\frac{511}{\Delta\%} - 10.22 \right) \text{k}\Omega$$

$$R_{\text{trim-up}} = \left(\frac{5.11V_{\text{nominal}}(100 + \Delta\%)}{1.225\Delta\%} - \frac{511}{\Delta\%} - 10.22 \right) \text{k}\Omega$$

$$\Delta\% = \left| \frac{V_{\text{nominal}} - V_{\text{desired}}}{V_{\text{nominal}}} \right| \times 100$$

V_{norm} : Nominal output voltage.

When trimming up, the output current should be decreased accordingly so as not to exceed the maximum output power and the minimum input voltage should be increased.

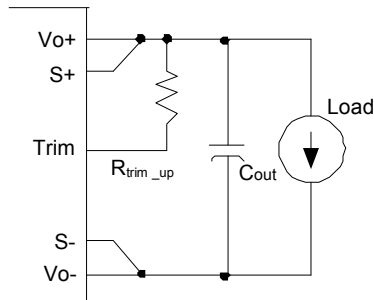

Figure 12 Trim up

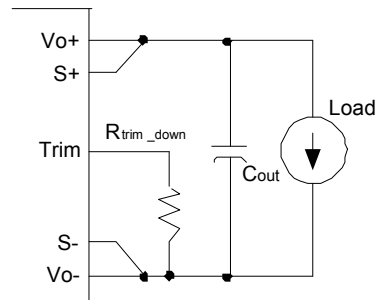

Figure 13 Trim down

Sense Characteristics

If the load is far from the unit, connect S+ and S- to the terminal of the load respectively to compensate the voltage drop on the transmission line. See Figure 10.

If the sense compensate function is not necessary, connect S+ to V_{o+} and S- to V_{o-} directly.

Input Ripple & Inrush Current And Output Ripple & Noise Test Configuration

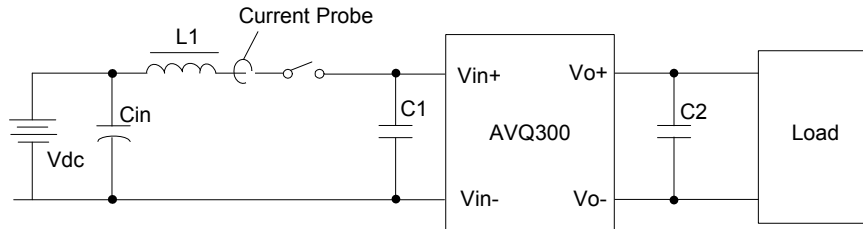

Figure 14 Input ripple & inrush current, ripple & noise test configuration

Vdc: DC power supply

L1: 12μH

Cin: 220μF/100V typical

C1: input electrolytic capacitor, according to the same type as C1 in Figure 10

C2: output electrolytic capacitor, according to the same type as C3 in Figure 10

Note: Using a coaxial cable with series 50Ω resistor and 0.68μF ceramic capacitor or a ground ring of probe to test output ripple & noise is recommended.

EMC Filter Configuration

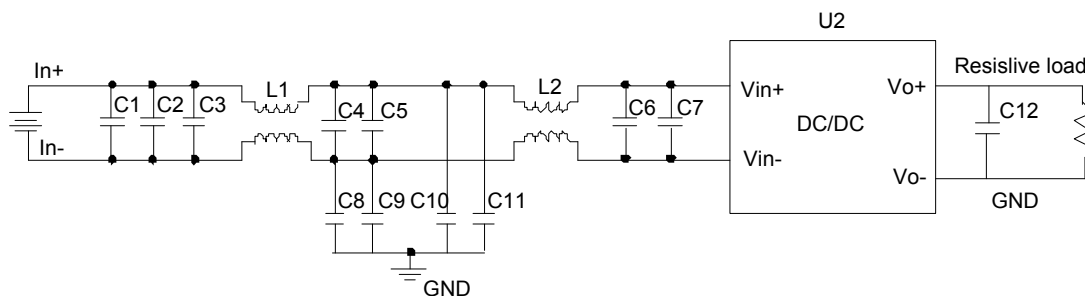

Figure 15 EMC test configuration

C1~C5: SMD ceramic capacitor -100V-1000nF-X7R-1210

C6: SMD ceramic capacitor -100V-100nF-±10%-X7R-1206

L1, L2: Common mode inductor - single phase -473μH-±25%-14A magnetic ring 1*25.4*12.7mm - working temperature range includes module temperature rise. Temperature rise at rated current: 55°C max

C8~C11: High-voltage CHIP ceramic capacitor. Capacitance: 0.1U/630V/X7R. Size: 2220. Capable of withstanding 1kV voltage

C7: Input electrolytic capacitor, according to the same type as C1 in Figure 10

C12: Output electrolytic capacitor, according to the same type as C3 in Figure 10

U2: Module to test, AVQ300-48S12B

PE: Connected to output (baseplate)

Thermal Considerations

The converter is designed to operate in different thermal environments and sufficient cooling must be provided.

Proper cooling of the DC-DC converter can be verified by measuring the temperature at the test point. The temperature at this point should not exceed the max values of 100°C.

The converter can operate in an enclosed environment without forced air convection. Cooling of the converter is achieved mainly by conduction from the baseplate to a heatsink. The converter can deliver output power at 85°C ambient temperature provided the baseplate temperature is kept below the max values of 100°C.

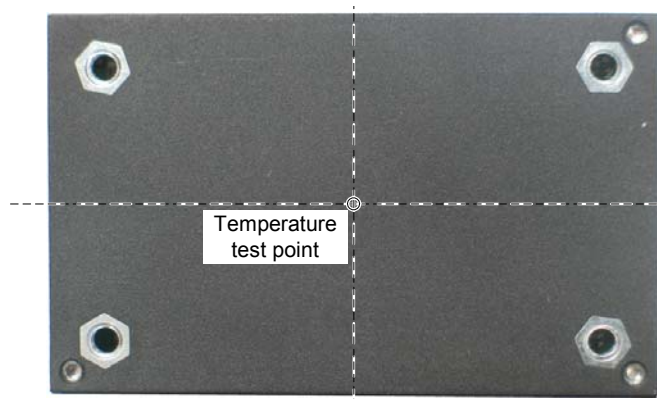

Figure 16 Temperature test point on base plate, air flowing across the converter from pin 1 to pin 3

Test point	Temperature limit
Test point	100°C

The converter can also operate with a smaller heatsink and sufficient airflow. The heatsink is shown in Figure 17.

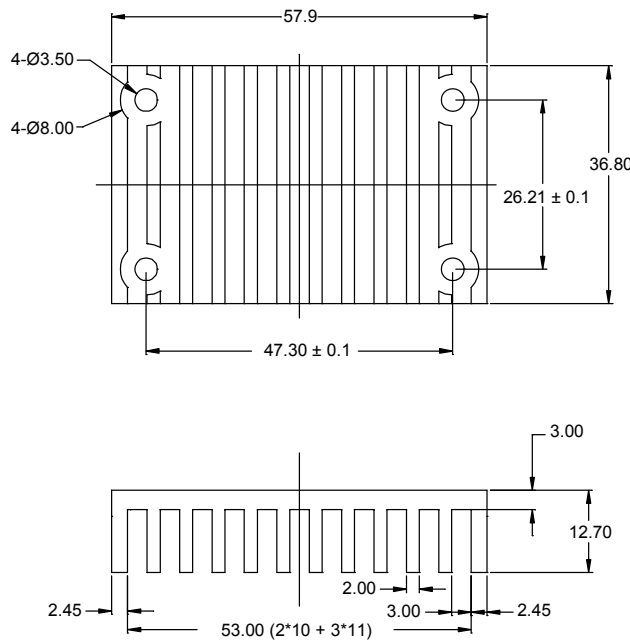

Figure 17 Heatsink

Figure 18 shows the derating output current vs. ambient air temperature at different air velocity with a heatsink, the heatsink spec is shown in Figure17. The typical test condition is shown in Figure 18.

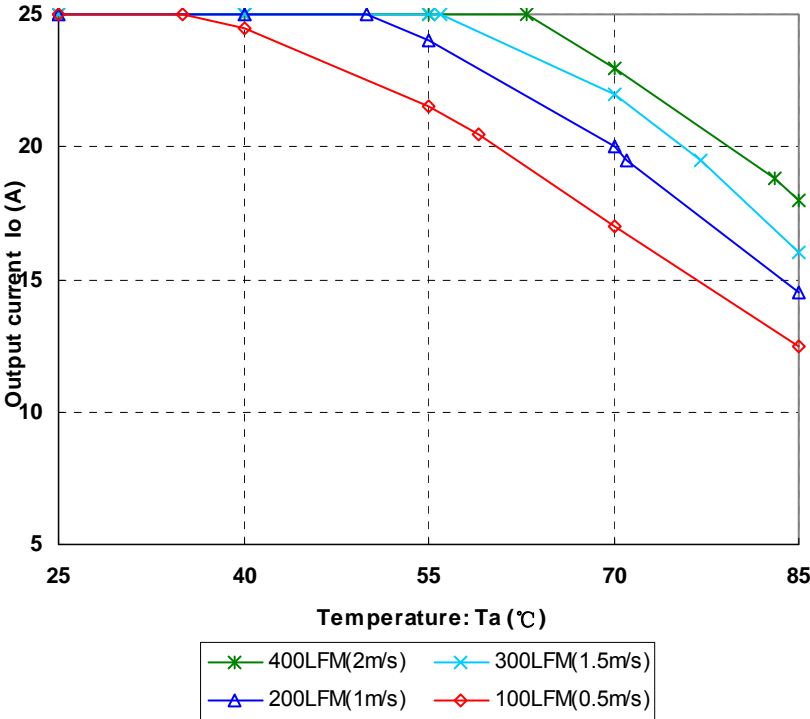
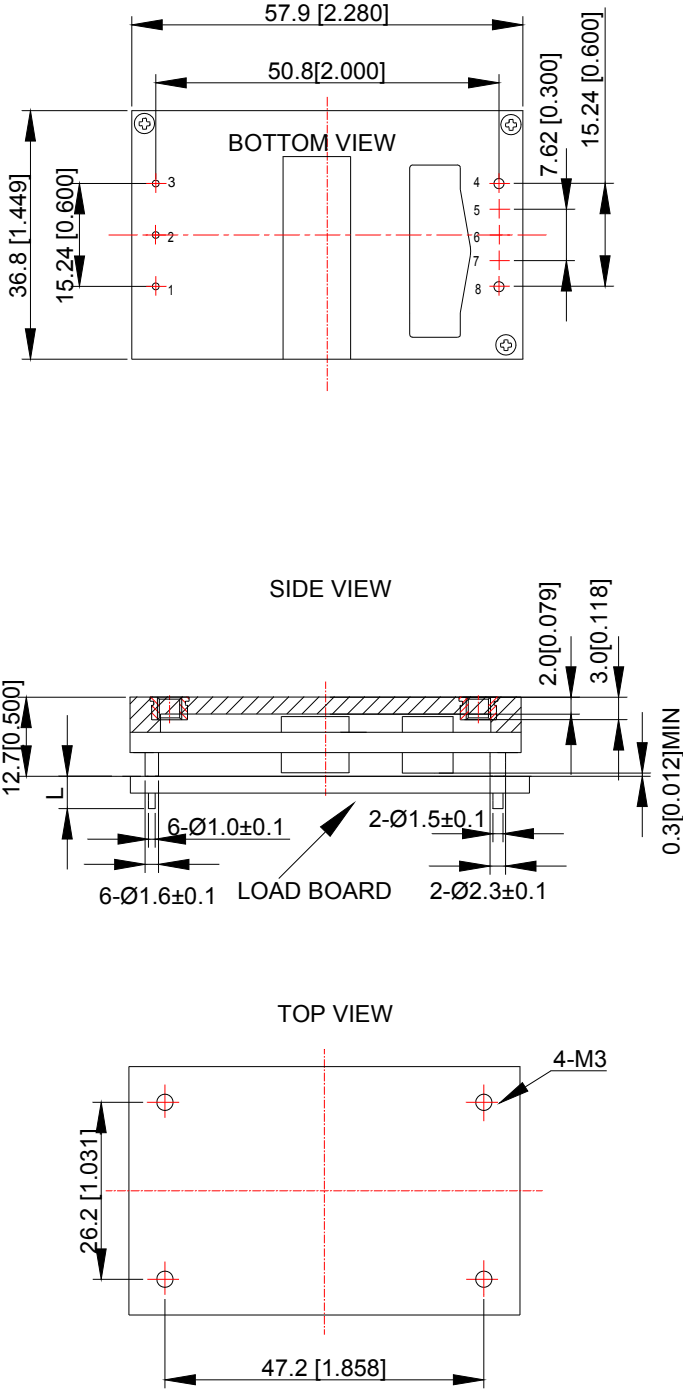

Figure 18 Output power derating, 48V_{in}, air flowing across the converter from pin 1 to pin 3

Mechanical Diagram



UNIT: mm[inch] BOTTOM VIEW: pin on upside
 TOLERANCE: X.Xmm±0.5mm[X.X in.±0.02in.]
 X.XXmm±0.25mm[X.XX in.±0.01in.]

Figure 19 Mechanical diagram

Pin length option

Device code suffix	L
-4	4.8mm±0.25mm
-6	3.8mm±0.25mm
-8	2.8mm±0.25mm
None	5.8mm±0.25mm

Pin Designations

Pin NO.	Name	Function
1	V _{in+}	Positive input terminal
2	Remote ON/OFF	ON/OFF control terminal
3	V _{in-}	Negative input terminal
4	V _{o-}	Negative output terminal
5	Sense-	Negative remote sense
6	Trim	Output voltage trim
7	Sense+	Positive remote sense
8	V _{o+}	Positive output terminal

Soldering

The product is intended for standard manual, wave soldering.

When wave soldering is used, the temperature on pins is specified to maximum 260°C for maximum 7s.

When soldering by hand, the iron temperature should be maintained at 300°C ~ 380°C and applied to the converter pins for less than 10s. Longer exposure can cause internal damage to the converter.

Cleaning of solder joint can be performed with cleaning solvent IPA or simulative.

Assembly:

The maximum length of the screw driven into heat-sink is 3.3mm.

Ordering Information

AVQ300	-	48	S	12	P	B	-	4	L
①		②	③	④	⑤	⑥		⑦	⑧

①	Model series	AVQ: high efficiency quarter brick series, 300: output power 300W
②	Input voltage	48: 36V ~ 75V input range, rated input voltage 48V
③	Output number	S: single output
④	Rated output voltage	12: 12V output
⑤	Remote ON/OFF logic	Default: negative; P: positive logic
⑥	baseplated	with baseplate
⑦	Pin length	-4: 4.8mm ± 0.25mm
⑧	RoHS status	L: RoHS, R6; Y: RoHS, R5

Model number	Description
AVQ300-48S12B-4L	4.8mm pin length; negative on/off logic; without thread inside mounting hole; R6 compliant
AVQ300-48S12PB-4L	4.8mm pin length; positive on/off logic; without thread inside mounting hole; R6 compliant
AVQ300-48S12B-4Y	4.8mm pin length; negative on/off logic; without thread inside mounting hole; R5 compliant
AVQ300-48S12PB-4Y	4.8mm pin length; positive on/off logic; without thread inside mounting hole; R5 compliant

Hazardous Substances Announcement (RoHS Of China)

Parts	Hazardous Substances					
	Pb	Hg	Cd	Cr ⁶⁺	PBB	PBDE
AVQ300-48S12B	○	○	○	○	○	○
<p>○: Means the content of the hazardous substances in all the average quality materials of the part is within the limits specified in SJ/T-11363-2006</p> <p>√: Means the content of the hazardous substances in at least one of the average quality materials of the part is outside the limits specified in SJ/T11363-2006</p> <p>Emerson Network Power Co., Ltd. has been committed to the design and manufacturing of environment-friendly products. It will reduce and eventually eliminate the hazardous substances in the products through unremitting efforts in research. However, limited by the current technical level, the following parts still contain hazardous substances due to the lack of reliable substitute or mature solution:</p> <ol style="list-style-type: none"> 1. Solders (including high-temperature solder in parts) contain plumbum. 2. Glass of electric parts contains plumbum. 3. Copper alloy of pins contains plumbum 						