

COSEL AC-DC Power Supplies DIN Rail type

KHNA series

Ordering information

KHN **A** **F** **-24**

① ② ③ ④ ⑤ ⑥

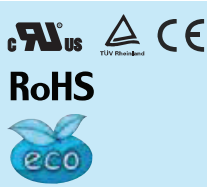

Recommended EMI/EMC Filter
KHNA120F NAC-04-472-D
KHNA240F NAC-06-472-D
KHNA480F NAC-10-472-D



High voltage pulse noise type: NAP series
Low leakage current type: NAM series
*The EMI/EMC Filter is recommended to connect with several devices.

- ① Series name
- ② Single output
- ③ Output wattage
- ④ Universal input
- ⑤ Output voltage
- ⑥ Option
- C : with Coating
- N2: Screw mounting

| MODEL | KHNA120F-24 | KHNA240F-24 | KHNA480F-24 |
|-----------------------|--------------------|--------------------|--------------------|
| MAX OUTPUT WATTAGE[W] | 120 | 240 | 480 |
| DC OUTPUT | 24V 5A (Peak 7.5A) | 24V 10A (Peak 15A) | 24V 20A (Peak 30A) |

SPECIFICATIONS

| | MODEL | KHNA120F-24 | KHNA240F-24 | KHNA480F-24 | |
|------------------------------------|--|--|---|---|---------|
| INPUT | VOLTAGE[V] | AC85 - 264 1 φ or DC120 - 370 | | | |
| | CURRENT[A] | ACIN 115V | 1.2typ | 2.3typ | 4.6typ |
| | | ACIN 230V | 0.6typ | 1.2typ | 2.3typ |
| | FREQUENCY[Hz] | 50 / 60 (47 - 63) or DC | | | |
| | EFFICIENCY[%] | ACIN 115V | 90typ | 92typ | 92typ |
| | | ACIN 230V | 92typ | 94typ | 94typ |
| | POWER FACTOR | ACIN 115V | 0.98typ | 0.98typ | 0.98typ |
| | | ACIN 230V | 0.93typ | 0.93typ | 0.93typ |
| | INRUSH CURRENT[A] | ACIN 115V | 15typ (at cold start Ta=25°C) | 20typ (more than 3 sec. to re-start) | |
| | | *1 ACIN 230V | 30typ (at cold start Ta=25°C) | 40typ (more than 3 sec. to re-start) | |
| LEAKAGE CURRENT[mA] | 0.45 / 0.75max | | | 0.75 / 1.5max | |
| | (ACIN 100V / 240V 60Hz, Io=100%, According to IEC60950-1 and DEN-AN) | | | | |
| OUTPUT | VOLTAGE[V] | 24 | 24 | 24 | |
| | CURRENT[A] | 5 | 10 | 20 | |
| | PEAK CURRENT[A] | *2 7.5 | 15 | 30 | |
| | LINE REGULATION[mV] | *3 96max | 96max (Io=30-100%) *10 | | |
| | LOAD REGULATION[mV] | *3 150max *4 | 150max (Io=30-100%) *10 | | |
| | RIPPLE[mVp-p] | *5 0 to +70°C | 120max | 120max | 120max |
| | | -25 - 0°C | 240max | 240max | 240max |
| | | Io=0 - 30% | 240max *4 | 500max | 500max |
| | RIPPLE NOISE[mVp-p] | *5 0 to +70°C | 150max | 150max | 150max |
| | | -25 - 0°C | 300max | 300max | 300max |
| | | Io=0 - 30% | 300max *4 | 600max | 600max |
| | TEMPERATURE REGULATION[mV] | 0 to +70°C | 240max *4 | 240max | 240max |
| | | -25 to +70°C | 360max *4 | 360max | 360max |
| | DRIFT[mV] | *6 96max | 96max | | |
| | START-UP TIME[ms] | 750max (ACIN 115V, Io=100%) | 750max (ACIN 115V, Io=100%) | | |
| | HOLD-UP TIME[ms] | 20typ (ACIN 115V, Io=100%) | 20typ (ACIN 115V, Io=100%) | | |
| OUTPUT VOLTAGE ADJUSTMENT RANGE[V] | 22.5 to 28.5 | 22.5 to 26.4 | | | |
| OUTPUT VOLTAGE SETTING[V] | 24.0 ± 1.0% | 24.0 ± 1.0% | | | |
| PROTECTION CIRCUIT AND OTHERS | OVERCURRENT PROTECTION | Works over 101% of peak current and recovers automatically | | | |
| | OVERVOLTAGE PROTECTION[V] | 30.0 to 36.0 | | | |
| | DC_OK LAMP | LED (Green) | | | |
| | ALARM LAMP | LED (Red) | | | |
| | DC_OK CONTACT | - | | | |
| ISOLATION | INPUT-OUTPUT | AC3,000V 1minute, Cutoff current = 10mA, DC500V 50MΩ min (At Room Temperature) | | | |
| | INPUT-PE | AC2,000V 1minute, Cutoff current = 10mA, DC500V 50MΩ min (At Room Temperature) | | | |
| | OUTPUT-PE | AC500V 1minute, Cutoff current = 100mA, DC500V 50MΩ min (At Room Temperature) | | | |
| | OUTPUT-RC | AC500V 1minute, Cutoff current = 100mA, DC500V 50MΩ min (At Room Temperature) | | | |
| ENVIRONMENT | OPERATING TEMP., HUMID. AND ALTITUDE | -25 to +70°C (Required to Derating), 20 - 90%RH (Non condensing) | | | |
| | STORAGE TEMP., HUMID. AND ALTITUDE | -40 to +85°C, 20 - 90%RH (Non condensing) | | | |
| | VIBRATION | *9 10 - 55Hz, 19.6m/s ² (2G), 3minutes period, 60 minutes along Z axis (Non operating, mounted on DIN Rail) | | | |
| SAFETY AND NOISE REGULATIONS | IMPACT | 196.1m/s ² (20G), 11ms, once each X, Y and Z axis (Packing state) | | | |
| | AGENCY APPROVALS (At only AC input) | UL60950-1, C-UL (CSA60950-1), EN60950-1, EN50178, UL508, ANSI / ISA12.12.01 Complies with DEN-AN | | | |
| | CONDUCTED NOISE | Complies with FCC-B, VCCI-B, CISPR22-B, EN55011-B, EN55022-B | | | |
| OTHERS | HARMONIC ATTENUATOR | Complies with IEC61000-3-2 (Class A) *7 | | | |
| | CASE SIZE | *8 37 × 124 × 117mm (W × H × D) [1.46 × 4.88 × 4.61 inches] | 50 × 124 × 117mm (W × H × D) [1.97 × 4.88 × 4.61 inches] | 70 × 124 × 117mm (W × H × D) [2.76 × 4.88 × 4.61 inches] | |
| | WEIGHT | 580g max | 900g max | 1,200g max | |
| | COOLING METHOD | Convection / Forced air | | | |

*1 The value is primary surge. The current of input surge to a built-in EMI/EMC Filter (0.2ms or less) is excluded.
*2 Refer to 3. instruction manual.
*3 Please contact us about dynamic load and input response.
*4 The output voltage is below 23.5V, the value is equal to three times of the specification.
*5 This is the value that measured on measuring board with capacitor of 22μF and 0.1μF at 150mm from output terminal.
*6 Measured by 20MHz oscilloscope or Ripple-Noise meter (Equivalent to KEISOKU-GIKEN: RM103). Please refer to the instruction manual 2.7.
*7 Drift is the change in DC output for an eight hour period after a half-hour warm-up at 25°C, with the input voltage held constant at the rated input/output.
*8 Please contact us about another class.
*9 Case size contains neither the unbr.
*10 Only as standard mounting orientation (A). Refer to the instruction manual 5.1. If install other than standard mounting orientation (A), please fix the power supply for withstand the vibration and impact.
*11 Burst operation at 30% load or less.
*12 Output derating is required. Please refer to the instruction manual 5.2.
* Please contact us about DC input voltage.
* To meet the specifications. Do not operate over-loaded condition.
* A sound may occur from power supply at light or peak loading.

Specifications are subject to change without notice. It is responsibility of each customer to thoroughly test each product and part number under their unique parameters and environments to ensure a product will work properly and reliably.

Click below for more details, to buy on-line or request volume pricing:
<http://power.sager.com/cosel-KHNA480F-power-supply.html>

(866) 588-1750
power@sager.com
<http://power.sager.com>

External view

■ KHNA120F

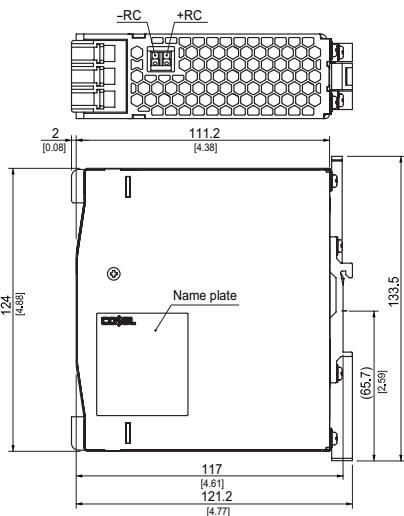
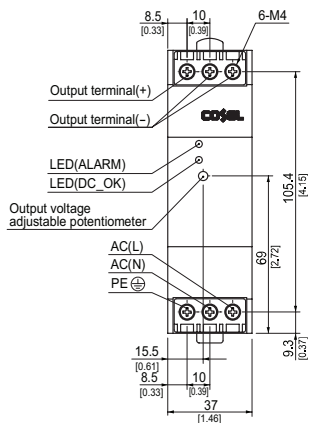

- ※ Tolerance : ±1 [±0.04]
- ※ Weight : 580g max
- ※ PCB Material/thickness : FR-4 / 1.6mm [0.06]
- ※ Chassis material : Aluminum
- ※ Case material : Stainless steel
- ※ DIN rail attachment material : Aluminum, Nylon
- ※ Dimensions in mm, [] = inches
- ※ Screw tightening torque : 1.6N · m max

■ KHNA240F

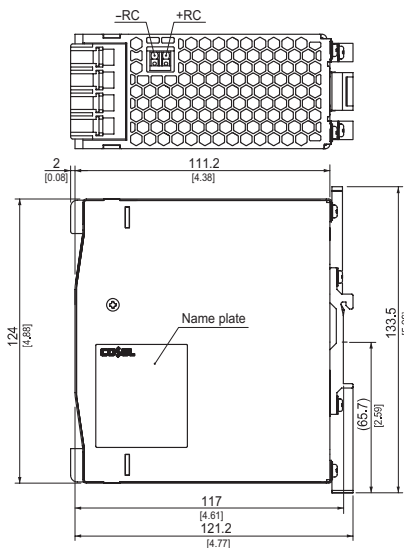
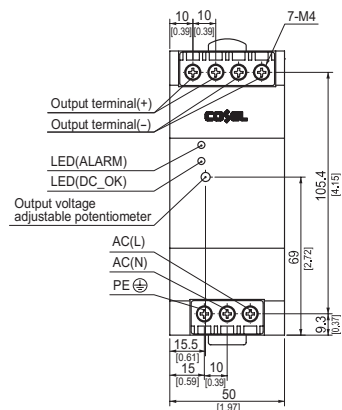

- ※ Tolerance : ±1 [±0.04]
- ※ Weight : 900g max
- ※ PCB Material/thickness : FR-4 / 1.6mm [0.06]
- ※ Chassis material : Aluminum
- ※ Case material : Stainless steel
- ※ DIN rail attachment material : Aluminum, Nylon
- ※ Dimensions in mm, [] = inches
- ※ Screw tightening torque : 1.6N · m max

■ KHNA480F

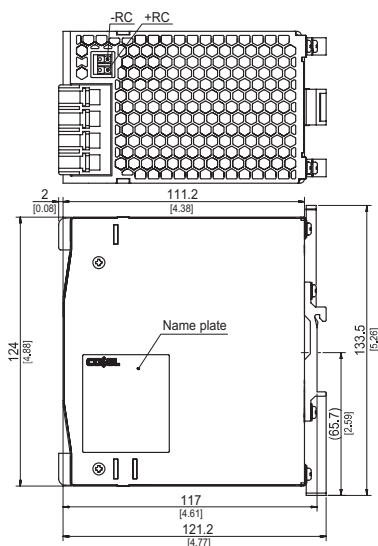
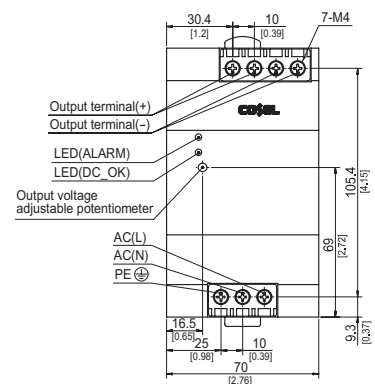

- ※ Tolerance : ±1 [±0.04]
- ※ Weight : 1,200g max
- ※ PCB Material/thickness : FR-4 / 1.6mm [0.06]
- ※ Chassis material : Aluminum
- ※ Case material : Stainless steel
- ※ DIN rail attachment material : Aluminum, Nylon
- ※ Dimensions in mm, [] = inches
- ※ Screw tightening torque : 1.6N · m max

Specifications are subject to change without notice. It is responsibility of each customer to thoroughly test each product and part number under their unique parameters and environments to ensure a product will work properly and reliably.

Click below for more details, to buy on-line or request volume pricing:
<http://power.sager.com/cosel-KHNA480F-power-supply.html>

(866) 588-1750
power@sager.com
<http://power.sager.com>