

THIS DRAWING IS UNPUBLISHED. RELEASED FOR PUBLICATION
 © COPYRIGHT BY TYCO ELECTRONICS CORPORATION. ALL RIGHTS RESERVED.

LOC		DIST		REVISIONS			
P	LTR	DESCRIPTION		DATE	DWN	APVD	
E	B	D	ECR-06-001573	23-01-06	C.B.	J.C.	

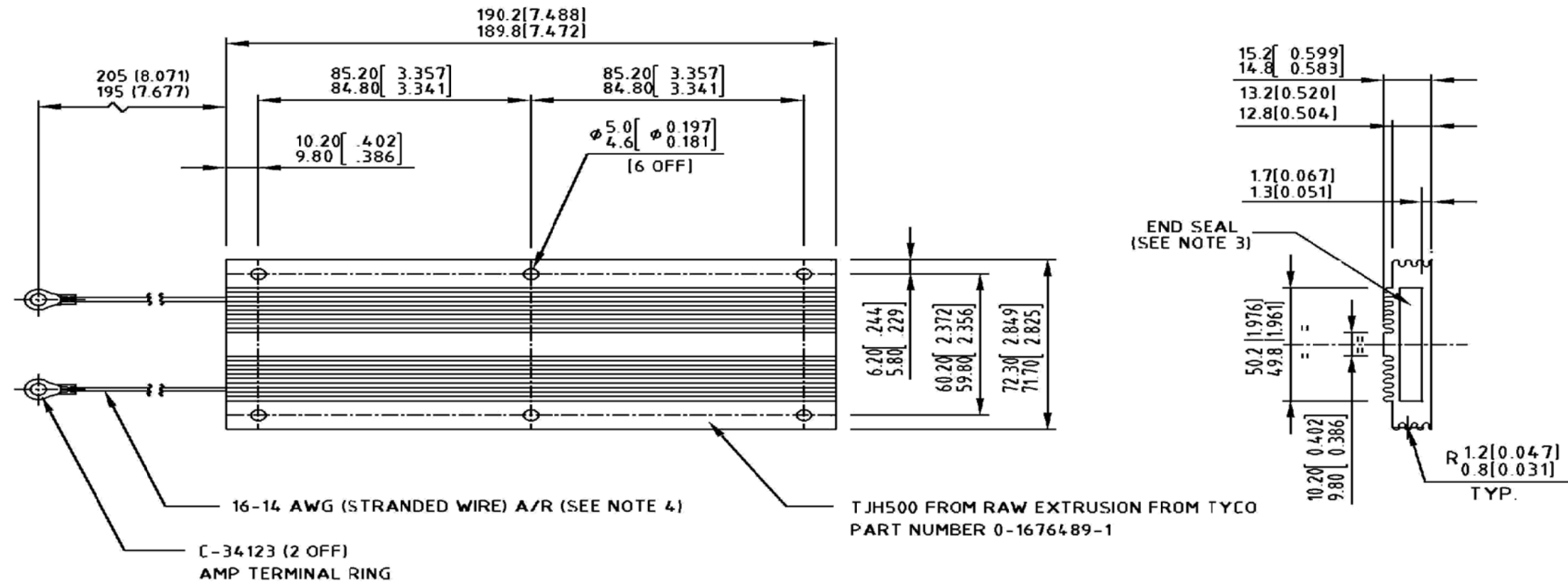

SPECIFICATION TABLE

TYCO PART No. :	0-1630954-1
POWER RATING	400W
POWER RATING AT 400W FOR A MAXIMUM CASE SURFACE TEMP RISE OF 150 C	
RESISTANCE	10 ohms
STANDARD TOLERANCE	+/-10%
INSULATION VOLTAGE ACrms	2.5KV
INSULATION RESISTANCE GOhm	>90
SERIES INDUCTANCE uH	5.4
OPERATING TEMPERATURE RANGE	-60 C TO +150 C
HEAT SINK RATING	0.38 C/W

- NOTES :**
1. FINISH : EXTRUSION TO BE CLEAN AND DEBURRED
EXTRUSION TO BE ANODISED NATURAL CLEAR 9um +/- 1um
 2. INTERNAL FILLER FORTAFIX CEMENT.
 3. END SEAL : BOTH ENDS TO BE SEALED WITH DOW CORNING 736 SEALANT
 4. WIRE : 32/0.2mm SILICONE COATED NICKEL COATED COPPER WIRE

MANUFACTURER : TYCO
 ORDERING PROCEDURE :
 QUOTE GOODRICH REFERENCE NUMBER, CURRENT ISSUE OF DRAWING
 86603343, CURRENT ISSUE OF DRAWING

THIS ITEM IS FOR AEROSPACE APPLICATION AND IS SUBJECT TO TYPE APPROVAL TESTING. NO CHANGE TO ITEMS SUPPLIED TO THIS DESIGN STANDARD IS PERMITTED EXCEPT AS AUTHORISED BY "GOODRICH CONTROL SYSTEMS LIMITED - ENGINE CONTROL SYSTEMS". ITEMS MAY BE PURCHASED EITHER FROM THE MANUFACTURER OR THEIR APPROVED AGENTS, BUT IN ALL CASES ALTERNATIVE MANUFACTURERS TO THOSE LISTED UNDER THE GOODRICH CONTROL SYSTEMS LIMITED - ENGINE CONTROL SYSTEMS PART No. ARE NOT PERMITTED.

Schedule	Tyco Part No.	Description	Customer Part No.
	0-1676126-1	TJH750 BRAKE RESISTOR (6 Ohms) 730 & 400mm Leads	090912-01

THIS DRAWING IS A CONTROLLED DOCUMENT.		DWN	Chris Bolle	05-09-03	tyco Electronics	Tyco Electronics Corporation Dorcan, Swindon, GB	
DIMENSIONS: MM		CHK	Chris Bolle	05-09-03		NAME TJH750 BRAKE RESISTOR	
TOLERANCES UNLESS OTHERWISE SPECIFIED:		APVD	Jonathan Catchpole	05-09-03	PRODUCT SPEC		
0 PLC ± -		APPLICATION SPEC		SIZE			
1 PLC ± 0.2		WEIGHT		A3		CAGE CODE	00779
2 PLC ± -		CUSTOMER DRAWING		DRAWING NO		C-1676126	
3 PLC ± -		SCALE		1:1		SHEET	
4 PLC ± -		RESTRICTED TO		1		OF	
ANGLES ± -		REV		D		1	
FINISH		REV		D		1	