

Proximity Sensor

E2EQ

A Series of Spatter-preventing Proximity Sensors with a Teflon-coated Metal Housing

- Teflon*-coated metal housing endures high tightening torque.
- Pre-wired and plug-in models are available.
- Long sensing-distance type included in series.

*Teflon is a registered trademark of the Dupont Company and the Mitsui Dupont Chemical Company for their fluoride resin.



Ordering Information

■ Standard Type Pre-wired Models

Shield	Size	Sensing distance	Output configuration	Models
Shielded 	M12	3 mm	NO	E2EQ-X3D1
	M18	7 mm		E2EQ-X7D1
	M30	10 mm		E2EQ-X10D1

Plug-in Models

Shield	Size	Sensing distance	Output configuration	Models
Shielded 	M12	3 mm	NO	E2EQ-X3D1-M1GJ
	M18	7 mm		E2EQ-X7D1-M1GJ
	M30	10 mm		E2EQ-X10D1-M1GJ

■ Long Sensing-distance Type Pre-wired Models



Shield	Size	Sensing distance	Output configuration	Models
Shielded 	M12	4 mm	NO	E2EQ-X4X1
	M18	8 mm		E2EQ-X8X1
	M30	15 mm		E2EQ-X15X1

Plug-in Models

Shield	Size	Sensing distance	Output configuration	Models
Shielded 	M12	4 mm	NO	E2EQ-X4X1-M1J
	M18	8 mm		E2EQ-X8X1-M1J
	M30	15 mm		E2EQ-X15X1-M1J

■ Accessories (Sold Separately)

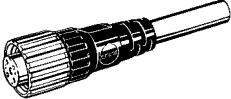
Sensor I/O Connectors

Appearance	Cord length	Applicable Proximity Sensor	Models
	2 m	E2EQ-X□D1-M1GJ	XS2F-D421-DA0-A
		E2EQ-X□X1-M1J	XS2F-D421-DD0
	5 m	E2EQ-X□D1-M1GJ	XS2F-D421-GA0-A
		E2EQ-X□X1-M1J	XS2F-D421-GD0
	2 m	E2EQ-X□D1-M1GJ	XS2F-D422-DA0-A
		E2EQ-X□X1-M1J	XS2F-D422-DD0
	5 m	E2EQ-X□D1-M1GJ	XS2F-D422-GA0-A
		E2EQ-X□X1-M1J	XS2F-D422-GD0

Specifications

■ Ratings/Characteristics

Standard Type

Item		E2EQ-X3D1 E2EQ-X3D1-M1GJ	E2EQ-X7D1 E2EQ-X7D1-M1GJ	E2EQ-X10D1 E2EQ-X10D1-M1GJ
Supply voltage (operating voltage range)		12 to 24 VDC, ripple (p-p): 10% max., (10 to 30 VDC)		
Leakage current		0.8 mA max.		
Sensing object		Ferrous metals (refer to <i>Engineering Data</i> for non-ferrous metals)		
Sensing distance		3 mm ±10%	7 mm ±10%	10 mm ±10%
Setting distance (standard object)		0 to 2.4 mm (Mild steel, 12 x 12 x 1 mm)	0 to 5.6 mm (Mild steel, 18 x 18 x 1 mm)	0 to 8.0 mm (Mild steel, 30 x 30 x 1 mm)
Differential travel		10% max. of sensing distance		
Response frequency (see note 1)		1.0 kHz	0.5 kHz	0.4 kHz
Operating status (with sensing object approaching)		Load ON		
Control Output	Switching capacity	3 to 100 mA		
	Residual voltage	3 V max. (under load current of 100 mA with cable length of 2 m)		
Voltage influence		±2.5% max. of sensing distance in rated voltage range ±15%		
Circuit protection		Surge absorber, short-circuit protection		
Indicators		Operation indicator (red LED), operation set indicator (green LED)		
Ambient temperature		Operating: -25 to 70°C (with no icing)		
Ambient humidity		Operating: 35% to 95%		
Temperature influence		±10% max. of sensing distance at 23°C in the temperature range of -25 and 70°C		
Insulation resistance		50 MΩ min. (at 500 VDC) between current carry parts and case		
Dielectric strength		1,000 VAC for 1 min between current carry parts and case		
Vibration resistance		10 to 55 Hz, 1.5-mm double amplitude for 2 hrs each in X, Y, and Z directions		
Shock resistance		1,000 m/s ² (approx. 100G) for 10 times each in X, Y, and Z directions		
Enclosure rating		IEC60529 IP67		
Weight (pre-wired models)		Approx. 120 g	Approx. 160 g	Approx. 220 g
Material	Case	Teflon resin coating (base: brass) (see note 2)		
	Sensing surface	Teflon resin (see note 2)		

- Note:**
- The response frequencies for DC switching are average values measured on condition that the distance between each sensing object is twice as large as the size of the standard object and the sensing distance set is half of the maximum sensing distance.
 - Teflon is a registered trademark of the Dupont Company and the Mitsui Dupont Chemical Company for their fluoride resin.

Long Sensing-distance Type

Item		E2EQ-X4X1 E2EQ-X4X1-M1J	E2EQ-X8X1 E2EQ-X8X1-M1J	E2EQ-X15X1 E2EQ-X15X1-M1J
Supply voltage (operating voltage range)		12 to 24 VDC, ripple (p-p): 10% max., (10 to 30 VDC)		
Leakage current		0.8 mA max.		
Sensing object		Ferrous metals (refer to <i>Engineering Data</i> for non-ferrous metals)		
Sensing distance		4 mm ±10%	8 mm ±10%	15 mm ±10%
Setting distance (standard object)		0 to 3.2 mm (Mild steel, 12 x 12 x 1 mm)	0 to 6.4 mm (Mild steel, 18 x 18 x 1 mm)	0 to 12 mm (Mild steel, 30 x 30 x 1 mm)
Differential travel		15% max. of sensing distance		
Response frequency (see note 1)		1.0 kHz	0.5 kHz	0.25 kHz
Operating status (with sensing object approaching)		Load ON		
Control Output	Switching capacity	3 to 100 mA		
	Residual voltage	5 V max. (under load current of 100 mA with cable length of 2 m)		
Voltage influence		±1% max. of sensing distance in rated voltage range of ±15%		
Circuit protection		Surge absorber, short-circuit protection		
Indicators		Operation indicator (red LED), operation set indicator (green LED)		
Ambient temperature		Operating: -25°C to 70°C (with no icing)		
Ambient humidity		Operating: 35% to 95%		
Temperature influence		±10% max. of sensing distance at 23°C in the temperature range of -25 and 70°C		
Insulation resistance		50 MΩ min. (at 500 VDC) between current carry parts and case		
Dielectric strength		1,000 VAC for 1 min between current carry parts and case		
Vibration resistance		10 to 55 Hz, 1.5-mm double amplitude for 2 hrs each in X, Y, and Z directions		
Shock resistance		1,000 m/s ² (approx. 100G) for 10 times each in X, Y, and Z directions		
Enclosure rating		IEC60529 IP67		
Weight (pre-wired models)		Approx. 120 g	Approx. 160 g	Approx. 220 g
Material	Case	Teflon resin coating (base: brass) (see note 2)		
	Sensing surface	Teflon resin (see note 2)		

- Note:**
1. The response frequencies for DC switching are average values measured on condition that the distance between each sensing object is twice as large as the size of the standard object and the sensing distance set is half of the maximum sensing distance.
 2. Teflon is a registered trademark of the Dupont Company and the Mitsui Dupont Chemical Company for their fluoride resin.

Engineering Data

Operating Range (Typical)

E2EQ-X□D

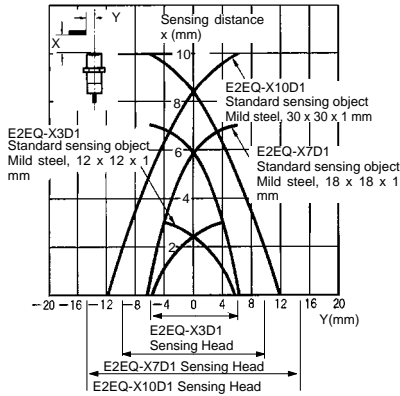

Residual Output Voltage Characteristics (Typical)

E2EQ-X□D1

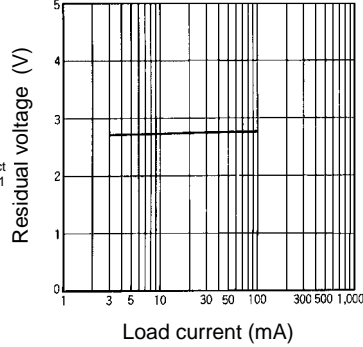

Leakage Current Characteristics (Typical)

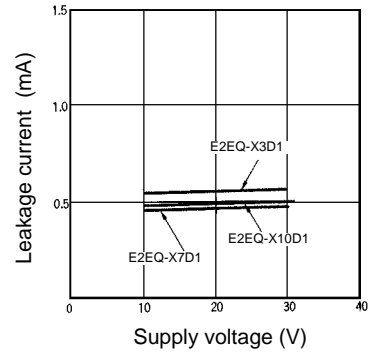

E2EQ-X□X

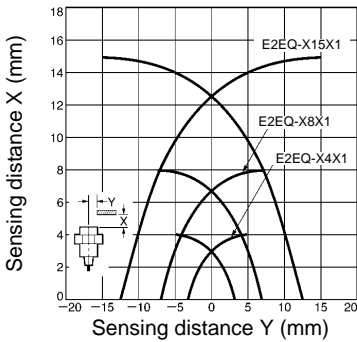

E2EQ-X□X

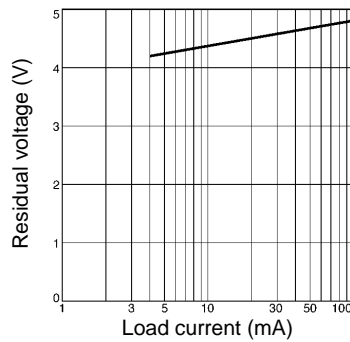

Influence of Sensing Object Size and Materials

E2EQ-X3D1 (-M1GJ)

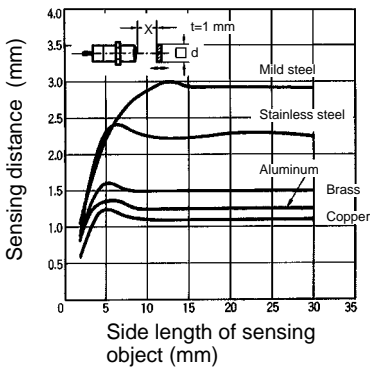

E2EQ-X7D1 (-M1GJ)

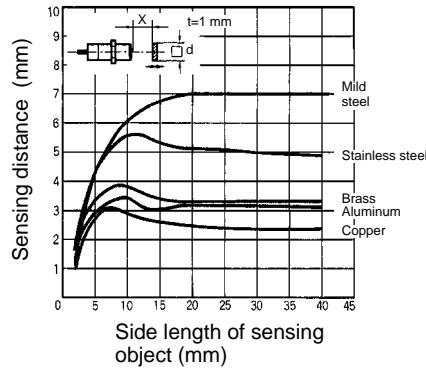

E2EQ-X10D1 (-M1GJ)

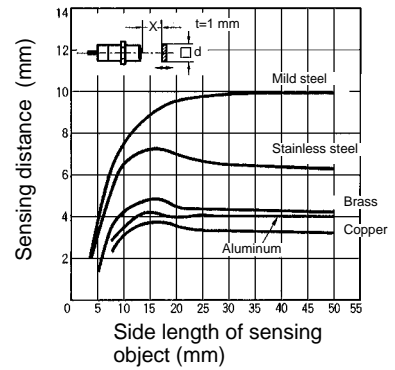

E2EQ-X4X1 (-M1J)

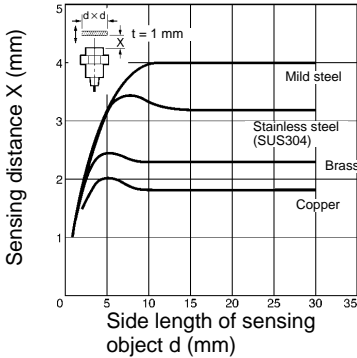

E2EQ-X8X1 (-M1J)

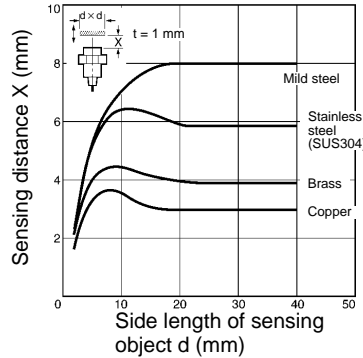

E2EQ-X15X1 (-M1J)

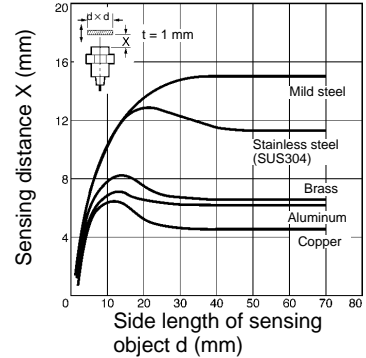

Operation

Output Circuit Diagram Standard Type

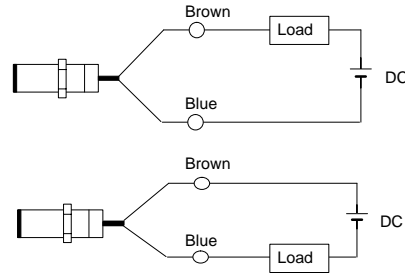
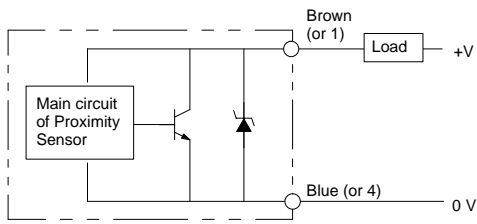

Note: It is possible to connect the load in two ways as shown in the above diagrams.

Long Sensing-distance Type

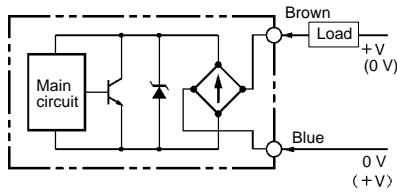

- Note:**
1. The load can be connected to either the +V or the 0-V line.
 2. Since there is no polarity, there is no need to pay attention to the brown or blue polarity.

Wiring Standard Type E2EQ-X□D1-M1GJ

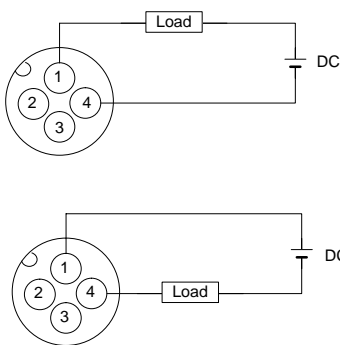

Note: Terminals 2 and 3 are not used.

Long Sensing-distance Type E2EQ-X□X-M1J

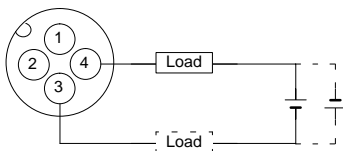

Operating Chart

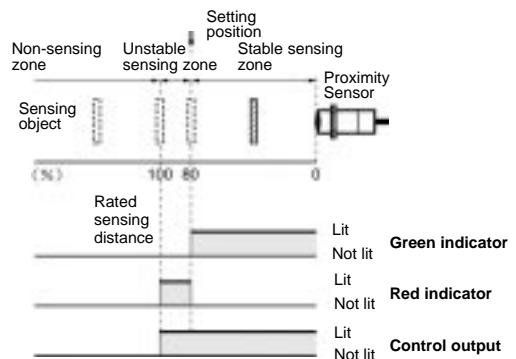
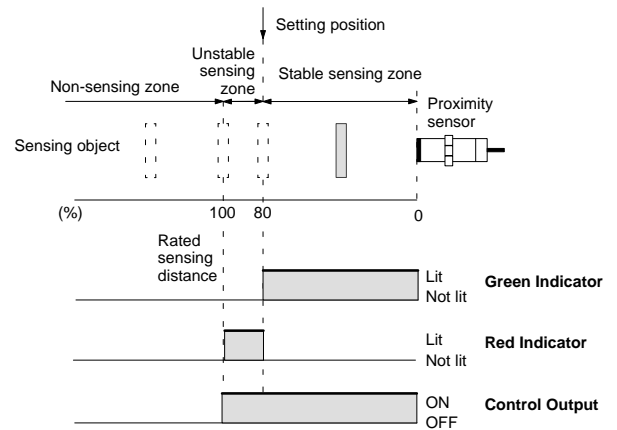

Dimensions

■ Standard Type

Note: All units are in millimeters unless otherwise indicated.

E2EQ-X3D1

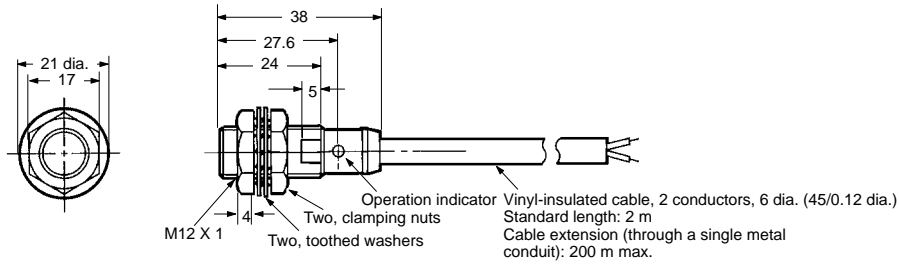

E2EQ-X7D1

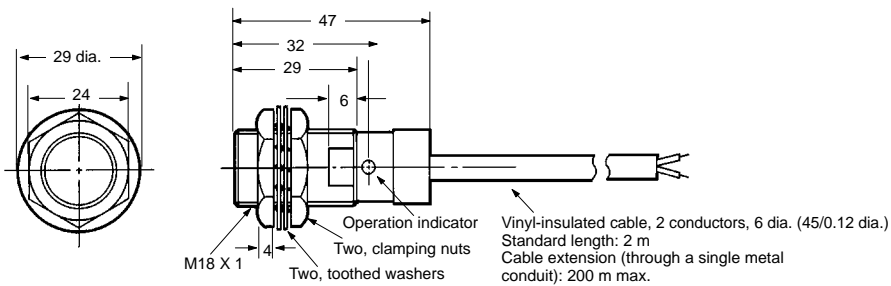

E2EQ-X10D1

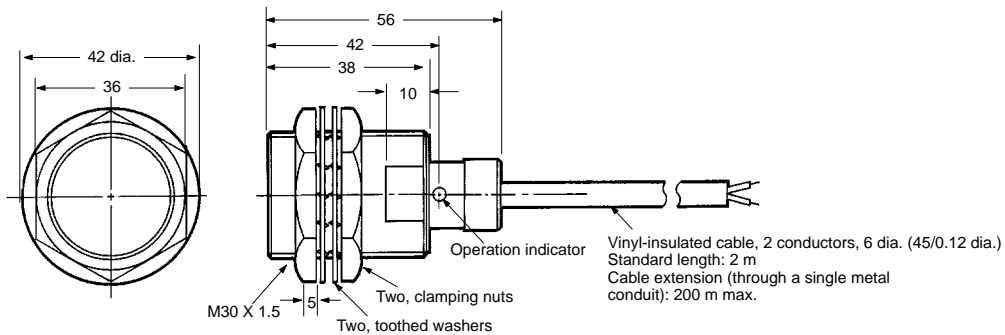

E2EQ-X3D1-M1GJ

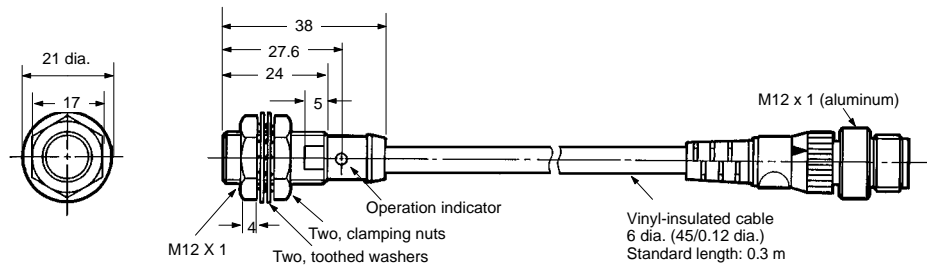

E2EQ-X7D1-M1GJ

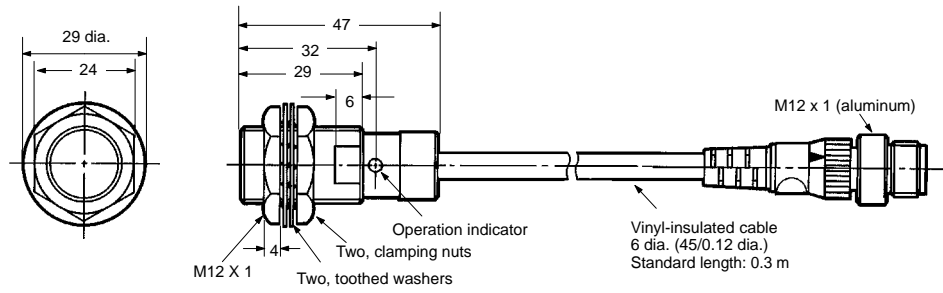

E2EQ-X10D1-M1GJ

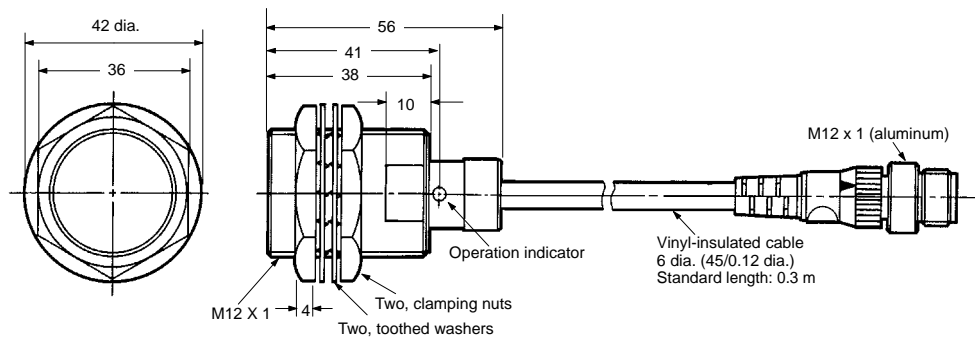

■ Long Sensing-distance Type

E2EQ-X4X1

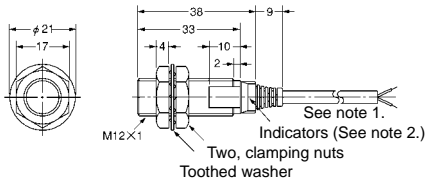

- Note:**
1. Vinyl-insulated round cable (flame-resistant), 4 dia. 2/3 conductors (conducting cross-sectional area: 0.3 mm²; insulator diameter: 1.3 mm) Standard length: 2 m Cable extension (through a single metal conduit): 200 m max.
 2. Operation indicator (red) and setting indicator (green).

E2EQ-X8X1

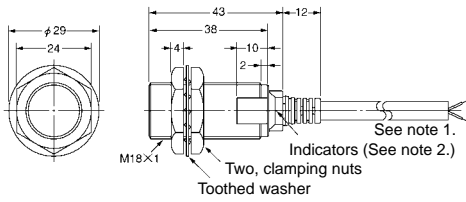

- Note:**
1. Vinyl-insulated round cable (flame-resistant), 6 dia. 2/3 conductors (conducting cross-sectional area: 0.5 mm²; insulator diameter: 1.9 mm) Standard length: 2 m Cable extension (through a single metal conduit): 200 m max.
 2. Operation indicator (red) and setting indicator (green).

E2EQ-X15X1

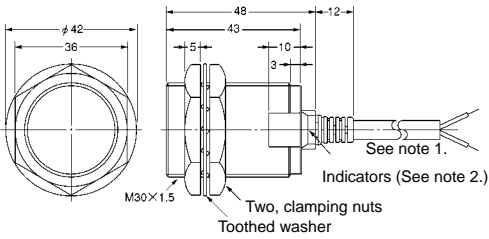

- Note:**
1. Vinyl-insulated round cable (flame-resistant), 6 dia. 2/3 conductors (conducting cross-sectional area: 0.5 mm²; insulator diameter: 1.9 mm) Standard length: 2 m Cable extension (through a single metal conduit): 200 m max.
 2. Operation indicator (red) and setting indicator (green).

E2EQ-X4X1-M1J

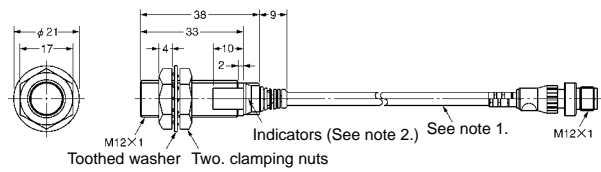

- Note:**
1. Vinyl-insulated round cable (flame-resistant), 4 dia. (Conducting cross-sectional area: 0.3 mm²; insulator diameter: 1.3 mm) Standard length: 300 mm
 2. Operation indicator (red) and setting indicator (green).

E2EQ-X8X1-M1J

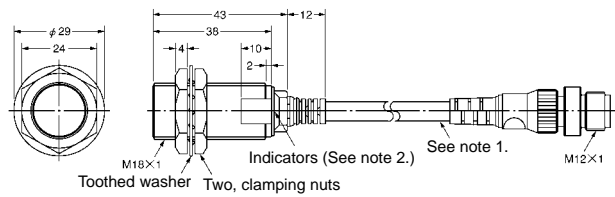

- Note:**
1. Vinyl-insulated round cable (flame-resistant), 5 dia. (Conducting cross-sectional area: 0.5 mm²; insulator diameter: 1.9 mm) Standard length: 300 mm
 2. Operation indicator (red) and setting indicator (green).

E2EQ-X15X1-M1J

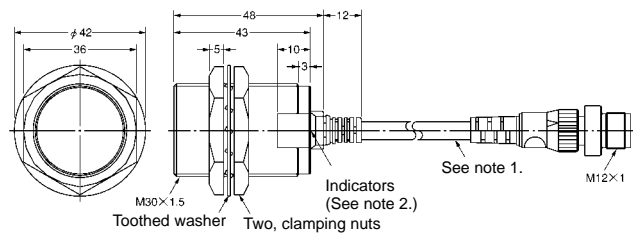

- Note:**
1. Vinyl-insulated round cable (flame-resistant), 5 dia. (Conducting cross-sectional area: 0.5 mm²; insulator diameter: 1.9 mm) Standard length: 300 mm
 2. Operation indicator (red) and setting indicator (green).

Mounting Hole Dimensions

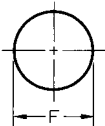

Models	F (mm)
E2EQ-X3/E2EQ-X4	12.5 ^{+0.5} ₀ dia.
E2EQ-X7/E2EQ-X8	18.5 ^{+0.5} ₀ dia.
E2EQ-X10/E2EQ-X15	30.5 ^{+0.5} ₀ dia.

Installation

■ Connection with FA Connector E2EQ-X□D1-M1GJ to Terminal Board

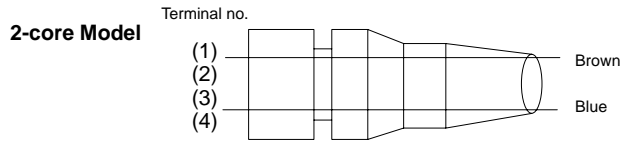
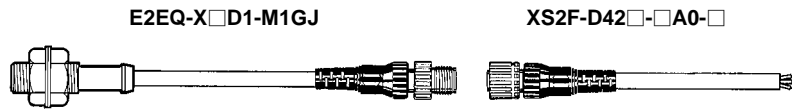

E2EQ-X□X1-M1J to Terminal Board

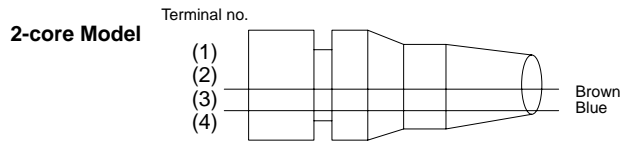
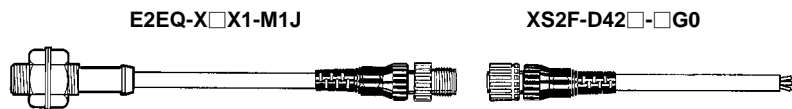

E2EQ-X□D1-M1GJ to XW3A (Connector Junction Box)

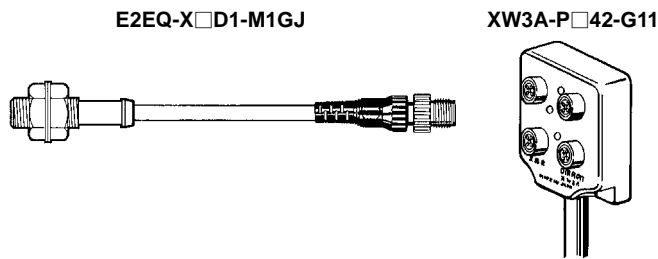

Connector Extension

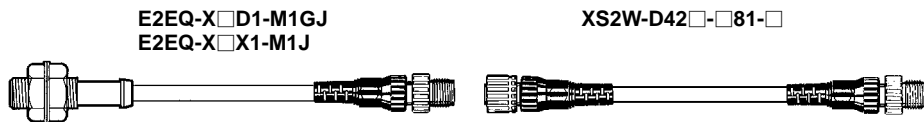

Precautions

Installation and Surroundings

Do not tighten the nut with excessive force. A washer must be used with the nut.

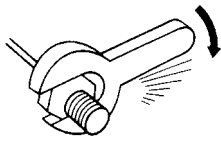

Shielded Model

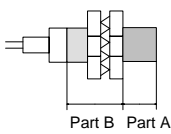

Note: The table below shows the tightening torques for part A and part B nuts. In the above example, the nut is on the sensor head side (part B) and hence the tightening torque for part B applies. If this nut is in part A, the tightening torque for part A applies instead.

Model	Part A		Part B
	Length	Torque	Torque
E2EQ-X3D1-□	24 mm	15 N • m	---
E2EQ-X7D1-□	29 mm		
E2EQ-X10D1-□	26 mm	39 N • m	78 N • m
E2EQ-X4X1-□	30 N • m		
E2EQ-X8X1-□	70 N • m		
E2EQ-X15X1-□	180 N • m		

Effects of Surrounding Metal

When mounting the E2EQ within a metal panel, ensure that the clearances given in the following table are maintained. Failure to maintain these distances may cause deterioration in the performance of the Sensor.

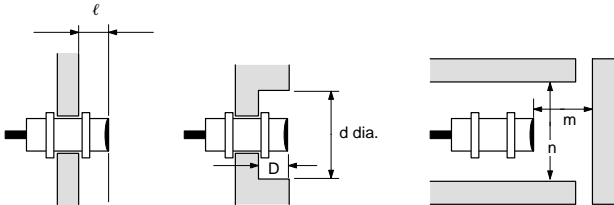

Model	E2EQ-X3D1-□	E2EQ-X7D1-□	E2EQ-X10D1-□
ℓ	0 mm	0 mm	0 mm
d	12 mm	18 mm	30 mm
D	0 mm	0 mm	0 mm
m	8 mm	20 mm	40 mm
n	18 mm	27 mm	45 mm

Model	E2EQ-X4X1-□	E2EQ-X8X1-□	E2EQ-X15X1-□
ℓ	2.4 mm	3.6 mm	6 mm
d	18 mm	2.7 mm	45 mm
D	2.4 mm	3.6 mm	6 mm
m	12 mm	24 mm	45 mm
n	18 mm	27 mm	45 mm

Mutual Interference

When installing two or more E2EQ face-to-face or side-by-side, ensure that the minimum distances given in the following table are maintained.

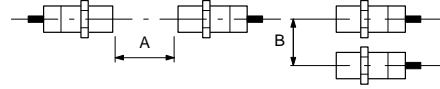

Model	A	B
E2EQ-X3D1-□	30 mm	20 mm
E2EQ-X7D1-□	50 mm	35 mm
E2EQ-X10D1-□	100 mm	70 mm
E2EQ-X4X1-□	30 mm	20 mm
E2EQ-X8X1-□	60 mm	35 mm
E2EQ-X15X1-□	110 mm	90 mm

Sensing Object

Sensing Object Material

The sensing distance is reduced for non-ferrous metals. The sensing distance for non-ferrous metal foils less than 0.01 mm thick is the same as that for ferrous metals. However, if the foil becomes so thin (e.g., from vaporization) that it loses its conductivity, then it will become undetectable.

Metal Plating

The sensing distance will change if the sensing object is plated. The following table shows the sensing distance of a plated object as a percentage of the sensing distance of an un-plated object.

Plating thickness	Mild steel	Brass
No plating	100%	100%
Zn 5 to 15 μm	90% to 120%	95% to 105%
Cd 5 to 15 μm	100% to 110%	95% to 105%
Ag 5 to 15 μm	60% to 90%	85% to 100%
Cu 10 to 20 μm	70% to 95%	95% to 105%
Cu 5 to 15 μm	---	95% to 105%
Cu (5 to 10 μm) + Ni (10 to 20 μm)	75% to 95%	---
Cu (5 to 10 μm) + Ni (10 μm) + Cr (0.3 μm)	75% to 95%	---

Parallel Connection (OR Circuit)

When constructing OR circuits by connecting 2 or more Proximity Sensors in parallel, the leakage current through the load will be 0.8 mA times n, where n is the number of Proximity Sensors connected in parallel.

Direct Connection to a Power Supply

Never connect the Proximity Sensor directly to a power supply without a load in the circuit.

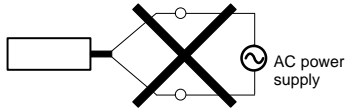
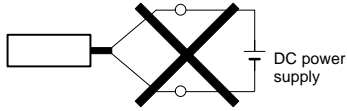

Direct Connection to a Power Supply

Never connect the Proximity Sensor directly to a power supply without a load in the circuit.

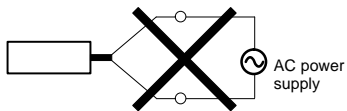
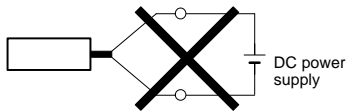

ALL DIMENSIONS SHOWN ARE IN MILLIMETERS.

To convert millimeters into inches, multiply by 0.03937. To convert grams into ounces, multiply by 0.03527.

Cat. No. D055-E1-3 **In the interest of product improvement, specifications are subject to change without notice.**

OMRON Corporation

Industrial Automation Company

Industrial Sensors Division
Sensing Devices and Components Division H.Q.
Shiokoji Horikawa, Shimogyo-ku,
Kyoto, 600-8530 Japan
Tel: (81)75-344-7068/Fax: (81)75-344-7107

Printed in Japan
0201-1M (1093) (A)