

CTS Slide

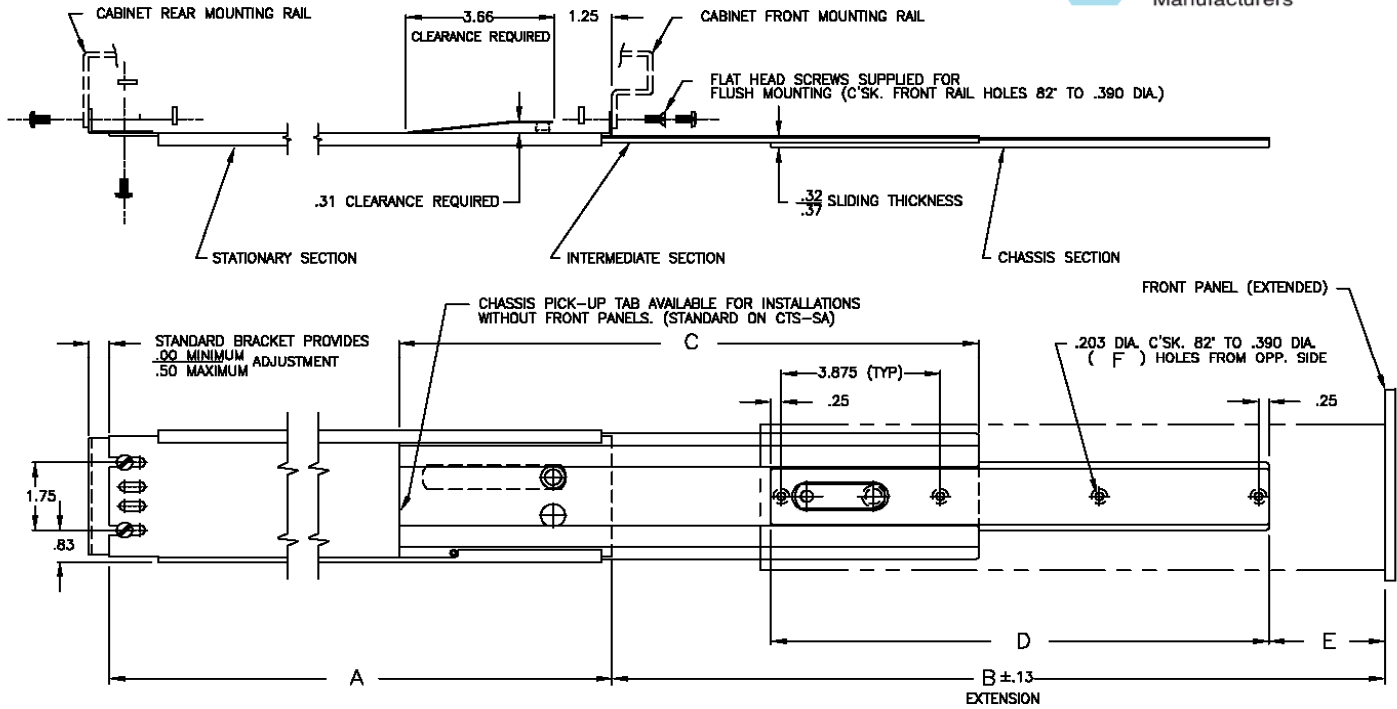

Catalog Number	A	B (min)	B (max)	C	D	E (min)	E (max)	F	Load Capacity
CTS-110	10.00	9.44	11.19	9.00	8.25	0.00	1.75	3	175 LBS.
CTS-112	12.00	10.81	14.56	11.00	8.25	0.00	3.75	3	175 LBS.
CTS-114	14.00	14.88	16.75	13.00	12.13	0.00	1.88	4	175 LBS.
CTS-116	16.00	15.75	19.63	15.00	12.13	0.00	3.88	4	175 LBS.
CTS-118	18.00	21.63	23.63	17.00	16.00	0.00	2.00	5	175 LBS.
CTS-120	20.00	23.63	27.63	19.00	16.00	0.00	4.00	5	175 LBS.
CTS-122	22.00	26.25	31.63	21.00	16.00	0.63	6.00	5	175 LBS.
CTS-124	24.00	28.25	34.63	23.00	16.00	1.63	8.00	5	175 LBS.

TO ORDER, SPECIFY



Stationary Section
 1 - Cabinet Mount
 2 - Strap Mount
 4 - Closed Slot

Length

AR - Automatic Release if desired

For information on mounting slides to Off-Set mounting rail see page 26.

For information on Strap Mount option see page 27.

Notes

- Right hand shown, left hand opposite.
- Finish: All standard slides are coated with Poxylube™ dry film lubricant.
- All standard slides are designed to lock-out in the extended position and are available with an optional automatic release if lock-out is not desirable.
- Standard hardware packages include all the hardware necessary to mount your Chassis Trak® slides:
 - Rear mounting bracket (B-131) included
 - Bar Nuts (CA8056-06-0020)
 - #10-32 screws and keps nuts
- All sliding members of the standard slide are made from cold rolled steel.
- All Chassis Trak® solid bearing slides are supplied with a quick disconnect feature.
- Optional mounting patterns, slide lengths and extensions are available.
- Pickup tab available for units without a front panel.
- For optional mounting brackets see page 35.

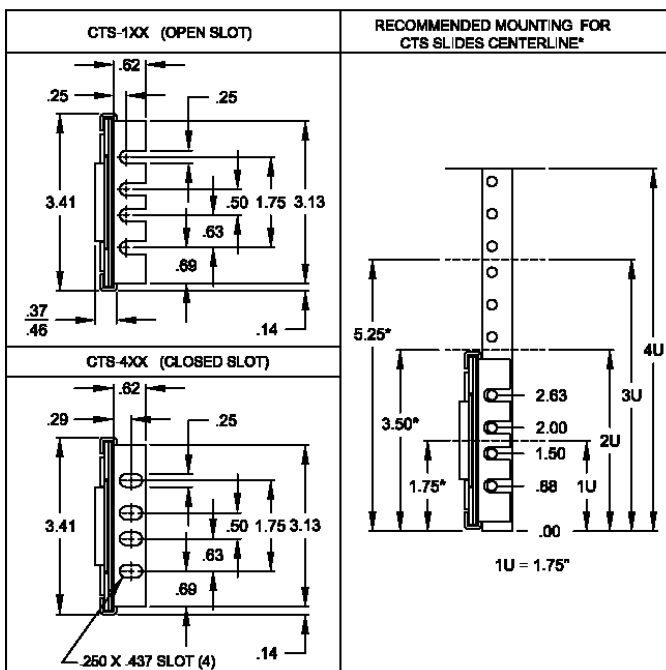

CTS and CTRS Special Application



Slide for Off-Set Leg Mounting Rail

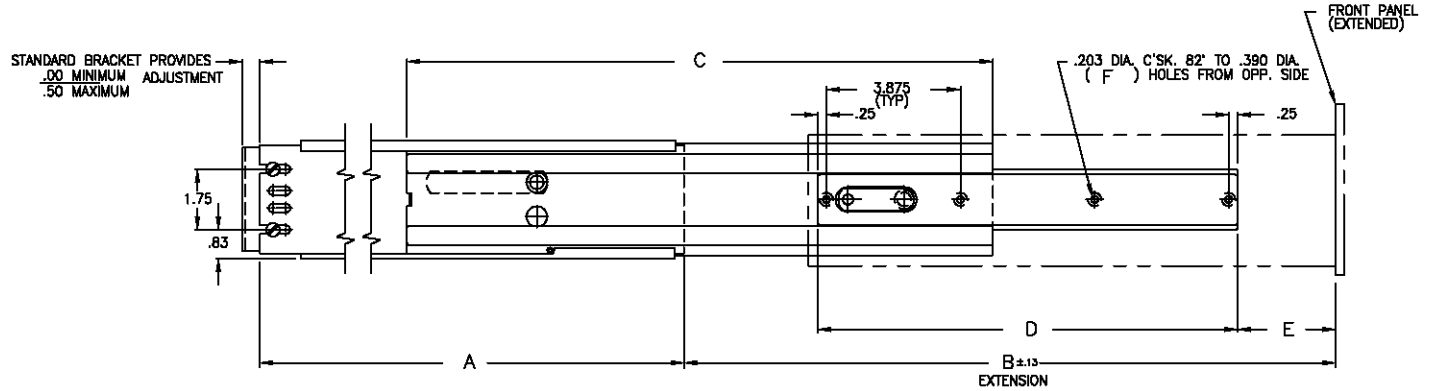
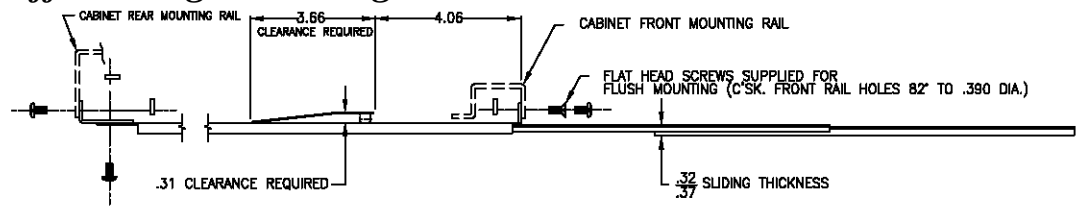

Catalog Number	A	B (min)	B (max)	C	D	E (min)	E (max)	F	Load Capacity
CTS-SA-114	14.00	13.50	14.25	13.00	12.13	0.0	.75	4	175 LBS.
CTS-SA-116	16.00	14.06	16.81	15.00	12.13	0.0	2.75	4	175 LBS.
CTS-SA-118	18.00	18.81	19.69	17.00	16.00	0.0	.88	5	175 LBS.
CTS-SA-120	20.00	20.81	23.69	19.00	16.00	0.0	2.88	5	175 LBS.
CTS-SA-122	22.00	23.31	27.69	21.00	16.00	.50	4.88	5	175 LBS.
CTS-SA-124	24.00	25.31	30.69	23.00	16.00	1.50	6.88	5	175 LBS.

TO ORDER, SPECIFY
CTS-SA - [] - []

Stationary Section
 1 - Cabinet Mount Length AR - Automatic Release if desired
 4 - Closed Slot

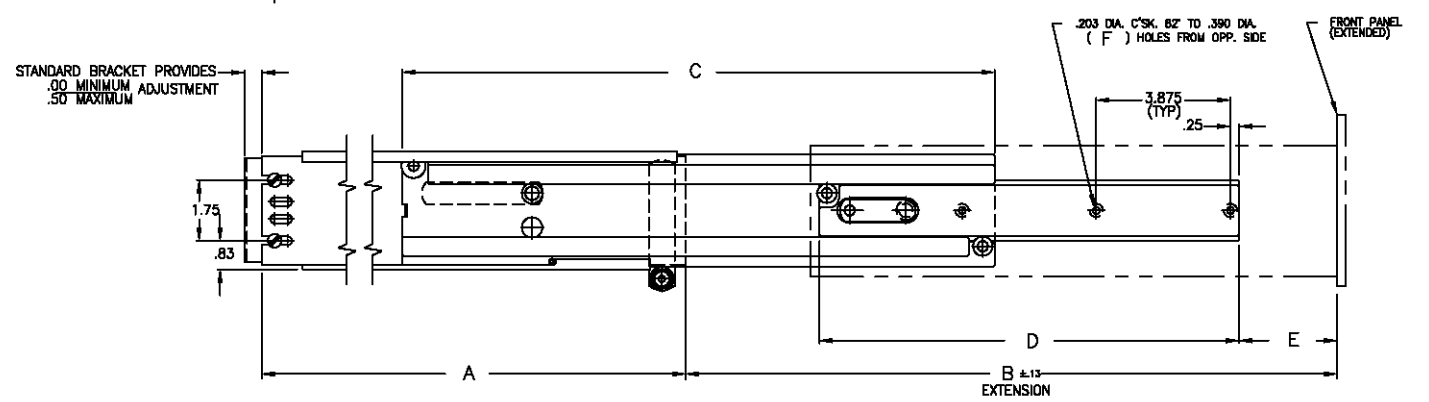
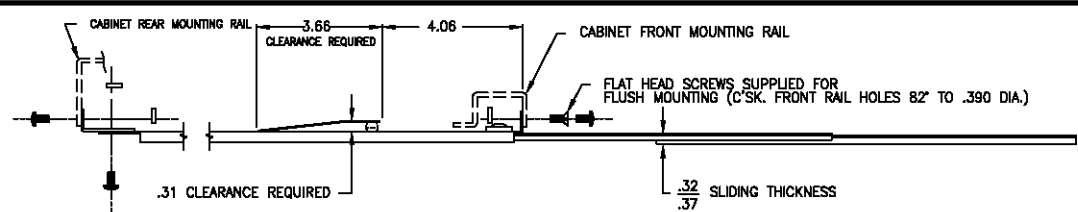

TO ORDER, SPECIFY
CTRS-SA - [] - []

Stationary Section
 1 - Cabinet Mount Length AR - Automatic Release if desired
 4 - Closed Slot

Catalog Number	A	B (min)	B (max)	C	D	E (min)	E (max)	F	Load Capacity
CTRS-SA-114	14.00	13.50	14.25	13.00	12.13	0.0	.75	4	175 LBS.
CTRS-SA-116	16.00	14.06	16.81	15.00	12.13	0.0	2.75	4	175 LBS.
CTRS-SA-118	18.00	18.81	19.69	17.00	16.00	0.0	.88	5	175 LBS.
CTRS-SA-120	20.00	20.81	23.69	19.00	16.00	0.0	2.88	5	175 LBS.
CTRS-SA-122	22.00	23.31	27.69	21.00	16.00	.50	4.88	5	175 LBS.
CTRS-SA-124	24.00	25.31	30.69	23.00	16.00	1.50	6.88	5	175 LBS.

Strap Mounting Option

C-230 Strap Mount

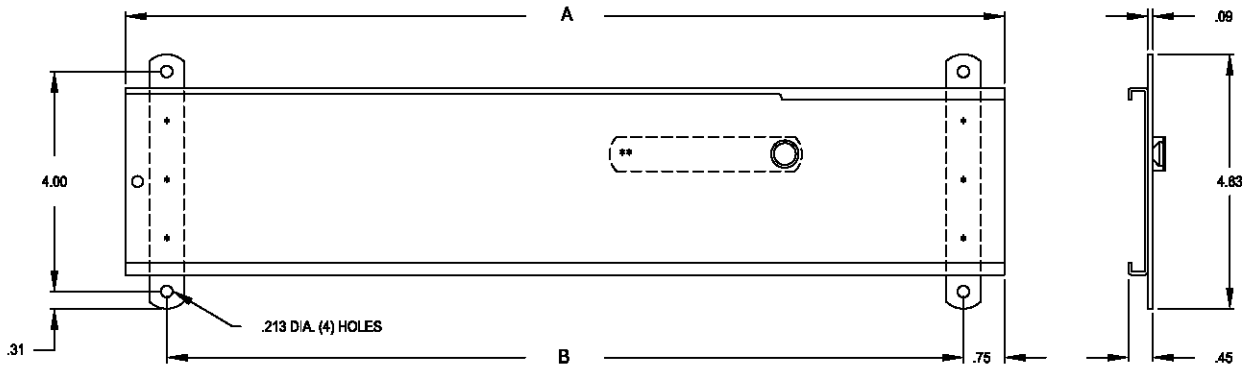

A	B
12.00	10.50
14.00	12.50
16.00	14.50
18.00	16.50
20.00	18.50
22.00	20.50
24.00	22.50

Notes

- To order, specify **C-230-S-2-XX** see pages 14-15 for more information.
- Strap mount slides are not designed to accommodate the standard EIA hole pattern.
- All slides requires a .31" clearance behind the spring and button assembly for proper operation.

C-300 Strap Mount

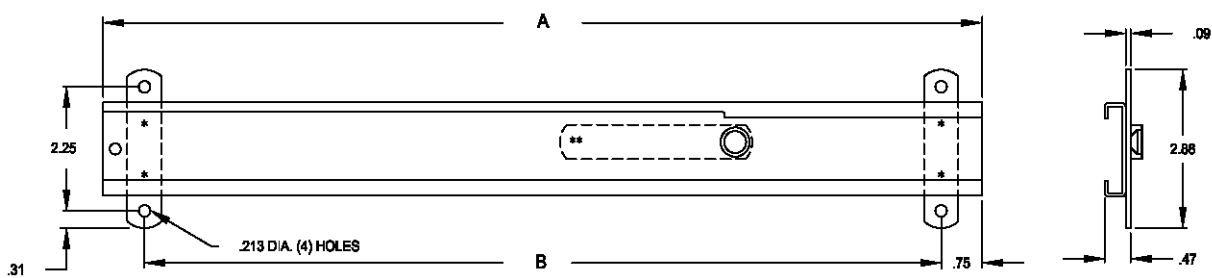

A	B
10.00	8.50
12.00	10.50
14.00	12.50
16.00	14.50
18.00	16.50
20.00	18.50
22.00	20.50
24.00	22.50
26.00	24.50
28.00	26.50
30.00	28.50

Notes

- To order, specify **C-300-S-2-XX** see pages 16-17 for more information.
- Strap mount slides are not designed to accommodate the standard EIA hole pattern.
- All slides requires a .31" clearance behind the spring and button assembly for proper operation.

CTS Strap Mount



A	B
12.00	10.50
14.00	12.50
16.00	14.50
18.00	16.50
20.00	18.50
22.00	20.50
24.00	22.50

Notes

- To order, specify **CTS-2-XX** see pages 18-19 for more information.
- Strap mount slides are not designed to accommodate the standard EIA hole pattern.
- All slides requires a .31" clearance behind the spring and button assembly for proper operation.

Optional Mounting Brackets

Matrix For Solid Bearing Slides & Appropriate Rear Mounting Brackets with Range of Extension

	B-131*	B-131-2	B-131-2.5	B-131-3	B-131-3.5	B-131-4	B-307-1 B-814-1	B-307-2 B-814-2	B-810-1	B-810-2
C-230-D	0 to .50	.44 to 1.06	.94 to 1.56	1.44 to 2.06	1.94 to 2.56	2.44 to 3.06	0 to 4.00	0 to 8.00		
C-230-S	0 to .50	.44 to 1.06	.94 to 1.56	1.44 to 2.06	1.94 to 2.56	2.44 to 3.06	0 to 4.00	0 to 8.00		
CTD	0 to .50	.44 to 1.06	.94 to 1.56	1.44 to 2.06	1.94 to 2.56	2.44 to 3.06	0 to 4.00	0 to 8.00		
CTS	0 to .50	.44 to 1.06	.94 to 1.56	1.44 to 2.06	1.94 to 2.56	2.44 to 3.06	0 to 4.00	0 to 8.00		
CTR D	0 to .50	.44 to 1.06	.94 to 1.56	1.44 to 2.06	1.94 to 2.56	2.44 to 3.06	0 to 4.00	0 to 8.00		
CTR S	0 to .50	.44 to 1.06	.94 to 1.56	1.44 to 2.06	1.94 to 2.56	2.44 to 3.06	0 to 4.00	0 to 8.00		
CTHD	0 to .50	.44 to 1.06	.94 to 1.56	1.44 to 2.06	1.94 to 2.56	2.44 to 3.06			0 to 4.00	0 to 8.00
CTHS	0 to .50	.44 to 1.06	.94 to 1.56	1.44 to 2.06	1.94 to 2.56	2.44 to 3.06			0 to 4.00	0 to 8.00
CTHR D	0 to .50	.44 to 1.06	.94 to 1.56	1.44 to 2.06	1.94 to 2.56	2.44 to 3.06			0 to 4.00	0 to 8.00
CTHR S	0 to .50	.44 to 1.06	.94 to 1.56	1.44 to 2.06	1.94 to 2.56	2.44 to 3.06			0 to 4.00	0 to 8.00
C-857	0 to .50	.44 to 1.06	.94 to 1.56	1.44 to 2.06	1.94 to 2.56	2.44 to 3.06				

Note brackets are made from 16 gauge C.R.S. — Standard finish: clear zinc commercial plating

*Supplied with standard slides

CATALOG NUMBER	A
B-131	1.56
B-131-2	2.00
B-131-2.5	2.50
B-131-3	3.00
B-131-3.5	3.50
B-131-4	4.00

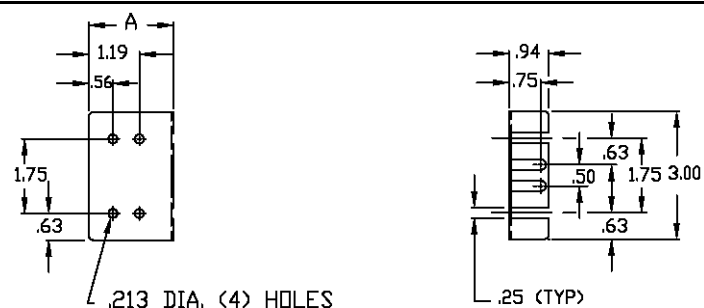
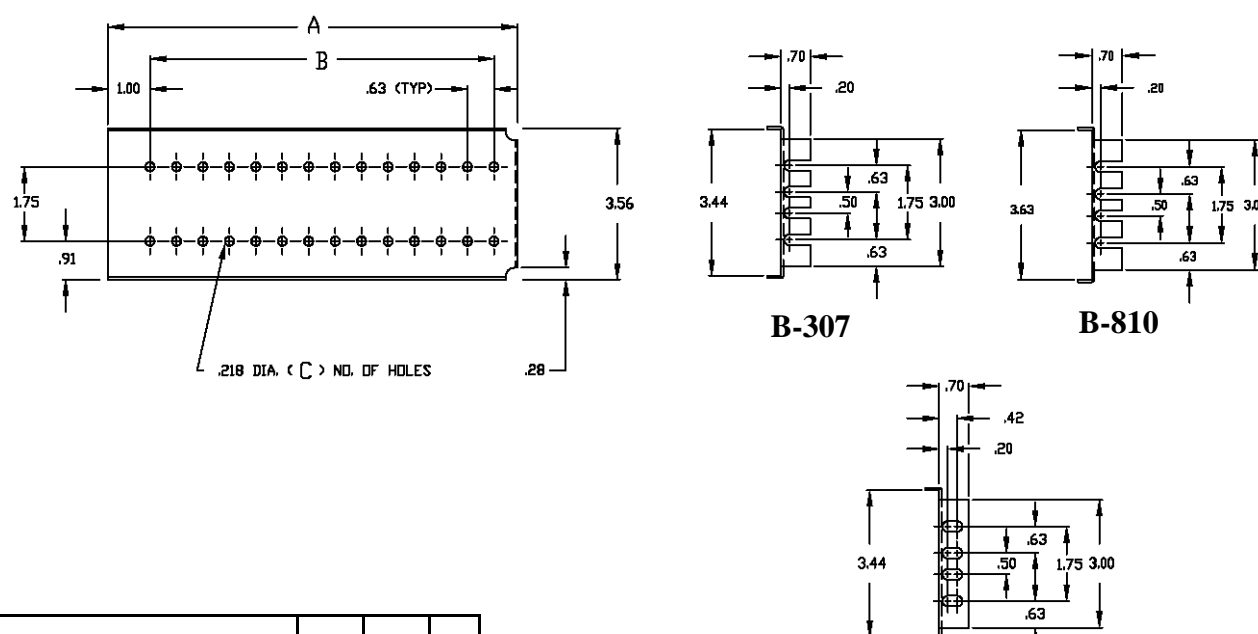
CATALOG NUMBER	A	B	C
B-307-1 / B-810-1 / B-814-1	5.94	4.38	16
B-307-2 / B-810-2 / B-814-2	9.69	8.13	28