

LOC	DIST	REVISIONS			
P	LTR	DESCRIPTION	DATE	DWN	APVD
G1		REV: MCO-40026404MCO	19NOV2015	HG	RA

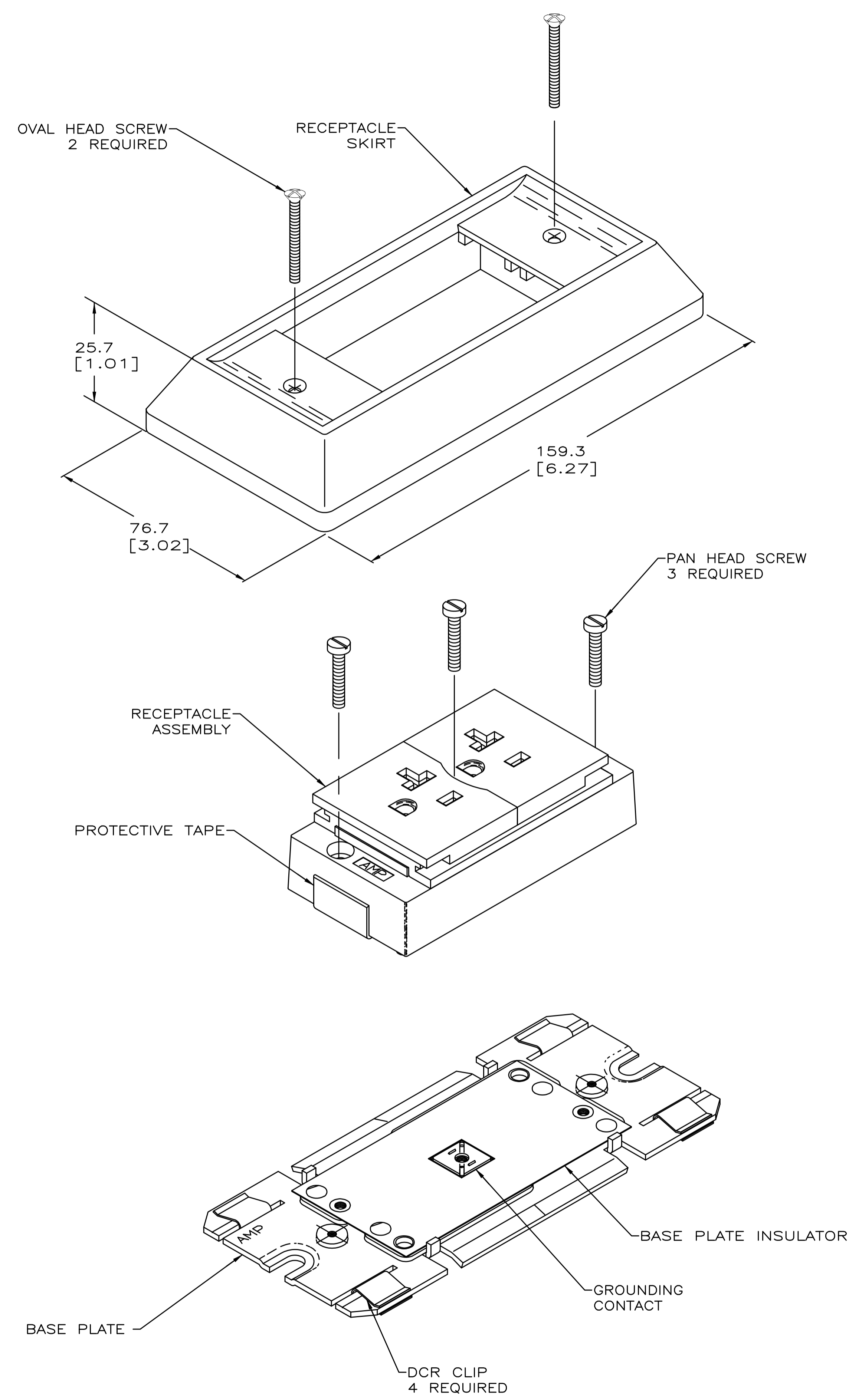

- ⚠ ALL DIMENSIONS SHOWN ARE MAXIMUM UNLESS OTHERWISE SPECIFIED.
- 2. HARDWARE SHIPPED NOT ASSEMBLED.
- ⚠ MATERIAL: SKIRT - ABS MOLDING COMPOUND. RECEPTACLE ASSEMBLY - SLIDING COVER, POLYCARBONATE MOLDING COMPOUND; BASE, PBT MOLDING COMPOUND. BASE PLATE - PREGALVANIZED STEEL. BASE PLATE INSULATOR - VULCANIZED FIBRE. HARDWARE - ZINC PLATED STEEL. DCR CLIP - STAINLESS STEEL. TERMINALS AND GROUNDING CONTACT - COPPER ALLOY.

BLACK	553947-1
RECEPTACLE COLOR	PART NO.

THIS DRAWING IS A CONTROLLED DOCUMENT.		DWG: G. GARRETT 18MAR97	TE Connectivity	
DIMENSIONS: mm [INCHES]		CHK: G. GARRETT 18MAR97	NAME: J. KILPATRICK 18MAR97	
TOLERANCES UNLESS OTHERWISE SPECIFIED:		PRODUCT SPEC	APPLICATION SPEC	
0 PLC	±	114-6008	SIZE: A1	CAGE CODE: 00779
1 PLC	±		DRAWING NO: 553947	RESTRICTED TO: -
2 PLC	±		WEIGHT: -	
3 PLC	±		CUSTOMER DRAWING	
4 PLC	±		SCALE: 1:1	SHEET: 1 OF 1
ANGLES	±		REV: G1	
FINISH	3			