

T&B[®] TY-RAP[®] INSTALLATION TOOL

CAT. NO. WT3D

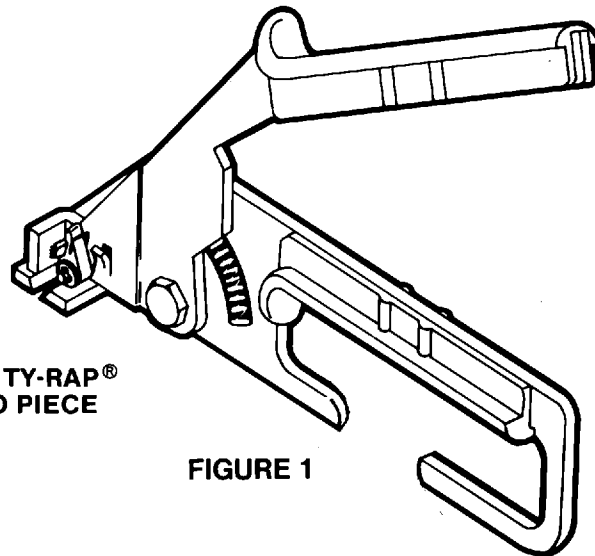

INSTALLS SELF LOCKING TY-RAP[®] CABLE TIES AND T&B TWO PIECE LASHING TIES.

FIGURE 1

**WEAR SAFETY GOGGLES
WHEN USING TOOL**

INSTALLING INSTRUCTIONS

1. Place tool on tie as shown. (See Figure 2).
2. Squeeze handle as many times as necessary to tighten tie to desired tension.
DO NOT OVER TIGHTEN TIE.
3. Release handle pressure to the minimum necessary to hold nose of tool against tie head and rotate tool 1/2 turn - then squeeze handle to pull the cut-off tail from tie.
4. Tool will install lashing ties, but is not designed to cut ties wider than .500" [12.7 mm].

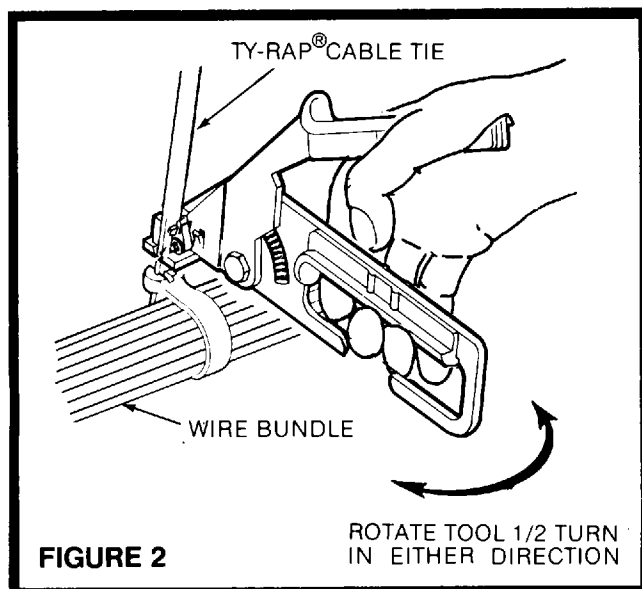

FIGURE 2

For parts or service, contact the tool service center at 1-800-284-TOOL (8665).

WARRANTY: Thomas & Betts sells this product with the understanding that the user will perform all necessary tests to determine the suitability of the product for its intended use. Thomas & Betts manufactures its goods and tools in a manner to be free of defects. Should any defect occur in its goods within two years (or tools within ninety days) of the date of purchase, Thomas & Betts, upon prompt notification, will at its option, exchange or repair the goods or tools or refund the purchase price. Proof of purchase required.

Limitations and Exclusions: THIS WARRANTY IS IN LIEU OF ALL OTHER REPRESENTATIONS AND EXPRESSED AND IMPLIED WARRANTIES (INCLUDING THE IMPLIED WARRANTIES OF MERCHANTABILITY AND FITNESS FOR USE) AND UNDER NO CIRCUMSTANCES SHALL THOMAS & BETTS BE LIABLE FOR ANY INCIDENTAL OR CONSEQUENTIAL PROPERTY DAMAGES OR LOSSES OF ANY KIND.

Thomas & Betts Corporation
1555 Lynnfield Road, Memphis, Tennessee 38119
Printed in U.S.A.

Made in U.S.A.

TA00646 B

NOTE 4

NOTE 3