



### Main

Range of product	Harmony K
Product or component type	Complete cam switch
Component name	K150
[I <sub>th</sub> ] conventional free air thermal current	150 A
Mounting location	Front
Fixing mode	4 holes
Cam switch head type	With front plate 88 x 88 mm
Type of operator	Black handle
Rotary handle padlocking	Without
Presentation of legend	With metallic legend, 1 - 2 black marking
Cam switch function	Changeover switch
Return	Without
Off position	Without Off position
Poles description	3P
Switching positions	Left: 330° Right: 30°
IP degree of protection	IP40 conforming to IEC 529 IP40 conforming to NF C 20-010

### Complementary

Switching angle	30 °
[U <sub>i</sub> ] rated insulation voltage	690 V degree of pollution 3 conforming to EN 60947-1 690 V degree of pollution 3 conforming to IEC 60947-1
Short-circuit current	25000 A
Short-circuit protection	200 A by cartridge fuse, type gG
[U <sub>imp</sub> ] rated impulse withstand voltage	6 kV conforming to EN 947-1 6 kV conforming to IEC 947-1
Contact operation	Slow-break
Positive opening	With
Electrical connection	Captive screw clamp terminals flexible, 2 x 50 mm <sup>2</sup> Captive screw clamp terminals solid, 2 x 70 mm <sup>2</sup>
Tightening torque	2.5 N.m

Switching capacity in mA	150000 mA DC at 140 V 3 contact(s) for resistive load (T = 1 ms) 150000 mA DC at 24 V 1 contact(s) for inductive load (T = 50 ms) 150000 mA DC at 24 V 1 contact(s) for resistive load (T = 1 ms) 150000 mA DC at 48 V 1 contact(s) for resistive load (T = 1 ms) 150000 mA DC at 48 V 2 contact(s) for inductive load (T = 50 ms) 150000 mA DC at 48 V 2 contact(s) for resistive load (T = 1 ms) 150000 mA DC at 70 V 3 contact(s) for inductive load (T = 50 ms) 150000 mA DC at 70 V 3 contact(s) for resistive load (T = 1 ms) 150000 mA DC at 95 V 2 contact(s) for resistive load (T = 1 ms) 50000 mA DC at 30 V 1 contact(s) for inductive load (T = 50 ms) 50000 mA DC at 60 V 2 contact(s) for inductive load (T = 50 ms) 50000 mA DC at 90 V 3 contact(s) for inductive load (T = 50 ms)
Mechanical durability	300000 cycles
CAD overall width	88 mm
CAD overall height	88 mm
CAD overall depth	172 mm
Product weight	0.76 kg

## Environment

Standards	EN/IEC 60947-3
Product certifications	CULus 240 V 15 hp 1 phase CULus 240 V 25 hp 3 phases CULus 480 V 40 hp 3 phases CULus 120 V 7.5 hp 1 phase
Protective treatment	TC
Ambient air temperature for operation	-25...55 °C
Ambient air temperature for storage	-40...70 °C
Overvoltage category	Class II conforming to IEC 60536 Class II conforming to NF C 20-030

## Contractual warranty

Warranty period	18 months
-----------------	-----------

Dimensions

Front Mounting

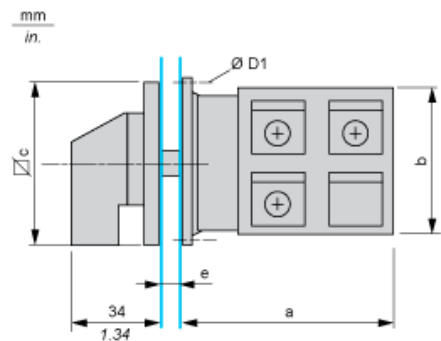

e support panel thickness 0.5 to 5.5 mm / 0.02 to 0.22 in in.

a		b		c		D1	
mm	in.	mm	in.	mm	in.	mm	in.
132.5	5.22	88	3.46	88	3.46	5.4	0.21

Panel Cut-Out

Front Mounting

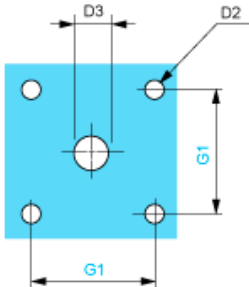

D2		D3		G1	
mm	in.	mm	in.	mm	in.
6	0.24	13	0.51	68	2.68

---

Link Positions (Factory Mounted)

---

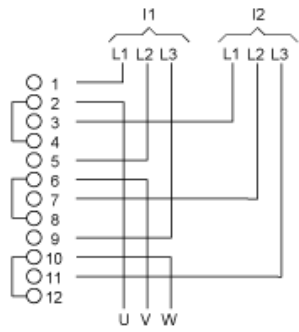

I1     Input 1  
I2     Input 2

---

Marking

---



---

Angular Position of Switch

---



---

Switching Program

---





---

Convention Used for Switching Program Representation

---

Contact closed

Contact closed in 2 positions and maintained between the 2 positions

Sealed assembly for auto-maintain control

Overlapping contacts

Spring return position: for a switching angle of 90°, spring return is over 30° after the last position (for a maximum of 3 simultaneous contacts).

Example:

