

# iBridge and iBridge Ultra

2.00 mm Board to Cable Connectors



## ■ TABLE OF CONTENTS

---

### OVERVIEW

General	03
Technical Details	04
Features	05
Electrical and Mechanical Characteristics	10
Ordering Information	13

### MALE CONNECTORS

Vertical Male SMT	14
Vertical Male DIP	16
Right Angle Male SMT	18
Right Angle Male DIP	20

<b>iBridge - FEMALE CABLE CONNECTOR &amp; CABLE ASSEMBLIES</b>	22
--	----

<b>iBridge Ultra - FEMALE CABLE CONNECTOR &amp; CABLE ASSEMBLIES</b>	29
--	----

<b>PART NUMBER INDEX</b>	36
--------------------------	----

# iBridge and iBridge Ultra

## BOARD TO CABLE CONNECTOR —

### GENERAL



**iBridge  
Female and  
Male Connector**

The iBridge product family is a comprehensive interconnect solution that is designed for board-to-cable connections in all applications. It is especially suitable for use in highly demanding systems that require reliability and robust connections. It is well suited for automotive, LED, telecommunications and data-transmission devices.

The single row iBridge connectors could be used in a wide application temperature range (-55°C to +125°C). Engineer can select between two termination options depending on the application: SMT for maximum PCB real estate usage or DIP solder for extra mechanical strain relief. To take advantage of maximum PCB real estate usage while not compromising on the PCB retention force, the SMT version features solder brackets on both sides.

In addition, SMT termination coplanarity is 100% guaranteed, less than 0.10 mm on all contacts.

The iBridge connectors are engineered for every application concern, including severe vibration. The connectors have natural coloured housing to minimize light energy absorption.

#### Features

- Current carrying capacity: up to 5 A per contact
- Locking tangs for secure retention
- Blanked contacts to ensure robustness and coplanarity
- Polarized contacts and housing for fool-proof mating
- Latches on both sides of female connectors to provide positive locking
- High temperature insulator material (UL94 V-0)

# iBridge and iBridge Ultra

## BOARD TO CABLE CONNECTOR —

### GENERAL



**iBridge Ultra  
for rugged  
high vibration  
applications**

The iBridge Ultra is an enhancement of the iBridge cable connector system and is designed with the Automotive industry in mind, but its high contact housing retention force and versatility makes it suitable for many harsh operating environments. Each unit features a redesigned female cable connector with a locking mechanism (retainer), allowing a secure connection without the need for specialized tools.

The uniquely engineered retainer is capable of achieving contact housing retention force of 50N per contact, hence minimizing the potential of accidental disconnection even in high vibration applications. For pin counts of 10 pins and above, a box feature is added to strengthen the retainer.

The iBridge Ultra is mating compatible with the standard iBridge male PCB connector, therefore layout changes are not needed on existing PCB designs.

# iBridge and iBridge Ultra

## BOARD TO CABLE CONNECTOR —

### TECHNICAL DETAILS

<b>Pitch</b>	2.00 mm
<b>No. of Pins</b>	2, 3, 4, 5, 6, 8, 10, 12
<b>Current rating per contact</b>	up to 5 A (depends on cable)
<b>Termination</b>	Male connector DIP and SMT, Female connector Crimp
<b>Cable</b>	Discrete wire AWG 22 and AWG 24
<b>Variants</b>	Vertical male connector, Right angle male connector, Female connector with 180° cable outlet

### SSL-LIGHTING TECHNOLOGY

Connectors with **natural color insulation** bodies prevent shadow formation in lighting applications, e.g. LED strips with transparent diffusion disks. Thus ensuring uniform light distribution.



# iBridge and iBridge Ultra

## FEATURES

### AVAILABLE CONFIGURATIONS

Right angle male -  
Female with 180° cable  
outlet

Vertical male -  
Female with 180° cable  
outlet



### LOCATING PEGS

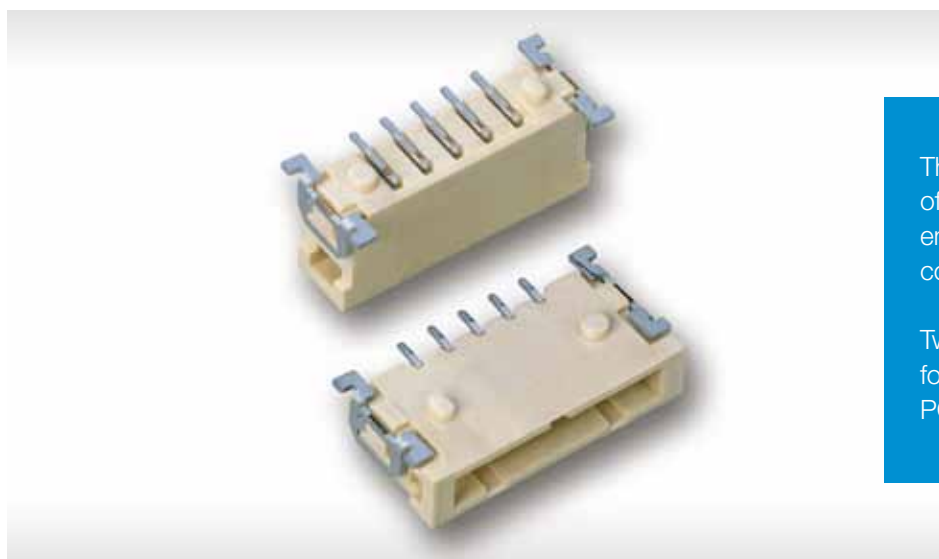

The rugged **insulation body** of the male connector ensures an optimal cable connector guide.

Two **pegs** (round and oval) for exact positioning on the PCB.

# iBridge and iBridge Ultra

## FEATURES —

### ROBUST SOLDER BRACKETS

Ruggedized **solder brackets** provide reliable retention force and serve as integrated strain relief.

**Reinforced wall** ensures robustness and improves latching force with female cable connector.

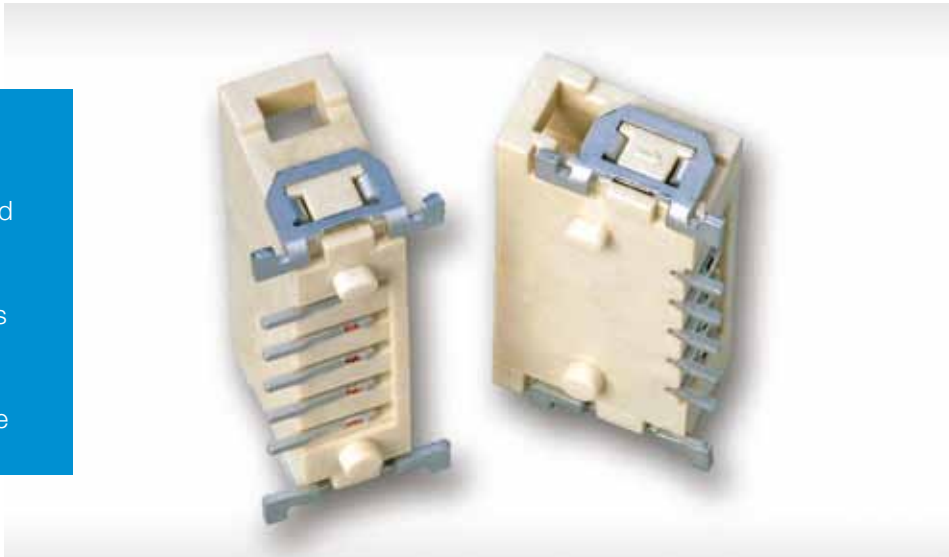

### TYPE 2 CONTACT DESIGN



**Unique contact design and housing cavity** ensures fool-proof assembly and eliminates contact stubbing during mating.

# iBridge and iBridge Ultra

## FEATURES



### BLANKED TERMINALS

**Blanked terminals without post bending** ensure robustness and precise coplanarity.

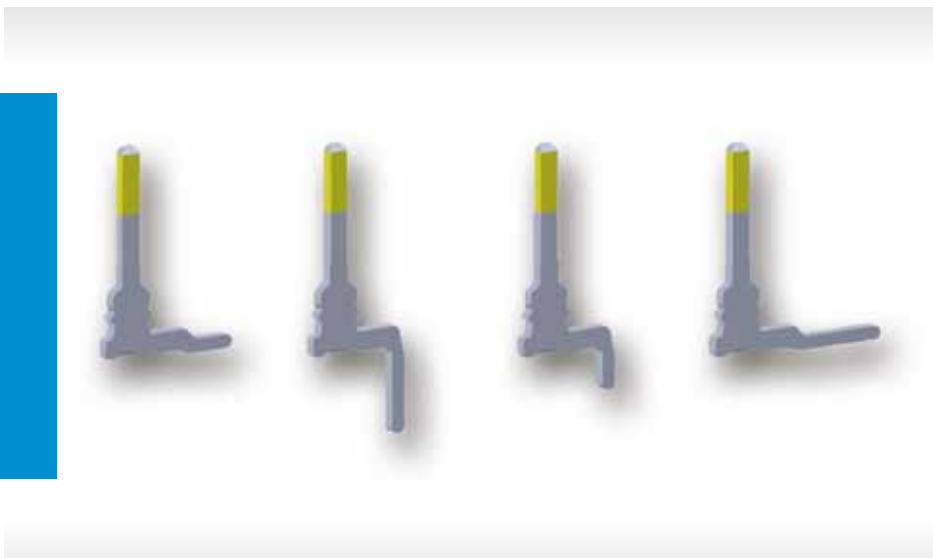

### CONTACT LOCKING



**Locking tang** ensures secure retention between contact and housing.



# iBridge and iBridge Ultra

## FEATURES —

### LATCHES

---

**Positive locking latches** provide tactile sound and feel for mating confirmation.



### INTERLOCKING

---



iBridge Ultra feature a **uniquely engineered retainer** to provide stability and retention for applications that are subjected to high vibration.

# iBridge and iBridge Ultra

## ELECTRICAL AND MECHANICAL CHARACTERISTICS

### TECHNICAL DATA

Description	Standard	Male Connector (DIP, SMT )	Female Connector (Crimp)
Climate category	DIN EN 60068-1 test b	-55 / 125 / 56	-55 / 125 / 56
Temperature range		-55 / 125 °C	-55 / 125 °C
Current rating per contact	IEC60512 test 5b	20 °C 5.0 A max.	20 °C 5.0 A max.
Air and creepage distance		contact - contact 1.6 mm	contact - contact 1.5 mm
Operating voltage	IEC 60664	<p>The permissible operating voltages depend on the customer application and on the applicable or specified safety requirements. Insulation coordination according to IEC 60664-1 has to be regarded for the complete electrical device. Therefore, the maximum creepage and clearance distances of the mated connectors are specified for consideration as a part of the whole current path. In practice, reductions in creepage or clearance distances may occur due to the conductive pattern of the printed board or the wiring used, and have to be taken into account separately. As a result the creepage and clearance distances for the application may be reduced compared to those of the connector.</p>	
Dielectric strength	IEC 60512 test 4a	contact – contact 500 V <sub>rms</sub>	
Contact resistance	IEC 60512 test 2a	< 20 mΩ	
Insulation resistance	IEC 60512 test 3a	> 1000 MΩ	
Random Vibration	IEC 60068-2-64	10 – 1000 Hz 27.8 m/s <sup>2</sup>	
Contact disturbance (during vibration test)	IEC 60512 test 2e	< 1 μs	
Shock halfsine	IEC 60512 test 6c	50 g 11 ms	
Contact disturbance (during vibration test)	IEC 60512 test 2e	< 1 μs	
Mechanical operation (Mating cycle)	IEC 60512 test 9a	Standard: min. 30 mating cycles for Sn plating Non-standard: min. 100 mating cycles for Au plating	
Insertion and withdrawal force	IEC 60512 test 13b	2 N max.	

# iBridge and iBridge Ultra

## ELECTRICAL AND MECHANICAL CHARACTERISTICS

Description	Standard	Male Connector (DIP, SMT)	Female Connector (Crimp)
Gauge retention force	IEC 60512 test 16e	-	0.15 N min.
<b>Process Conditions</b>			
Solder temperature max.	IEC 60068-2-20		
Hand soldering temperature max.		3.5 s at 350 °C	
DIP soldering temperature max.		10 s at 260 °C	
Reflow soldering temperature max.	JEDEC J-STD-020	20 - 40 s at 260 °C	
Processing temperature (Crimp connection)			0 / 55 °C
Coplanarity			< 0.1 mm
<b>Housing Material</b>			
Plastic material		LCP Natural	PA Natural
Tracking Resistance (CTI)	IEC 60112	125 V	600 V
UL Flame Rating			UL 94 V-0
<b>Contact Material</b>			
Base material			Cu alloy
Mating area			Au or Sn plating over Ni underplating
Termination area			Sn plating over Ni underplating
<b>PCB Clip and SMT Bracket Materials</b>			
Base material			Cu Alloy
Plating			Sn over Ni
<b>Product Approval</b>			
UL			E472031

# iBridge and iBridge Ultra

## ELECTRICAL AND MECHANICAL CHARACTERISTICS

### CABLE DATA

Description	Standard Cable (AWG 22)	Standard Cable (AWG 24)
Cross Section	AWG 22 / 17 x 0.16 mm	AWG 24 / 11 x 0.16 mm
Conductor	Cu wire tin-plated	
Conductor diameter	0.76 mm	0.61 mm
Marking	Magenta	
Insulation	PVC	
Insulation Thickness (Nominal)	0.43 mm	
Outer diameter	1.58 mm	1.43 mm
<b>Technical data</b>		
Temperature range	105 °C max.	
Voltage rating	300 V max.	
Dielectric strength	1500 V <sub>rms</sub>	
UL flammability	UL 94 VW-1	

# iBridge and iBridge Ultra

## BOARD TO CABLE CONNECTOR —

### ORDERING INFORMATION

---

#### No. of Positions

Standard: 2, 3, 4, 5, 6, 8, 10, 12

#### Configuration / Termination

Standard: Right Angle Male - SMT  
Right Angle Male - DIP  
Vertical Male - SMT  
Vertical Male - DIP  
Vertical Female Cable Assembly - Crimp

#### Plating / Performance

Standard: Tin (min. 30 mating cycles)  
Non-standard: Gold (min. 100 mating cycles)

#### Packaging

Standard: Tube (for all Male - SMT & DIP)  
Tape and Reel (for Right Angle Male - SMT)  
Tape and Reel with Film (for Vertical Male - SMT)  
Box (for Female Cable Assembly)  
Non-standard: Tube with Film (for Vertical Male - SMT & DIP)

# iBridge and iBridge Ultra

## VERTICAL MALE SMT

### DIMENSIONAL DRAWINGS

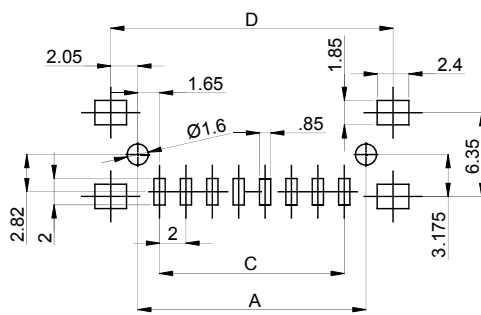
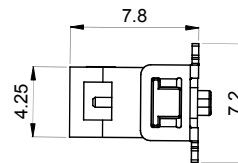
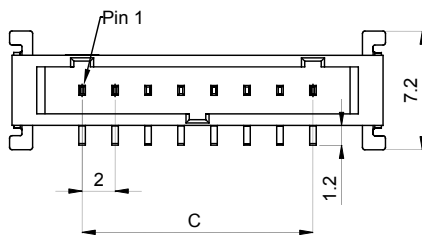
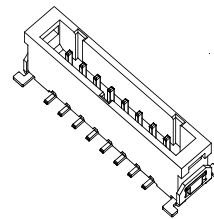
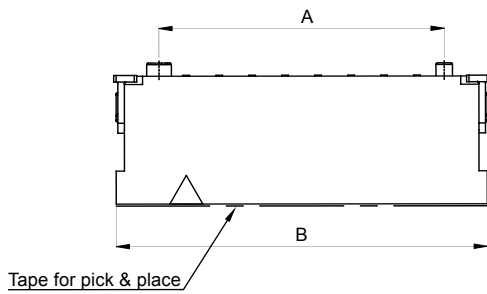

RECOMMENDED PCB LAYOUT  
TOLERANCE  $\pm 0.05$

12	25.3	30.5	22	29.4
10	21.3	26.5	18	25.4
8	17.3	22.5	14	21.4
6	13.3	18.5	10	17.4
5	11.3	16.5	8	15.4
4	9.3	14.5	6	13.4
3	7.3	12.5	4	11.4
2	5.3	10.5	2	9.4
Position	Dim A	Dim B	Dim C	Dim D

All dimensions in mm.

# iBridge and iBridge Ultra

## VERTICAL MALE SMT

### ORDERING INFORMATION

No. of Pins	Mating Cycles	Packaging	Part Number
2	30 min.	Tube	109907
2	30 min.	Tape and Reel with Film	109901
3	30 min.	Tube	109908
3	30 min.	Tape and Reel with Film	109902
4	30 min.	Tube	109909
4	30 min.	Tape and Reel with Film	109903
5	30 min.	Tube	109910
5	30 min.	Tape and Reel with Film	109904
6	30 min.	Tube	109911
6	30 min.	Tape and Reel with Film	109905
8	30 min.	Tube	109912
8	30 min.	Tape and Reel with Film	109906
10	30 min.	Tube	119929
10	30 min.	Tape and Reel with Film	119927
12	30 min.	Tube	119930
12	30 min.	Tape and Reel with Film	119928

# iBridge and iBridge Ultra

## VERTICAL MALE DIP

### DIMENSIONAL DRAWINGS

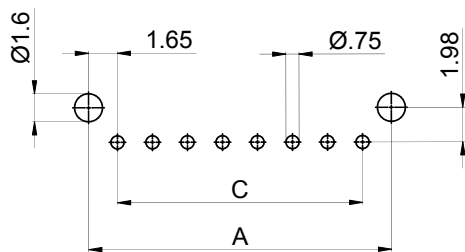
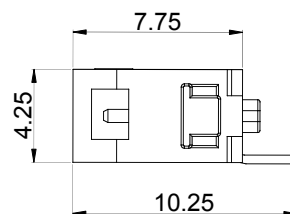
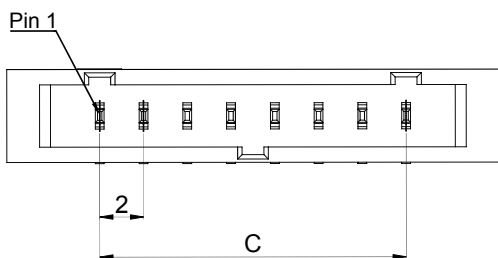
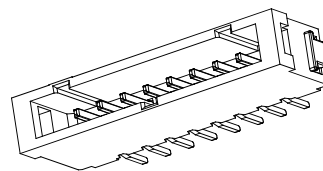
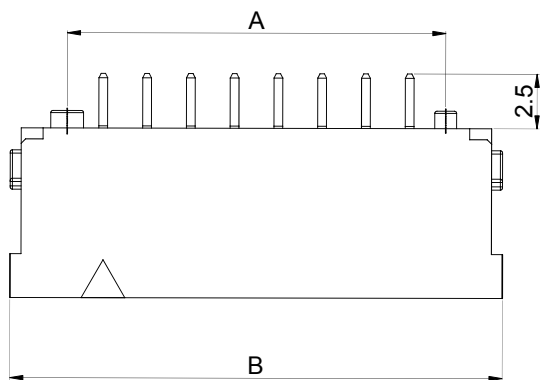

RECOMMENDED PCB LAYOUT  
TOLERANCE  $\pm 0.05$

12	25.3	30.5	22
10	21.3	26.5	18
8	17.3	22.5	14
6	13.3	18.5	10
5	11.3	16.5	8
4	9.3	14.5	6
3	7.3	12.5	4
2	5.3	10.5	2
Position	Dim A	Dim B	Dim C

All dimensions in mm.



# iBridge and iBridge Ultra

## VERTICAL MALE DIP —

### ORDERING INFORMATION

No. of Pins	Mating Cycles	Packaging	Part Number
2	30 min.	Tube	109934
3	30 min.	Tube	109935
4	30 min.	Tube	109936
5	30 min.	Tube	109937
6	30 min.	Tube	109938
8	30 min.	Tube	109939
10	30 min.	Tube	119935
12	30 min.	Tube	119936

# iBridge and iBridge Ultra

## RIGHT ANGLE MALE SMT

### DIMENSIONAL DRAWINGS

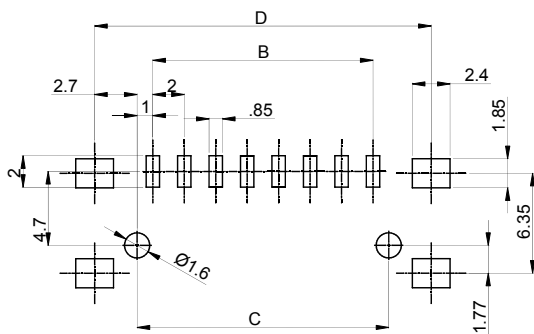
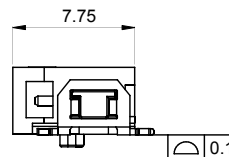
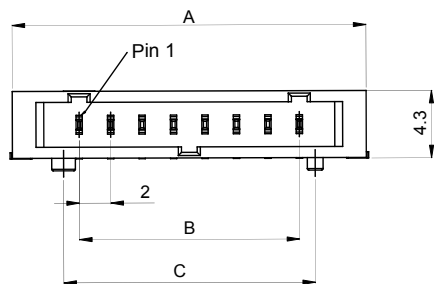
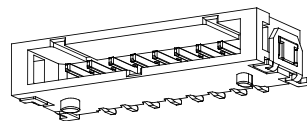
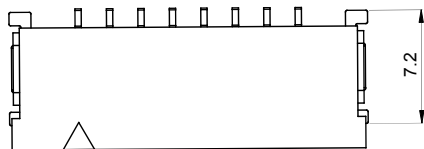

RECOMMENDED PCB LAYOUT  
TOLERANCE  $\pm 0.05$

12	30.5	22	24	29.4
10	26.5	18	20	25.4
8	22.5	14	16	21.4
6	18.5	10	12	17.4
5	16.5	8	10	15.4
4	14.5	6	8	13.4
3	12.5	4	6	11.4
2	10.5	2	4	9.4
Position	Dim A	Dim B	Dim C	Dim D

All dimensions in mm.

# iBridge and iBridge Ultra

## RIGHT ANGLE MALE SMT

### ORDERING INFORMATION

No. of Pins	Mating Cycles	Packaging	Part Number
2	30 min.	Tube	109920
2	30 min.	Tape and Reel	109914
3	30 min.	Tube	109921
3	30 min.	Tape and Reel	109915
4	30 min.	Tube	109922
4	30 min.	Tape and Reel	109916
5	30 min.	Tube	109923
5	30 min.	Tape and Reel	109917
6	30 min.	Tube	109924
6	30 min.	Tape and Reel	109918
8	30 min.	Tube	109925
8	30 min.	Tape and Reel	109919
10	30 min.	Tube	119932
10	30 min.	Tape and Reel	119903
12	30 min.	Tube	119933
12	30 min.	Tape and Reel	119908

# iBridge and iBridge Ultra

## RIGHT ANGLE MALE DIP

### DIMENSIONAL DRAWINGS

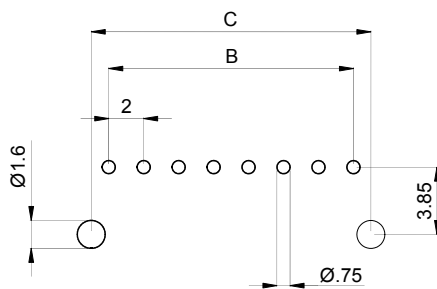
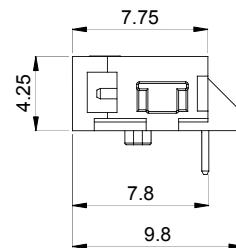
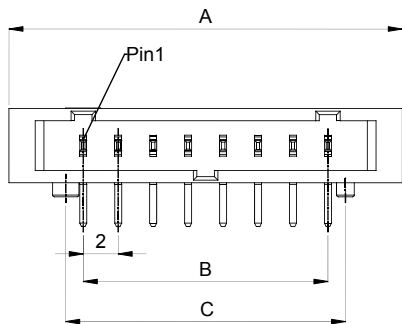
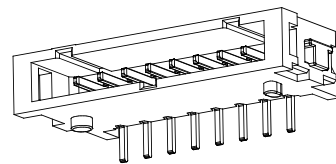
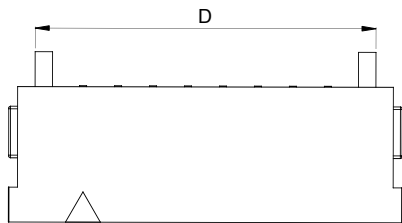

RECOMMENDED PCB LAYOUT  
TOLERANCE  $\pm 0.05$

12	30.5	22	24	27.5
10	26.5	18	20	23.5
8	22.5	14	16	19.5
6	18.5	10	12	15.5
5	16.5	8	10	13.5
4	14.5	6	8	11.5
3	12.5	4	6	9.5
2	10.5	2	4	7.5
Position	Dim A	Dim B	Dim C	Dim D

All dimensions in mm.

# iBridge and iBridge Ultra

## RIGHT ANGLE MALE DIP

### ORDERING INFORMATION

No. of Pins	Mating Cycles	Packaging	Part Number
2	30 min.	Tube	109941
3	30 min.	Tube	109942
4	30 min.	Tube	109943
5	30 min.	Tube	109944
6	30 min.	Tube	109945
8	30 min.	Tube	109946
10	30 min.	Tube	119938
12	30 min.	Tube	119939

# iBridge and iBridge Ultra

## iBridge - FEMALE CABLE CONNECTOR

### DIMENSIONAL DRAWINGS

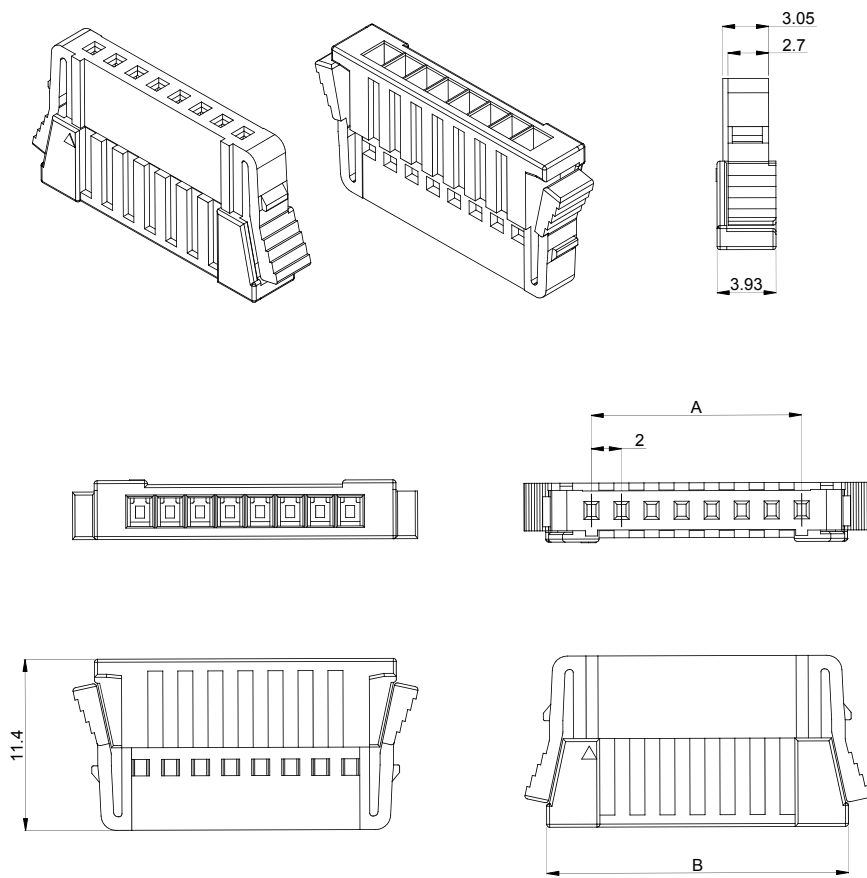

Pos	Dim A	Dim B
2	2.00	8.1
3	4.00	10.1
4	6.00	12.1
5	8.00	14.1
6	10.00	16.1
8	14.00	20.1
10	18.00	24.1
12	22.00	28.1

All dimensions in mm.

# iBridge and iBridge Ultra

## iBridge - FEMALE CABLE CONNECTOR

### ORDERING INFORMATION

No. of Pins	Termination	Packaging	Part Number
2	Crimp	Bag/ 800 pcs	119949
3	Crimp	Bag/ 800 pcs	119950
4	Crimp	Bag/ 800 pcs	119951
5	Crimp	Bag/ 800 pcs	119952
6	Crimp	Bag/ 800 pcs	119953
8	Crimp	Bag/ 800 pcs	119954
10	Crimp	Bag/ 500 pcs	119955
12	Crimp	Bag/ 500 pcs	119956

Contacts	Cable Type	Termination	Packaging	Part Number
Female Contact	AWG 22, 24	Crimp	Reel/ 500 pcs	119946
Female Contact	AWG 22, 24	Crimp	Reel/ 10000 pcs	119945

Tool	Cable Type	Packaging	Part Number
Hand Crimp	AWG 22, 24	1 pcs	335003

Hand crimp tool set consists of upper and lower tool.

# iBridge and iBridge Ultra

## iBridge - FEMALE CABLE ASSEMBLIES

### DIMENSIONAL DRAWINGS

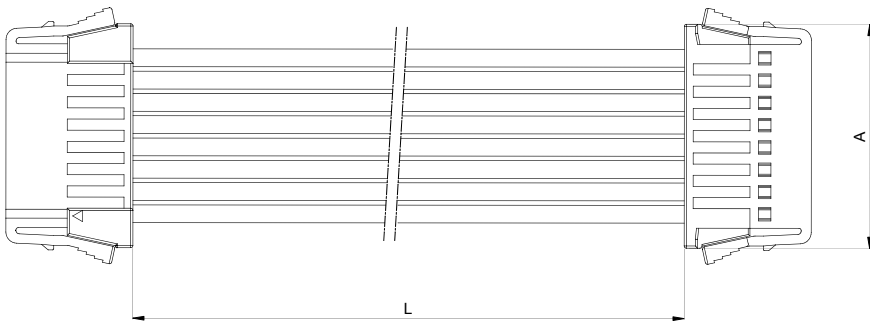

12	28.1
10	24.1
8	20.1
6	16.1
5	14.1
4	12.1
3	10.1
2	8.1
Position	Dim A

All dimensions in mm.

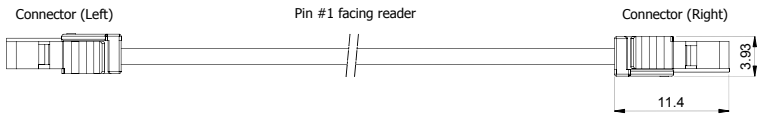



# iBridge and iBridge Ultra

## iBridge - FEMALE CABLE ASSEMBLIES

### ORDERING INFORMATION

No. of Pins	Cable Type	Mating Cycles	Cable Size	Length (mm)	Part Number
2	PVC	30 min.	AWG 22	100	109948
2	PVC	30 min.	AWG 22	200	109949
2	PVC	30 min.	AWG 22	300	109950
2	PVC	30 min.	AWG 24	100	109951
2	PVC	30 min.	AWG 24	200	109952
2	PVC	30 min.	AWG 24	300	109953
3	PVC	30 min.	AWG 22	100	109954
3	PVC	30 min.	AWG 22	200	109955
3	PVC	30 min.	AWG 22	300	109956
3	PVC	30 min.	AWG 24	100	109957
3	PVC	30 min.	AWG 24	200	109958
3	PVC	30 min.	AWG 24	300	109959
4	PVC	30 min.	AWG 22	100	109960
4	PVC	30 min.	AWG 22	200	109961
4	PVC	30 min.	AWG 22	300	109962
4	PVC	30 min.	AWG 24	100	109963
4	PVC	30 min.	AWG 24	200	109964
4	PVC	30 min.	AWG 24	300	109965

# iBridge and iBridge Ultra

## iBridge - FEMALE CABLE ASSEMBLIES

### ORDERING INFORMATION

No. of Pins	Cable Type	Mating Cycles	Cable Size	Length (mm)	Part Number
5	PVC	30 min.	AWG 22	100	109966
5	PVC	30 min.	AWG 22	200	109967
5	PVC	30 min.	AWG 22	300	109968
5	PVC	30 min.	AWG 24	100	109969
5	PVC	30 min.	AWG 24	200	109970
5	PVC	30 min.	AWG 24	300	109971
6	PVC	30 min.	AWG 22	100	109972
6	PVC	30 min.	AWG 22	200	109973
6	PVC	30 min.	AWG 22	300	109974
6	PVC	30 min.	AWG 24	100	109975
6	PVC	30 min.	AWG 24	200	109976
6	PVC	30 min.	AWG 24	300	109977
8	PVC	30 min.	AWG 22	100	109978
8	PVC	30 min.	AWG 22	200	109979
8	PVC	30 min.	AWG 22	300	109980
8	PVC	30 min.	AWG 24	100	109981
8	PVC	30 min.	AWG 24	200	109982
8	PVC	30 min.	AWG 24	300	109983

# iBridge and iBridge Ultra

## iBridge - FEMALE CABLE ASSEMBLIES

### ORDERING INFORMATION

No. of Pins	Cable Type	Mating Cycles	Cable Size	Length (mm)	Part Number
10	PVC	30 min.	AWG 22	100	119870
10	PVC	30 min.	AWG 22	200	119871
10	PVC	30 min.	AWG 22	300	119872
10	PVC	30 min.	AWG 24	100	119873
10	PVC	30 min.	AWG 24	200	119874
10	PVC	30 min.	AWG 24	300	119875
12	PVC	30 min.	AWG 22	100	119876
12	PVC	30 min.	AWG 22	200	119877
12	PVC	30 min.	AWG 22	300	119878
12	PVC	30 min.	AWG 24	100	119879
12	PVC	30 min.	AWG 24	200	119880
12	PVC	30 min.	AWG 24	300	119881

# iBridge and iBridge Ultra

## iBridge - FEMALE CABLE ASSEMBLIES

### ORDER FORM

(Please fill in the blank / choose your options)

Pin Count: \_\_\_\_\_  
2, 3, 4, 5, 6, 8, 10, 12

Plating / Performance:  Standard: Tin (min. 30 mating cycles)  
 Non-standard: Au (min. 100 mating cycles)

Cable Size:  AWG 22  
 AWG 24

Cable Type:  PVC (Standard)  
 High Temperature & Halogen-Free (Upon Request)

Cable Configuration:  Single-Ended (Only One Side with Connector)  
 Double-Ended (Both Sides with Connector)

Cable Length: \_\_\_\_\_ mm

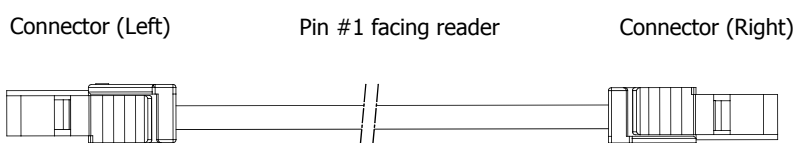

Requestor Name: \_\_\_\_\_

Company Name: \_\_\_\_\_

Project Name: \_\_\_\_\_

Quantity Required: \_\_\_\_\_ pcs

Estimated Annual Usage: \_\_\_\_\_ pcs

Request Date: \_\_\_\_\_

# iBridge and iBridge Ultra

## iBridge Ultra - FEMALE CABLE CONNECTOR

### DIMENSIONAL DRAWINGS

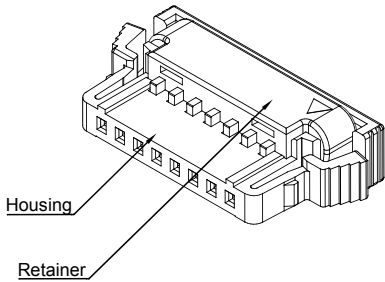

12	22.00	31.1
10	18.00	27.1
8	14.00	23.1
6	10.00	19.1
5	8.00	17.1
4	6.00	15.1
3	4.00	13.1
2	2.00	11.1
Position	Dim A	Dim B

All dimensions in mm.

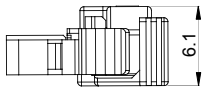
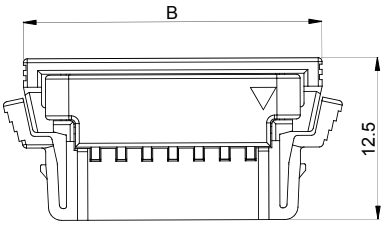
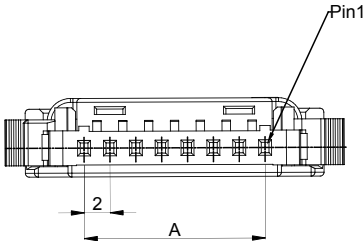

Retainer pre- loaded

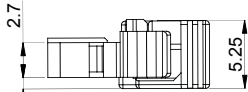

Retainer fully loaded

# iBridge and iBridge Ultra

## iBridge Ultra - FEMALE CABLE CONNECTOR

### ORDERING INFORMATION

No. of Pins	Termination	Packaging	Part Number
2	Crimp	Tray/ 154 pcs	119910
3	Crimp	Tray/ 133 pcs	119911
4	Crimp	Tray/ 119 pcs	119912
5	Crimp	Tray/ 105 pcs	119913
6	Crimp	Tray/ 98 pcs	119914
8	Crimp	Tray/ 84 pcs	119915
10	Crimp	Tray/ 70 pcs	119916
12	Crimp	Tray/ 63 pcs	119917

Contacts	Cable Type	Termination	Packaging	Part Number
Female Contact	AWG 22, 24	Crimp	Reel/ 500 pcs	119946
Female Contact	AWG 22, 24	Crimp	Reel/ 10000 pcs	119945

Tool	Cable Type	Packaging	Part Number
Hand Crimp	AWG 22, 24	1 pcs	335003

Hand crimp tool set consists of upper and lower tool.

# iBridge and iBridge Ultra

## iBridge Ultra - FEMALE CABLE ASSEMBLIES

### DIMENSIONAL DRAWINGS

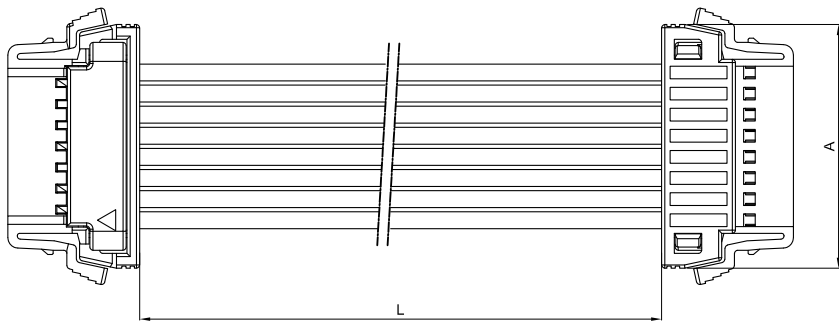

12	31.1
10	27.1
8	23.1
6	19.1
5	17.1
4	15.1
3	13.1
2	11.1
Position	Dim A

All dimensions in mm.

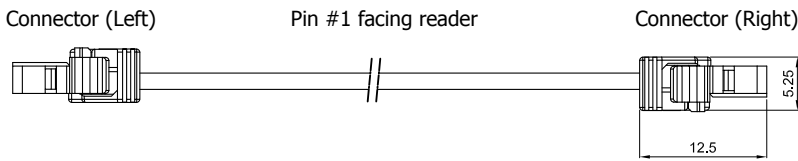

# iBridge and iBridge Ultra

## iBridge Ultra - FEMALE CABLE ASSEMBLIES

### ORDERING INFORMATION

No. of Pins	Cable Type	Mating Cycles	Cable Size	Length (mm)	Part Number
2	PVC	30 min.	AWG 22	100	119821
2	PVC	30 min.	AWG 22	200	119822
2	PVC	30 min.	AWG 22	300	119823
2	PVC	30 min.	AWG 24	100	119824
2	PVC	30 min.	AWG 24	200	119825
2	PVC	30 min.	AWG 24	300	119826
3	PVC	30 min.	AWG 22	100	119827
3	PVC	30 min.	AWG 22	200	119828
3	PVC	30 min.	AWG 22	300	119829
3	PVC	30 min.	AWG 24	100	119830
3	PVC	30 min.	AWG 24	200	119831
3	PVC	30 min.	AWG 24	300	119832
4	PVC	30 min.	AWG 22	100	119833
4	PVC	30 min.	AWG 22	200	119834
4	PVC	30 min.	AWG 22	300	119835
4	PVC	30 min.	AWG 24	100	119836
4	PVC	30 min.	AWG 24	200	119837
4	PVC	30 min.	AWG 24	300	119838



# iBridge and iBridge Ultra

## iBridge Ultra - FEMALE CABLE ASSEMBLIES

### ORDERING INFORMATION

No. of Pins	Cable Type	Mating Cycles	Cable Size	Length (mm)	Part Number
5	PVC	30 min.	AWG 22	100	119839
5	PVC	30 min.	AWG 22	200	119840
5	PVC	30 min.	AWG 22	300	119841
5	PVC	30 min.	AWG 24	100	119842
5	PVC	30 min.	AWG 24	200	119843
5	PVC	30 min.	AWG 24	300	119844
6	PVC	30 min.	AWG 22	100	119845
6	PVC	30 min.	AWG 22	200	119846
6	PVC	30 min.	AWG 22	300	119847
6	PVC	30 min.	AWG 24	100	119848
6	PVC	30 min.	AWG 24	200	119849
6	PVC	30 min.	AWG 24	300	119850
8	PVC	30 min.	AWG 22	100	119851
8	PVC	30 min.	AWG 22	200	119852
8	PVC	30 min.	AWG 22	300	119853
8	PVC	30 min.	AWG 24	100	119854
8	PVC	30 min.	AWG 24	200	119855
8	PVC	30 min.	AWG 24	300	119856

# iBridge and iBridge Ultra

## iBridge Ultra - FEMALE CABLE ASSEMBLIES

### ORDERING INFORMATION

No. of Pins	Cable Type	Mating Cycles	Cable Size	Length (mm)	Part Number
10	PVC	30 min.	AWG 22	100	119857
10	PVC	30 min.	AWG 22	200	119858
10	PVC	30 min.	AWG 22	300	119859
10	PVC	30 min.	AWG 24	100	119860
10	PVC	30 min.	AWG 24	200	119861
10	PVC	30 min.	AWG 24	300	119862
12	PVC	30 min.	AWG 22	100	119863
12	PVC	30 min.	AWG 22	200	119864
12	PVC	30 min.	AWG 22	300	119865
12	PVC	30 min.	AWG 24	100	119866
12	PVC	30 min.	AWG 24	200	119867
12	PVC	30 min.	AWG 24	300	119868

# iBridge and iBridge Ultra

## iBridge Ultra - FEMALE CABLE ASSEMBLIES



### ORDER FORM

(Please fill in the blank / choose your options)

Pin Count: \_\_\_\_\_  
2, 3, 4, 5, 6, 8, 10, 12

Plating / Performance:  Standard: Tin (min. 30 mating cycles)  
 Non-standard: Au (min. 100 mating cycles)

Cable Size:  AWG 22  
 AWG 24

Cable Type:  PVC (Standard)  
 High Temperature & Halogen-Free (Upon Request)

Cable Configuration:  Single-Ended (Only One Side with Connector)  
 Double-Ended (Both Sides with Connector)

Cable Length: \_\_\_\_\_ mm

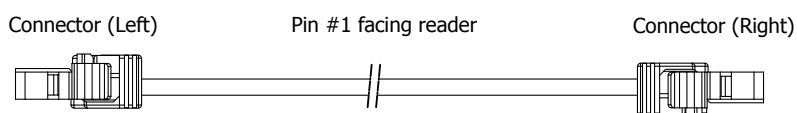

Requestor Name: \_\_\_\_\_

Company Name: \_\_\_\_\_

Project Name: \_\_\_\_\_

Quantity Required: \_\_\_\_\_ pcs

Estimated Annual Usage: \_\_\_\_\_ pcs

Request Date: \_\_\_\_\_



# iBridge and iBridge Ultra

## PART NUMBER INDEX —

Part Number	Page
109901	15
109902	15
109903	15
109904	15
109905	15
109906	15
109907	15
109908	15
109909	15
109910	15
109911	15
109912	15
109914	19
109915	19
109916	19
109917	19
109918	19
109919	19
109920	19
109921	19
109922	19
109923	19
109924	19
109925	19
109934	17
109935	17

Part Number	Page
109936	17
109937	17
109938	17
109939	17
109941	21
109942	21
109943	21
109944	21
109945	21
109946	21
109948	25
109949	25
109950	25
109951	25
109952	25
109953	25
109954	25
109955	25
109956	25
109957	25
109958	25
109959	25
109960	25
109961	25
109962	25
109963	25



# iBridge and iBridge Ultra

## PART NUMBER INDEX —

Part Number	Page
109964	25
109965	25
109966	26
109967	26
109968	26
109969	26
109970	26
109971	26
109972	26
109973	26
109974	26
109975	26
109976	26
109977	26
109978	26
109979	26
109980	26
109981	26
109982	26
109983	26
119821	32
119822	32
119823	32
119824	32
119825	32
119826	32

Part Number	Page
119827	32
119828	32
119829	32
119830	32
119831	32
119832	32
119833	32
119834	32
119835	32
119836	32
119837	32
119838	32
119839	33
119840	33
119841	33
119842	33
119843	33
119844	33
119845	33
119846	33
119847	33
119848	33
119849	33
119850	33
119851	33
119852	33



# iBridge and iBridge Ultra

## PART NUMBER INDEX —

Part Number	Page
119853	33
119854	33
119855	33
119856	33
119857	34
119858	34
119859	34
119860	34
119861	34
119862	34
119863	34
119864	34
119865	34
119866	34
119867	34
119868	34
119870	27
119871	27
119872	27
119873	27
119874	27
119875	27
119876	27
119877	27
119878	27
119879	27

Part Number	Page
119880	27
119881	27
119903	19
119908	19
119910	30
119911	30
119912	30
119913	30
119914	30
119915	30
119916	30
119917	30
119927	15
119928	15
119929	15
119930	15
119932	19
119933	19
119935	17
119936	17
119938	21
119939	21
119945	23, 30
119946	23, 30
119949	23
119950	23



# iBridge and iBridge Ultra

## PART NUMBER INDEX —

Part Number	Page
119951	23
119952	23
119953	23
119954	23
119955	23
119956	23
335003	23, 30

**ERNI Electronics GmbH & Co. KG**

Seestrasse 9  
73099 Adelberg  
Germany  
Tel +49 7166 50-0  
Fax +49 7166 50-282  
info@erni.com  
www.erni.com

**Europe South America Africa**

**ERNI Electronics, Inc.**

2201 Westwood Ave  
Richmond, VA 23230/USA  
Tel +1 804 228-4100  
Fax +1 804 228-4099  
info@erni.us

**North America Canada Mexico**

**ERNI Asia Holding Pte Ltd.**

Blk 4008 Ang Mo Kio Avenue 10  
#04-01/02 Techplace I  
Singapore 569625  
Tel +65 6555 5885  
Fax +65 6555 5995  
info@erni-asia.com

**Asia Australia New Zealand**

© ERNI Electronics GmbH & Co. KG 2016 • Printed in Germany • A policy of continuous improvement is followed and the right to alter any published data without notice is reserved.

ERNI®, ERNI WoR&D®, Act. Connect. Perfect®, MicroCon®, MicroStac®, MicroSpeed®, MiniBridge®, MiniMez®, MaxiBridge®, ERmet®, ERmet ZD®, ERmet ZDplus®, ERmet ZD HD®, ERbic®, ERNIPRESS®, INTERact® and BLUEcontact® are trademarks (registered or applied for in various countries) of ERNI Electronics GmbH & Co. KG.