

HE2B Enabling Switch

Multi-contact 3-position enabling switches Ideal for installing in large teach pendants

- Ergonomically-designed OFF-ON-OFF operation.
- Easy recognition of position 1 to 2 transition is made possible by a snap action switch.
- Sufficient difference in operating force is provided for shifting from position 2 to 3.
- Low pressure is required to maintain position 2, allowing for longtime operation.
- Reliable operation is assured even when the edge of the operator button is pressed.
- The switch does not turn ON while being released from position 3 (OFF) to position 1 (OFF) (IEC60204-1, 9.2.5.8).
- Some teach pendants are equipped with two 3-position enabling switches, and when one switch is pressed to position 3 (OFF), the other switch must not enable machine operation even when pressed to position 2. Enabling of machine operation must resume after both switches are released. For this purpose, also available are 3-position enabling switches with monitoring switches for button returned to position 1 and button pressed to position 3 (monitor switches have direct opening action mechanism).
- Two contacts are provided in a 3-position enabling switch so that even if one contact fails due to welding or short-circuit, the other contact can disable machine operation.
- The waterproof rubber boot provides IP65 protection.

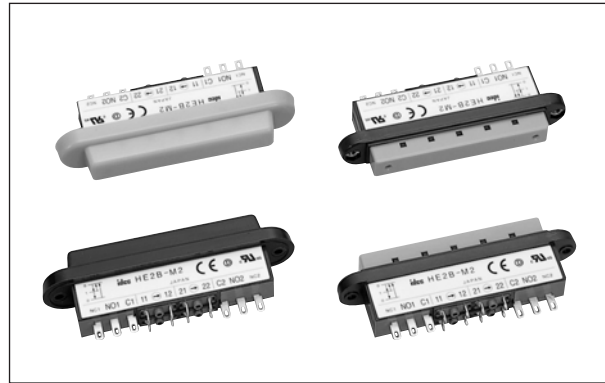

Types

Type	Contact Configuration			Type No.	Ordering Type No.	Package Quantity	
	3-position Switch	Button Return Monitor Switch	Button Depress Monitor Switch				
Without Rubber Boot	2	0	0	HE2B-M200	HE2B-M200 HE2B-M200PN10	1 10	
	2	1	1	HE2B-M211	HE2B-M211 HE2B-M211PN10	1 10	
	2	2	2	HE2B-M222	HE2B-M222 HE2B-M222PN10	1 10	
With Rubber Boot	Rubber Boot Material: Silicon Rubber Color: Y: yellow B: black	2	0	0	HE2B-M200P*	HE2B-M200P* HE2B-M200P*PN10	1 10
		2	1	1	HE2B-M211P*	HE2B-M211P* HE2B-M211P*PN10	1 10
		2	2	2	HE2B-M222P*	HE2B-M222P* HE2B-M222P*PN10	1 10
	Rubber Boot Material: NBR/PVC Polyblend Color: gray	2	0	0	HE2B-M200PN1	HE2B-M200PN1 HE2B-M200PN1PN10	1 10
		2	1	1	HE2B-M211PN1	HE2B-M211PN1 HE2B-M211PN1PN10	1 10
		2	2	2	HE2B-M222PN1	HE2B-M222PN1 HE2B-M222PN1PN10	1 10
		2	2	2	HE2B-M222PN1	HE2B-M222PN1PN10	10

Note: Specify rubber boot color code in place of * in the Type No.

• Type No. Development

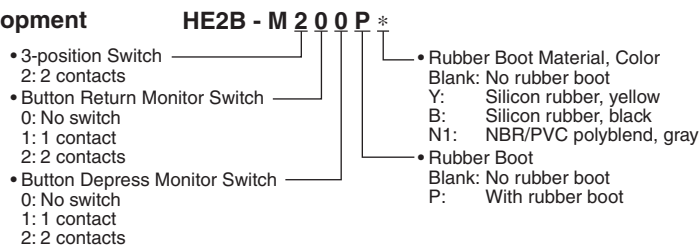

Ratings

• Contact Ratings

Rated Insulation Voltage (Ui)				250V		
Rated Thermal Current (Ith)				3A		
Rated Voltage (Ue)				30V	125V	250V
Rated Current (Ie)	3-position Switch	AC	Resistive Load (AC-12)	—	1A	0.5A
			Inductive Load (AC-15)	—	0.7A	0.5A
		DC	Resistive Load (DC-12)	1A	0.2A	—
	Inductive Load (DC-13)	0.7A	0.1A	—		
	Button Return Monitor Switch Button Depress Monitor Switch	AC	Resistive Load (AC-12)	—	2A	1A
			Inductive Load (AC-15)	—	1A	0.5A
DC		Resistive Load (DC-12)	2A	0.4A	0.2A	
Inductive Load (DC-13)	1A	0.22A	0.1A			
Contact Configuration		3-position Switch	2 contacts			
		Button Return Monitor Switch	0 to 2 contacts			
		Button Depress Monitor Switch	0 to 2 contacts			

• Minimum applicable load (reference value): 3V AC/DC, 5 mA

HE2B Enabling Switch

Specifications

Applicable Standards	IEC 60947-5-1, EN60947-5-1 (DEMKO approval), UL508 (UL recognized) CSA C22.2, No. 14 (c-UL recognized), JIS C8201-5-1
Applicable Standards for Use	ISO 12100 / EN 292, IEC 60204-1 / EN 60204-1 ISO11161 / prEN 11161, ISO10218 / EN 775, ANSI / RIA R15.06, ANSI B11.19
Operating Temperature	-25 to +60°C (no freezing) (without rubber boot, with silicon rubber boot) -10 to +60°C (no freezing) (with NBR/PVC polyblend rubber boot)
Relative Humidity	45 to 85% RH (no condensation)
Storage Temperature	-40 to +80°C (no freezing)
Pollution Degree	2 (inside panel, terminal side) 3 (outside panel, operator side)
Contact Resistance	50 mΩ maximum (initial value)
Insulation Resistance	Between live and dead metal parts: 100 MΩ minimum (500V DC megger) Between terminals of different poles: 100 MΩ minimum (500V DC megger)
Impulse Withstand Voltage	2.5 kV
Operating Frequency	1,200 operations per hour
Mechanical Durability	Position 1 → 2 → 1: 1,000,000 operations minimum Position 1 → 2 → 3 → 1: 100,000 operations minimum
Electrical Durability	100,000 operations minimum
Shock Resistance	Operating extremes: 150 m/s ² Damage limits: 1,000 m/s ²
Vibration Resistance	Operating extremes: 5 to 55 Hz, amplitude 0.5 mm Damage limits: 16.7 Hz, amplitude 1.5 mm
Terminal Style	Solder terminal
Applicable Wire	1 cable, 0.5 mm ² maximum
Solder Terminal Heat Resistance	310 to 350 °C, 3 seconds maximum
Terminal Tensile Strength	20N minimum
Mounting Screw Recommended Tightening Torque	0.5 to 0.8 N·m
Degree of Protection	IP40 (without rubber boot) IP65 (with rubber boot)
Conditional Short-circuit Current	50A (250V) (Use 250V/10A fast acting type fuse for short-circuit protection.)
Direct Opening Force	60N minimum (button return monitor and button depress monitor switches)
Operator Strength	500N minimum (when pressing the entire button surface)
Weight (approx.)	26g (without rubber boot) 30g (with rubber boot)

Operation Characteristics

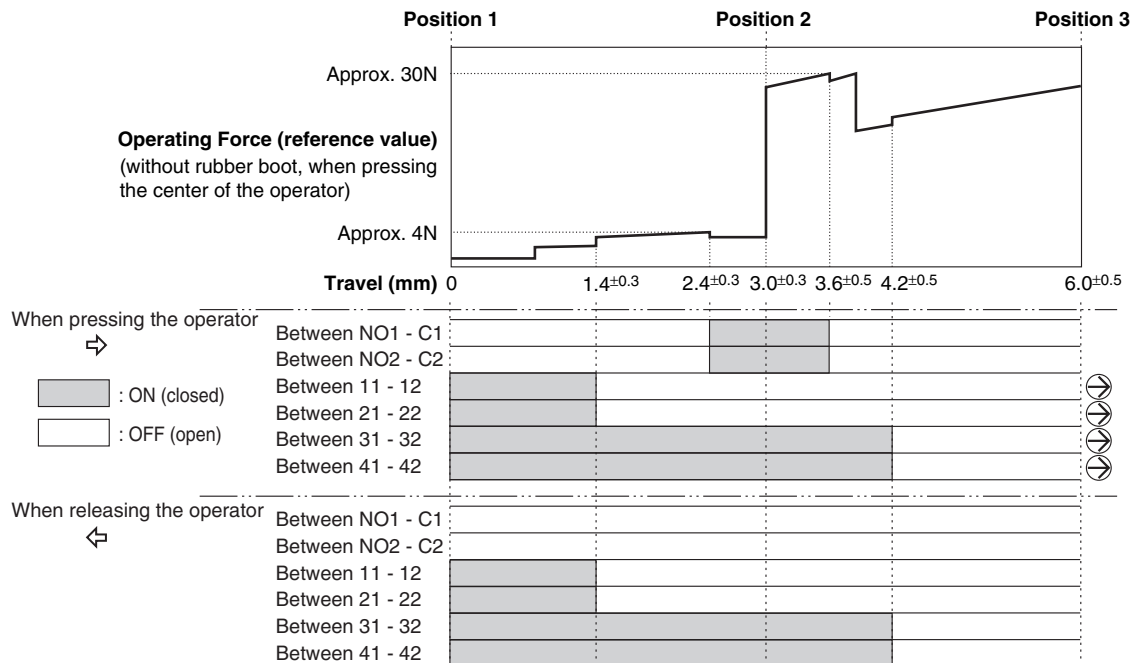

Notes:

- When a rubber boot is used, the operating force depends on the operating temperature.
- The operating force to shift the switch from position 2 to position 3 can be changed. For details, contact IDEC.

HE2B Enabling Switch

Terminal Arrangement (Bottom View)

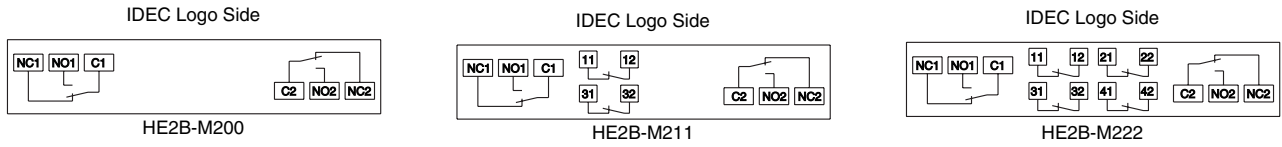

- 3-position switch (note): 2 contacts, terminal nos. between NO1 – C1, NO2 – C2
 - Button return monitor switch: 0 to 2 contacts, terminal nos. between 11 – 12, 21 – 22
 - Button depress monitor switch: 0 to 2 contacts, terminal nos. between 31 – 32, 41 – 42
- Note: Use NO and C terminals for OFF → ON → OFF 3-position switch (NC terminal is not used).

Dimensions

• Without Rubber Boot

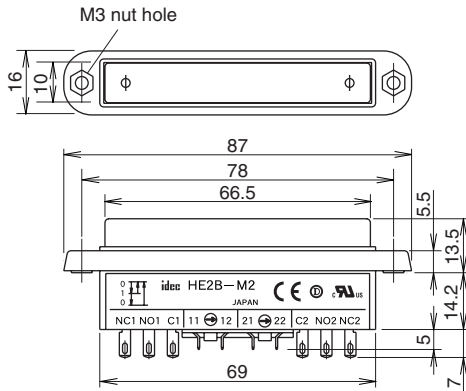

• With Rubber Boot

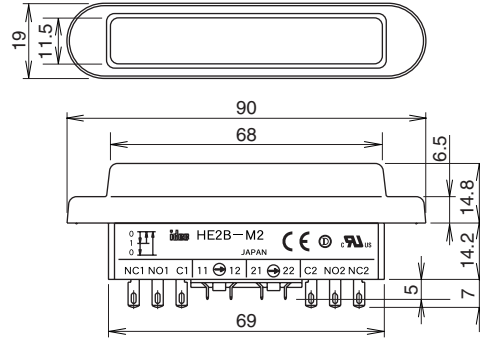

- M3 nuts are supplied with the HE2B enabling switch.

Mounting Hole Layout

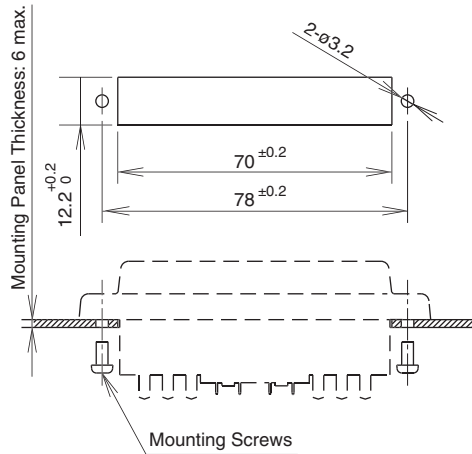

- Mounting screw: Two M3 screws
- Length of mounting screw: The thickness of mounting panel + 4 to 5 mm

All dimensions in mm.

Accessories

• Replacement Rubber Boot

Material	Color	Type No.	Ordering Type No.	Package Quantity
Silicon Rubber	Y: yellow	HE9Z-D2*	HE9Z-D2*PN10	10
	B: black			
NBR/PVC Polyblend	Gray	HE9Z-D2N1	HE9Z-D2N1PN10	

Note: Specify a rubber boot color code in place of * in the Type No.

