

RECOMMENDED MATING P.C BOARD CONFIGURATION

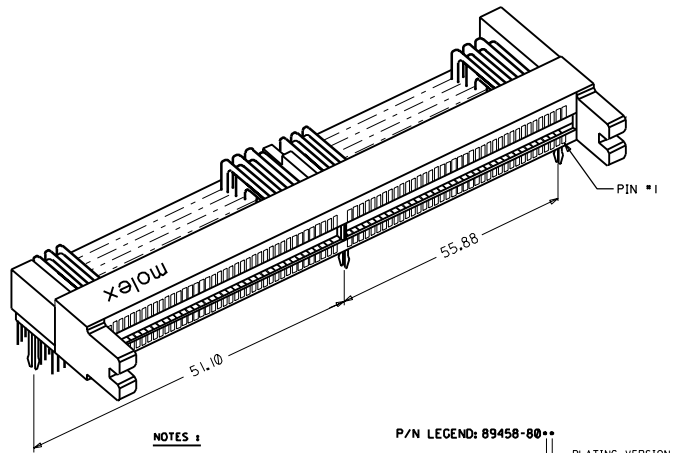

- NOTES :**
 HOUSING - PPS , COLOR : BROWN.
 TERMINAL - PHOSPHOR BRONZE.
- FINISH :**
- 0 - GOLD FLASH IN CONTACT AREA, 1.52um/60uin MIN. TIN IN SOLDER TAIL, BOTH OVER 0.76um/30uin MIN. NICKEL OVERALL.
 - 1 - 0.25um/10uin MIN. GOLD IN CONTACT AREA, 1.52um/60uin MIN. TIN IN SOLDER TAIL, BOTH OVER 0.76um/30uin MIN. NICKEL OVERALL.
 - 2 - 0.38um/15uin MIN. GOLD IN CONTACT AREA, 1.52um/60uin MIN. TIN IN SOLDER TAIL, BOTH OVER 0.76um/30uin MIN. NICKEL OVERALL.
 - 3 - 0.76um/30uin MIN. GOLD IN CONTACT AREA, 1.52um/60uin MIN. TIN IN SOLDER TAIL, BOTH OVER 0.76um/30uin MIN. NICKEL OVERALL.
 - 4 - 0.50um/20uin MIN. GOLD IN CONTACT AREA, 1.52um/60uin MIN. TIN IN SOLDER TAIL, BOTH OVER 0.76um/30uin MIN. NICKEL OVERALL.
- P/N LEGEND: 89458-80****
- | | |
|---|-----------------|
| 0 | PLATING VERSION |
| 1 | |
| 2 | |
| 3 | |
| 4 | |

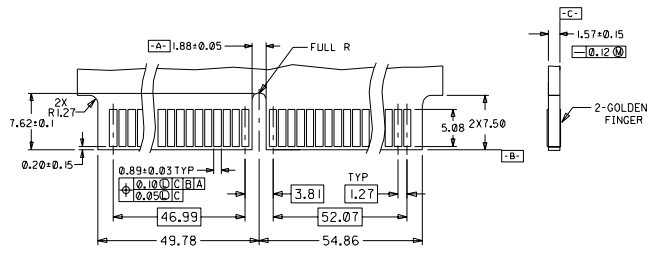

RECOMMENDED MATING PCB EDGE CONFIGURATION

				MATERIAL : REF. TO ABOVE		MOLEX TAIWAN LTD. SHEET 1 OF 1	
				FINISH : REF. TO ABOVE			
				WIRE RANGE : _____		GENERAL TOLERANCES ANGLE : ± 3° DIM : ± .25/∅.10	
				INS. RANGE : _____		ENG. NO.: SDA-89458-80**	
B	PER ECN T97-358	SANDRA970418		DRAWN BY SANDRA 381004		REV B	
AI	PER ECN T97-101	SANDRA960104		CHK'D BY		TITLE : LOW PROFILE HIGH END WALL EDGECARD CONN. (RIGHT ANGLE 160CKTS)	
LTR	REVISION RECORD	ECN	DR	DATE	APPR'D BY	SCALE	
REVISE ONLY ON CAD SYSTEM							