

### 19-951.2 - Lens

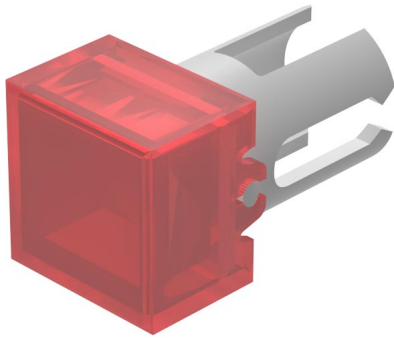

*Attention: The preview is based on a sample product. This can differ from your current configuration.*

### Mounting

Design raised

### Other Attributes

Weight 0,001 kg  
Dimension 7.3 x 7.3 mm  
Lens holder optical effect translucent

### Operating-/Indication part

Lens optics transparent  
Lens material Plastic  
Lens profile flat  
Lens colour red  
Lens illumination illuminative