

VHA6 Series 3.3V VCXO CMOS Oscillator

Sep 2017



- Pletronics' VHA6 Series is a voltage controlled crystal oscillator with a CMOS output.
- This model uses fundamental mode crystals with no multiplication circuits.
- Tape and Reel or tube packaging is available.
- 1.7 to 108 MHz
- 5x7 mm Ceramic LCC Package
- Voltage Control Function on pad 1
- Enable/ Disable Function on pad 2

**Pletronics Inc. certifies this device is in accordance with the
RoHS 6/6 (2011/65/EC) and WEEE (2002/96/EC) directives.**

Pletronics Inc. guarantees the device does not contain the following:

Cadmium, Hexavalent Chromium, Lead, Mercury, PBB's, PBDE's

Weight of the Device: 0.2 grams

Moisture Sensitivity Level: 1 As defined in J-STD-020C

Second Level Interconnect code: e4

Absolute Maximum Ratings:

Parameter	Unit
V _{CC} Supply Voltage	-0.5V to +5.5V
V _i Input Voltage	-0.5V to V _{CC} + 0.5V
V _o Output Voltage	-0.5V to V _{CC} + 0.5V

Thermal Characteristics

The maximum die or junction temperature is 155°C

The thermal resistance junction to board is 60 to 100°C/Watt depending on the solder pads, ground plane and construction of the PCB.

Part Number:

VHA6029036 E G 500 100 -16.384M -XX

	Packaging code or blank T250 = 250 per Tape and Reel T500 = 500 per Tape and Reel T1K = 1000 per Tape and Reel
	Nominal Frequency in MHz
	Pullability in ppm (Vcontrol) (value in ppm) 050 = ± 50 ppm minimum 100 = ± 100 ppm minimum (typical values shown)
	Stability in ppm (Stability in ppm * 10) 000 = APR 500 = ± 50 ppm 250 = ± 25 ppm (typical values shown)
	Highest Specified Operating Temperature A = +40°C F = +65°C L = +90°C B = +45°C G = +70°C M = +95°C C = +50°C H = +75°C N = +100°C D = +55°C J = +80°C P = +105°C E = +60°C K = +85°C
	Lowest Specified Operating Temperature A = +10°C E = -10°C J = -30°C B = +5°C F = -15°C K = -35°C C = +0°C G = -20°C L = -40°C D = -5°C H = -25°C M = -45°C
Series (Part Type, Logic & Package)	

Part Marking:

PLE VHA6 or VHYWWXX
 FF.FFFM FF.FFFM
 • YMDXX • PXXXXX

Legend:
 P or PLE = Pletronics
 FF.FFFM = Frequency in MHz
 YWW or YMD = Date of Manufacture (year and week, or year, month and day)

All other marking is internal factory codes

Specifications such as frequency stability, supply voltage and operating temperature range, etc. are not identified from the marking. External packaging labels and packing list will correctly identify the ordered Pletronics part number.

Codes for Date Code YMD

Code	3	4	5	6	7	8	9
Year	2013	2014	2015	2016	2017	2018	2019

Code	A	B	C	D	E	F	G	H	J	K	L	M
Month	JAN	FEB	MAR	APR	MAY	JUN	JUL	AUG	SEP	OCT	NOV	DEC

Code	1	2	3	4	5	6	7	8	9	A	B	C
Day	1	2	3	4	5	6	7	8	9	10	11	12
Code	D	E	F	G	H	J	K	L	M	N	P	R
Day	13	14	15	16	17	18	19	20	21	22	23	24
Code	T	U	V	W	X	Y	Z					
Day	25	26	27	28	29	30	31					

Electrical Specification for 3.30V $\pm 10\%$ over the specified temperature range

Item	Min	Typ	Max	Unit	Condition	
Frequency Range	1.7	-	108	MHz		
Frequency Accuracy ¹	-	-	± 25	ppm	Not specified if APR is specified	
Pullability ¹	25-55 MHz	± 90	-	± 125	ppm	For Vcontrol 1.65 V ± 1.65 V. Not specified if APR is specified Defined by the part number
	1.7-25 MHz	± 110	-	± 140	ppm	
Pullability ¹	25-55 MHz	± 50	-	-	ppm	Absolute Pull Range, includes the effect of temperature stability Defined by the part number
	APR 1.7-25 MHz	± 75	-	-	ppm	
Output Waveform	CMOS					
Output High Level	90	-	-	%	of V _{CC} for I _{OH} = +7 mA	
	70	-	-	%	of V _{CC} for I _{OH} = +14 mA	
Output Low Level	-	-	10	%	of V _{CC} for I _{OL} = -7 mA	
	-	-	30	%	of V _{CC} for I _{OL} = -14 mA	
Output T _{RISE} and T _{FALL}	-	4.0	6.0	nS	10% to 90% of V _{CC} , C _{LOAD} = 15 pF	
Output Symmetry	45	50	55	%	at 50% point of V _{CC} (See load circuit)	
Vcontrol Resistance Pin 1	20	25	-	Kohm		
Modulation Bandwidth	10	20	-	KHz	Vcontrol = 1.65V ± 1.65 V, -3dB	
E/D Internal Pull-up	50	-	-	Kohm	to V _{CC}	
V disable	-	-	15	%	of V _{CC} applied to pin 1	
V enable	85	-	-	%	of V _{CC} applied to pin 1	
Output leakage	V _{OUT} = V _{CC}	-10	-	+10	uA	Pin 1 low, device disabled
	V _{OUT} = 0V	-10	-	+10	uA	
Enable time	-	-	250	nS	Time for output to reach a logic state	
Disable time	-	-	250	nS	Time for output to reach a high Z state	
Start up time	-	1.5	10	mS	Time for output to reach specified frequency	
Supply Current	-	5.0	8.0	mA	C _{LOAD} = 15 pF	
Operating Temperature	-45		+105	°C	Defined by part number	
Storage Temperature Range	-55		+125	°C		

Specifications with Pad 2 E/D open circuit

¹For all supply voltages, load changes, aging for 1 year, shock, vibration and temperatures.

Typical phase noise plot for 5 oscillators at different output frequencies.

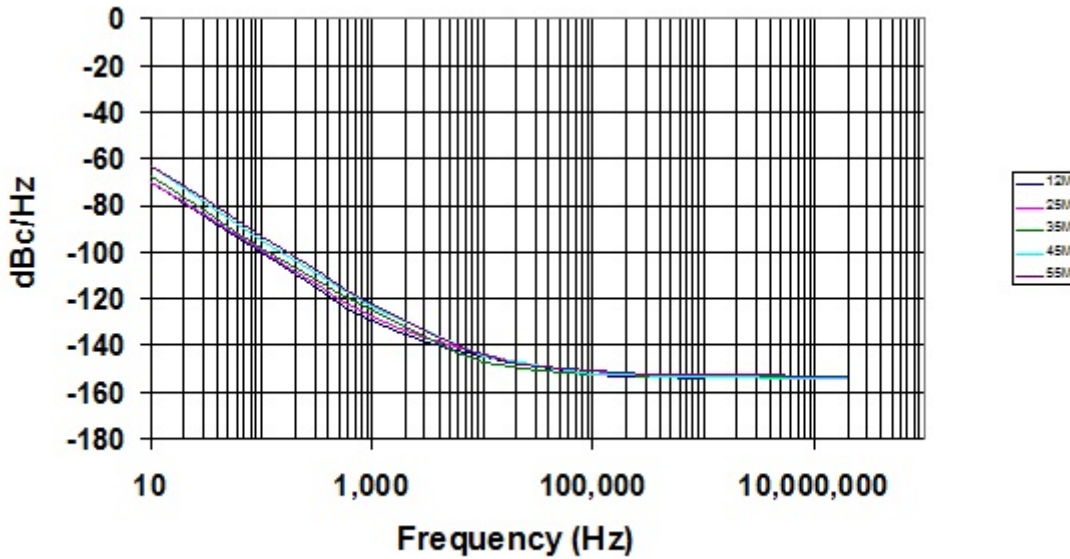

Load Circuit and Test Waveform

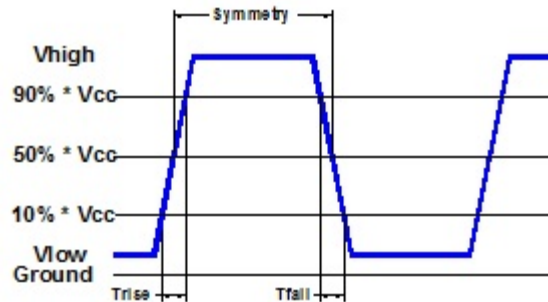
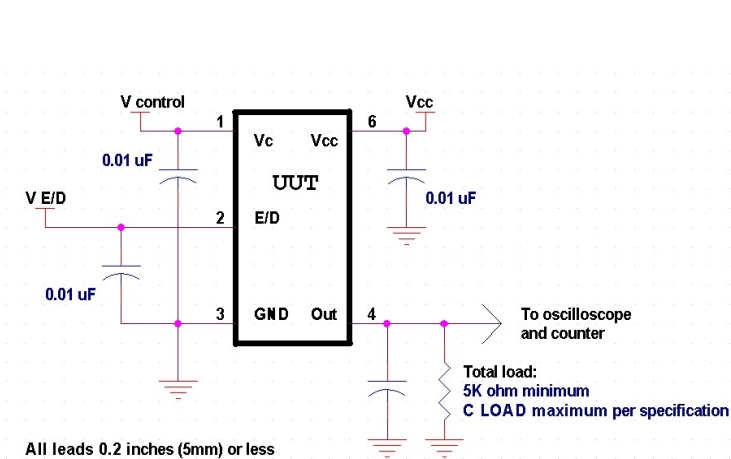

Reliability: Environmental Compliance

Parameter	Condition
Mechanical Shock	MIL-STD-883 Method 2002, Condition B
Vibration	MIL-STD-883 Method 2007, Condition A
Solderability	MIL-STD-883 Method 2003
Thermal Shock	MIL-STD-883 Method 1011, Condition A





ESD Rating

Model	Minimum Voltage	Conditions
Human Body Model	1500	MIL-STD-883 Method 3115
Charged Device Model	1000	JESD 22-C101

Package Labeling

Label is 1" x 2.6" (25.4mm x 66.7mm)
Font is Courier New
Bar code is 39-Full ASCII

Label is 1" x 2.6" (25.4mm x 66.7mm)
Font is Arial

P/N:  VHA6029036EG500100-16.384M
Customer P/N:  12345678
Qty:  1000 D/C  0510M012

RoHS Compliant 2nd Lvl Interconnect Category=e4 Max Safe Temp=260C for 10s 2X Max

Mechanical:

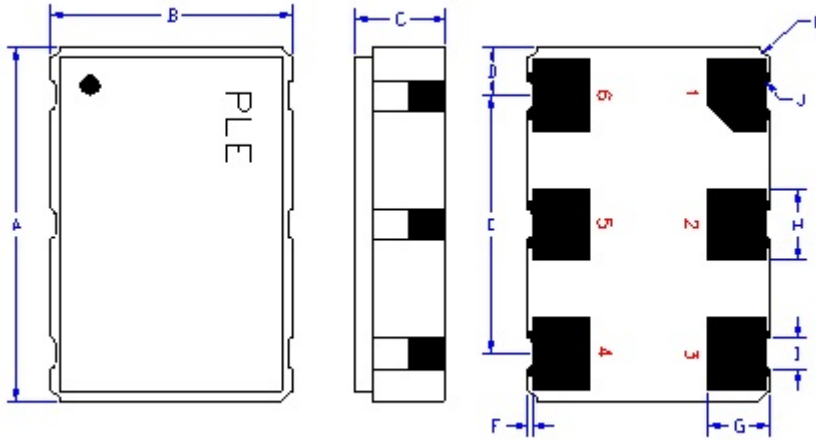

Gold 11.8 μ mches 0.3 μ m minimum over
Nickel 50 to 350 μ mches 1.27 to 8.89 μ m

Typical dimensions
Not to Scale

	Inches	mm
A	0.276 \pm 0.006	7.00 \pm 0.15
B	0.197 \pm 0.006	5.00 \pm 0.15
C	0.073 \pm 0.012	1.87 \pm 0.30
D ¹	0.038	0.96
E ¹	0.200	5.08
F ¹	0.004	0.10
G ¹	0.050	1.27
H ¹	0.055	1.40
I ¹	0.024	0.60
J ¹	0.004R	0.10R
K ¹	0.008R	0.20R

Pad	Function	Note
1	Vcontrol Input	
2	Output Enable/ Disable	When this pad is not connected, the oscillator shall operate When this pad is logic low, the output will be inhibited (high impedance state) Recommend connecting this pad to V _{cc} if the oscillator is to be always on
3	Ground (GND)	
4	Output	
5	N.C.	No Internal connection, pad may be connected to ground or V _{cc}
6	Supply Voltage (V _{cc})	Recommend connecting appropriate power supply bypass capacitors as close as possible.

Layout and application information



For Optimum Jitter Performance, Pletronics recommends:

- a ground plane under the device
- no large transient signals (both current and voltage) should be routed under the device do not layout near a large magnetic field such as a high frequency switching power supply
- do not place near piezoelectric buzzers or mechanical fans.

Reflow Cycle (typical for lead free processing)

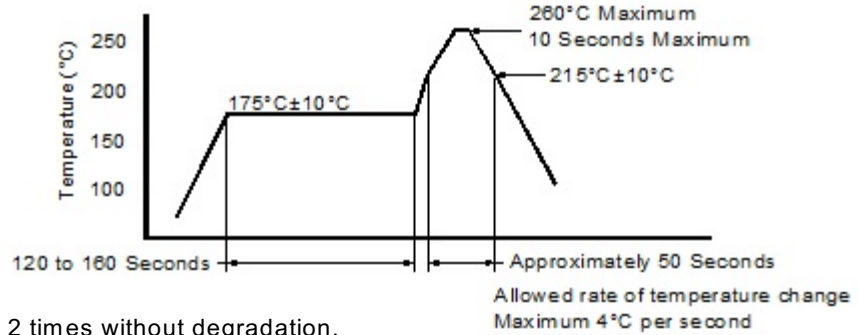

The part may be reflowed 2 times without degradation.

Tape and Reel: available for quantities of 250 to 1000 per reel

Constant Dimensions Table 1								
Tape Size	D0	D1 Min	E1	P0	P2	S1 Min	T Max	T1 Max
8mm	1.5	1.0	1.75	4.0	2.0 ±0.05	0.6	0.6	0.1
12mm		1.5			2.0 ±0.1			
16mm		+0.1 -0.0			1.5			
24mm		1.5			1.5			

Variable Dimensions Table 2							
Tape Size	B1 Max	E2 Min	F	P1	T2 Max	W Max	Ao, Bo & Ko
16 mm	12.1	14.25	7.5 ± 0.1	8.0 ± 0.1	8.0	16.3	Note 1

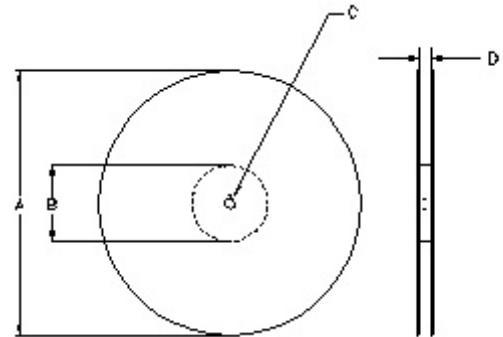

Note 1: Embossed cavity to conform to EIA-481-B Dimensions in mm Not to scale

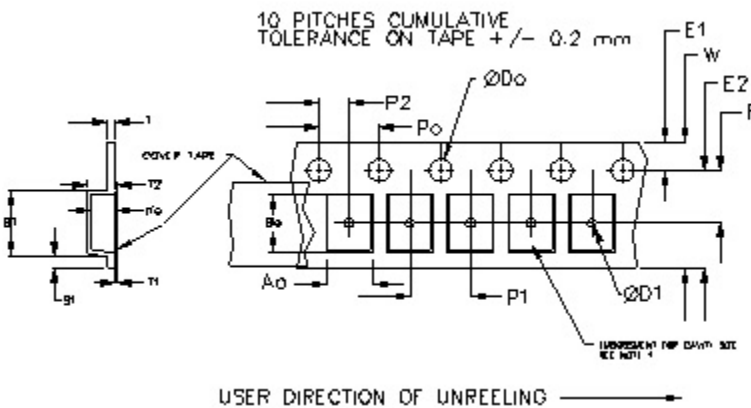

		REEL DIMENSIONS			
A	inches	7.0	10.0	13.0	Tape Width
	mm	177.8	254.0	330.2	
B	inches	2.50	4.00	3.75	Tape Width
	mm	63.5	101.6	95.3	
C	mm	13.0 +0.5 / -0.2			Tape Width
D	mm	16.4 +2.0 -0.0	16.4 +2.0 -0.0	16.4 +2.0 -0.0	

Reel dimensions may vary from the above

IMPORTANT NOTICE

Pletronics Incorporated (PLE) reserves the right to make corrections, improvements, modifications and other changes to this product at anytime. PLE reserves the right to discontinue any product or service without notice. Customers are responsible for obtaining the latest relevant information before placing orders and should verify that such information is current and complete. All products are sold subject to PLE's terms and conditions of sale supplied at the time of order acknowledgment.

PLE warrants performance of this product to the specifications applicable at the time of sale in accordance with PLE's limited warranty. Testing and other quality control techniques are used to the extent PLE deems necessary to support this warranty. Except where mandated by specific contractual documents, testing of all parameters of each product is not necessarily performed.

PLE assumes no liability for application assistance or customer product design. Customers are responsible for their products and applications using PLE components. To minimize the risks associated with the customer products and applications, customers should provide adequate design and operating safeguards.

PLE products are not designed, intended, authorized or warranted to be suitable for use in life support applications, weapons, weapon systems or space applications, devices or systems or other critical applications that may involve potential risks of death, personal injury or severe property or environmental damage. Inclusion of PLE products in such applications is understood to be fully at the risk of the customer. Use of PLE products in such applications requires the written approval of an appropriate PLE officer. Questions concerning potential risk applications should be directed to PLE.

PLE does not warrant or represent that any license, either express or implied, is granted under any PLE patent right, copyright, artwork or other intellectual property right relating to any combination, machine or process which PLE product or services are used. Information published by PLE regarding third-party products or services does not constitute a license from PLE to use such products or services or a warranty or endorsement thereof. Use of such information may require a license from a third party under the patents or other intellectual property of the third party, or a license from PLE under the patents or other intellectual property of PLE.

Reproduction of information in PLE data sheets or web site is permissible only if the reproduction is without alteration and is accompanied by associated warranties, conditions, limitations and notices. Reproduction of this information with alteration is an unfair and deceptive business practice. PLE is not responsible or liable for such altered documents.

Resale of PLE products or services with statements different from or beyond the parameters stated by PLE for that product or service voids all express and implied warranties for the associated PLE product or service and is an unfair or deceptive business practice. PLE is not responsible for any such statements.

Contacting Pletronics Inc.

Pletronics Inc.
19013 36th Ave. West
Lynnwood, WA 98036-5761 USA

Tel: 425-776-1880
Fax: 425-776-2760
E-mail: ple-sales@pletronics.com
URL: www.pletronics.com

Copyright © 2017 Pletronics Inc.