

4

3

2

1

THIS DRAWING IS UNPUBLISHED. RELEASED FOR PUBLICATION  
 © COPYRIGHT - By - ALL RIGHTS RESERVED.

LOC	DIST	REVISIONS			
P	LTR	DESCRIPTION	DATE	DWN	APVD
HM	00	G	REV, ECO-15-001353	28JAN2015	GG RA

SELF-TAPPING PAN HEAD SCREW  
 6-20 X 12.7 [.50]  
 QUANTITY 4

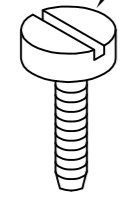

1 MATERIAL: ABS MOLDING COMPOUND, 94V-0 RATED, SEE TABLE FOR COLOR. SCREWS - ZINC PLATED CARBON STEEL.

2 ALL DIMENSIONS ARE MAXIMUM.

3 KIT SHIPPED NOT ASSEMBLED.

4 PACKAGED ONE KIT PER POLYBAG.

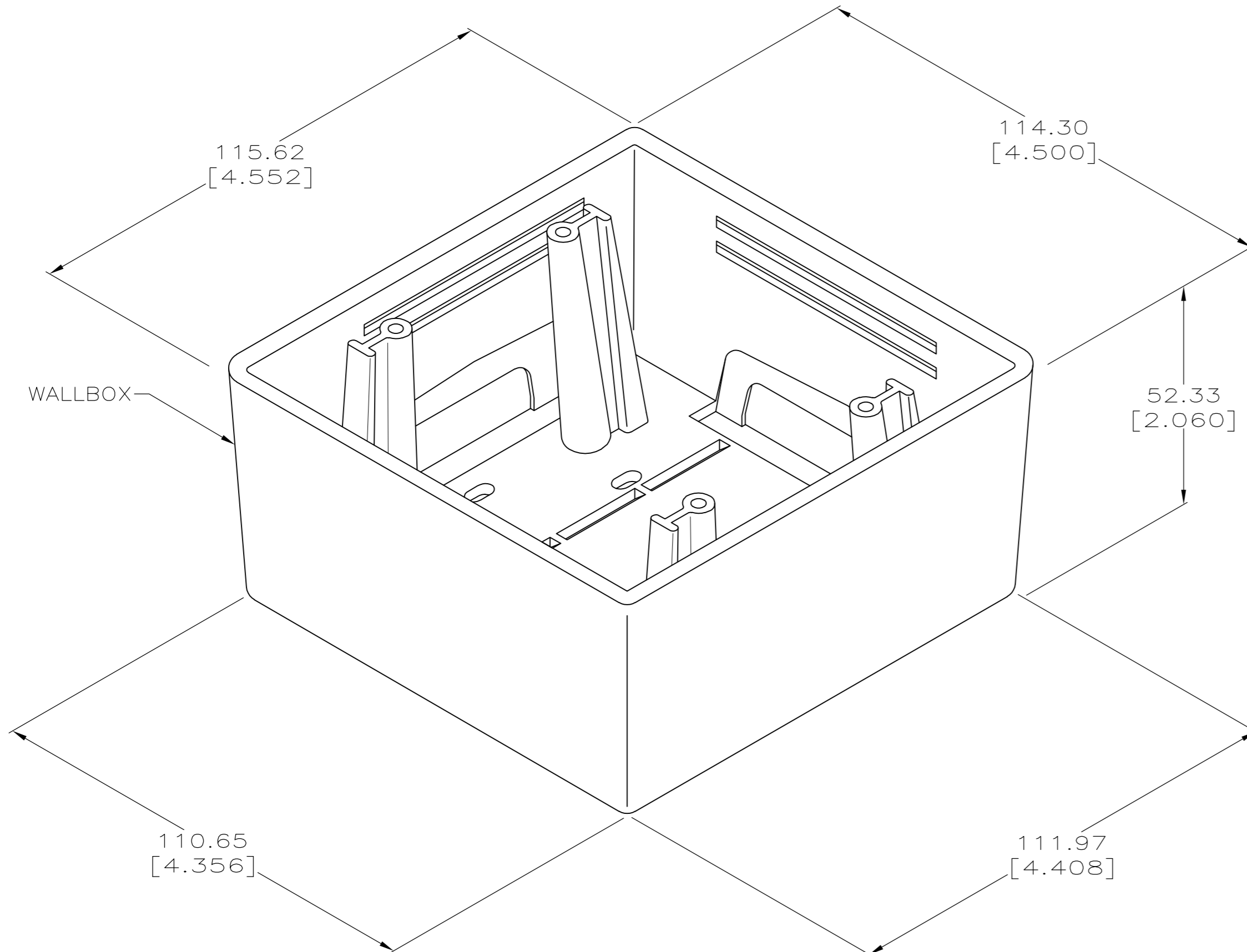

WALLBOX

115.62 [4.552]

114.30 [4.500]

52.33 [2.060]

110.65 [4.356]

111.97 [4.408]

**SUPERSEDED BY I-569499-I**

ALPINE WHITE	1-569499-3
ELECTRIC IVORY	1-569499-1
ELECTRIC IVORY	569499-5
NEMA GRAY	569499-4
WHITE	569499-3
BLACK	569499-2
LT ALMOND	569499-1
COLOR	PART NO.

THIS DRAWING IS A CONTROLLED DOCUMENT.		DWN	8-22-95	TE Connectivity	
DIMENSIONS: mm [INCHES]		DL DRUMMOND	8-30-95		
TOLERANCES UNLESS OTHERWISE SPECIFIED:		CHK	8-30-95		
0 PLC ± -		B. FOX			
1 PLC ± -		APVD	8-30-95		
2 PLC ± -		B. ANTHONY		NAME	
3 PLC ± -		PRODUCT SPEC		WALLBOX KIT, SURFACE, DUAL GANG	
4 PLC ± -		APPLICATION SPEC		SIZE	RESTRICTED TO
ANGLES ± -		WEIGHT		A2	
FINISH		CUSTOMER DRAWING		CAGE CODE	DRAWING NO
				00779	C=569499
				SCALE	SHEET
				1:1	1 of 1
				REV	G

1471-9 (3/11)

569499

A