

W34SF7C

### Features

- LOW POWER CONSUMPTION.
- POPULAR T-1 DIAMETER PACKAGE.
- GENERAL PURPOSE LEADS.
- RELIABLE AND RUGGED.
- LONG LIFE - SOLID STATE RELIABILITY.
- AVAILABLE ON TAPE AND REEL.

### Description

SF7 made with Gallium Aluminum Arsenide infrared  
Emitting diodes.

### Package Dimensions

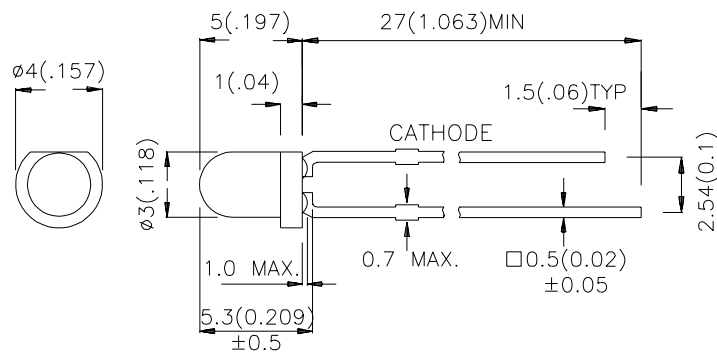

#### Notes:

1. All dimensions are in millimeters (inches).
2. Tolerance is  $\pm 0.25(0.01)$  unless otherwise noted.
3. Lead spacing is measured where the lead emerge package.
4. Specifications are subject to change without notice.

## Selection Guide

Part No.	Dice	Lens Type	Po(mW/sr) @ 20 mA *50mA		Viewing Angle
			Min.	Typ.	2θ1/2
W34SF7C	GaAlAs	WATER CLEAR	7	18	50°
			*10	*45	50°

Note:

1. θ1/2 is the angle from optical centerline where the luminous intensity is 1/2 the optical centerline value.

## Electrical / Optical Characteristics at T<sub>A</sub>=25°C

Parameter	P/N	Symbol	Typ.	Max.	Unit	Condition
Forward Voltage	SF7	V <sub>F</sub>	1.4	1.6	V	IF=20mA
Reverse Current	SF7	I <sub>R</sub>	-	10	μA	VR=5V
Junction Capacitance	SF7	C	30	-	pF	VF=0V, f=1MHz
Peak Spectral Wavelength	SF7	λ <sub>P</sub>	850	-	nm	IF=20mA
Spectral Bandwidth	SF7	Δλ 1/2	50	-	nm	IF=20mA

## Absolute Maximum Ratings at T<sub>A</sub>=25°C

Parameter	Symbol	SF7	Units
Power Dissipation	P <sub>T</sub>	100	mW
Forward Current	I <sub>F</sub>	50	mA
Peak Forward Current[1]	i <sub>FS</sub>	1	A
Reverse Voltage	V <sub>R</sub>	5	V
Operating Temperature	T <sub>A</sub>	-40~ +85	°C
Storage Temperature	T <sub>STG</sub>	-40~ +85	°C
Lead Solder Temperature[2]	260°C For 5 Seconds		

Notes:

1. 1/100 Duty Cycle, 10us Pulse Width.
2. 2mm below package base.

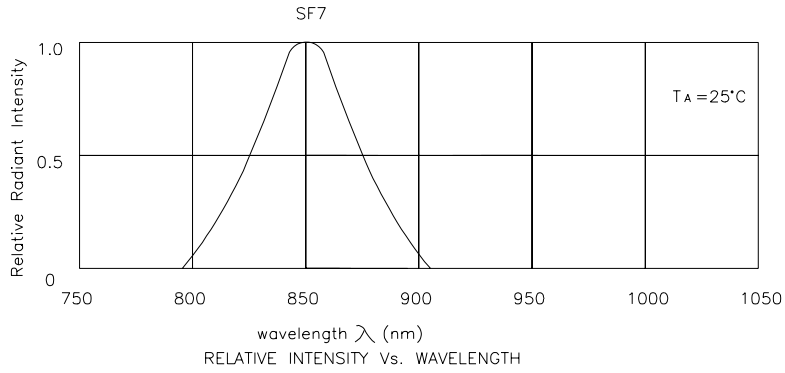

## W34SF7C

