

Ø 16mm

H6 Series

Miniature Switches & Pilot Lights







ø16

H6 series Miniature Switches & Pilot Lights

Designed to ensure ease of operation and safety
Ideal for heavy duty applications such as machine tools

- Removable contact block makes installation and removal easy.
- Large operators; bezel size (ø24 mm, 24×24 mm)
- High operating force and long stroke prevent inadvertent operation.
- Contact blocks can be removed when units are mounted collectively.
- Shock- and vibration-resistant rugged design
- UL recognized, CSA certified
- EN compliant (EN 60947-1, EN 60947-5-1, TÜV approved)

Applicable Standards	Mark	File No. or Organization
UL508		UL Recognition File No. E55996
CSA C22.2 No.14		CSA File No. LR 21451
EN60947-5-1		TÜV Rheinland
		EU Low Voltage Directive
GB14048.5		CCC No.2013010305591762



Contact Ratings

Gold Contact

Rated Insulation Voltage	250V	
Rated Thermal Current	3A	
Rated Operating Voltage	125V AC	30V DC
Rated Operating Current (resistive load)	0.1A	0.1A
Contact Material	Gold-clad silver	

Minimum applicable load (reference value): 5V AC/DC, 1 mA
 (Applicable range is subject to the operating condition and load.)

Silver Contact

Rated Insulation Voltage	250V				
Rated Thermal Current	5A				
Rated Operating Voltage	30V	125V	250V		
Rated Operating Current	AC 50/60 Hz	Resistive Load	—	3A	2A
		Inductive Load	—	2A	1.5A
	DC	Resistive Load	2A	0.4A	—
		Inductive Load	1A	0.2A	—
Contact Material	Silver				

AC inductive load: PF = 0.6 to 0.7, DC inductive load: L/R = 7 ms maximum

Built-in LED Lamp Ratings

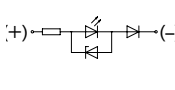
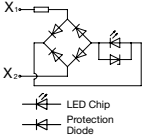



Rated Voltage	5V DC	6V AC/DC	12V AC/DC	24V AC/DC	
Operating Voltage	5V DC ±5%	6V AC/DC ±10%	12V AC/DC ±10%	24V AC/DC ±10%	
Part No.	LFTD-5②	LFTD-6②	LFTD-1②	LFTD-2②	
Lamp Base	SX6S/8×5.4				
Current Draw	A, G, PW, R, S, W,	A, R, W	G, PW, S	A, G, PW, R, S, W	
	AC	8mA	7mA	7mA	8mA
	DC	—	9mA	10mA	9mA
Lamp Base Color	Same as illumination color (PW: gray)				
Voltage Marking	Die stamped on the lamp base				
Life (reference value)	Approx. 50,000 hours (When used on complete DC at 25°C, luminance reduces to 50% of the initial intensity.)				
Internal Circuit	LFTD-5		LFTD-6/LFTD-1/LFTD-2		
					

- Specify a color code in place of ② in the Part No.
 A (amber), G (green), PW (pure white), R (red), S (blue), W (white)
- Use a PW (pure white) LED lamp for yellow illumination.

Specifications

Operating Temperature	-25 to +55°C (no freezing)	
Storage Temperature	-30 to +80°C	
Operating Humidity	45 to 85% RH (no condensation)	
Contact Resistance	50 mΩ maximum (initial value)	
Insulation Resistance	100 MΩ minimum (500V DC megger)	
Dielectric Strength	Switch Unit	Between live part and ground: 2,500V, 1 minute Between terminals of different poles: 2,500V, 1 minute Between terminals of the same pole: 1,000V, 1 minute
	Illumination Unit	Between live part and ground: 2,500V, 1 minute
Vibration Resistance	Operating extremes: 5 to 55 Hz, amplitude 0.5 mm	
Shock Resistance	Operating extremes: 100 m/s ² (10G) Damage limits: 1,000 m/s ² (100G)	
Mechanical Durability (minimum operations)	Momentary:	1,000,000
	Maintained:	200,000
	Selector switch:	250,000
	Key selector switch:	250,000
Electrical Durability (minimum operations)	Illuminated selector switch:	250,000
	Selector pushbutton:	250,000
Degree of Protection	IP65 (IEC 60529)	
Terminal Style	Solder/tab terminal #110 PC board terminal	
Weight (approx.)	HA1L-M1C24:	18g
	HA1P-1C04:	17g
	HA1P-14:	13g
	HA1B-M1C2:	16g
	HA1S-2C2:	18g
	HA1K-2C2A:	33g
HA1F-2C24:	20g	

HA1L/HA2L Illuminated Pushbuttons

Style	Operation	Contact Material	Operating Voltage	Contact	Part No.		② Illumination Color Code	
					Solder/Tab Terminal	PC Board Terminal		
Round HA1L   Marking plate size: ø18.4mm Engraving area: ø16.8mm (Depth: 0.5mm max.)	Momentary	Gold	5V DC ±5%	SPDT	HA1L-M1C11②	HA1L-M1C11V②	Specify a color code in place of ② in the Part No. A: amber G: green PW: pure white R: red S: blue W: white Y: yellow	
			12V AC/DC ±10%	DPDT	HA1L-M1C21②	HA1L-M1C21V②		
			24V AC/DC ±10%	SPDT	HA1L-M1C13②	HA1L-M1C13V②		
				DPDT	HA1L-M1C23②	HA1L-M1C23V②		
		Silver	5V DC ±5%	SPDT	HA1L-M1C51②	—		
			12V AC/DC ±10%	DPDT	HA1L-M1C61②			
			24V AC/DC ±10%	SPDT	HA1L-M1C53②			
				DPDT	HA1L-M1C63②			
	Maintained	Gold	5V DC ±5%	SPDT	HA1L-A1C11②			HA1L-A1C11V②
			12V AC/DC ±10%	DPDT	HA1L-A1C21②			HA1L-A1C21V②
			24V AC/DC ±10%	SPDT	HA1L-A1C13②			HA1L-A1C13V②
				DPDT	HA1L-A1C23②			HA1L-A1C23V②
		Silver	5V DC ±5%	SPDT	HA1L-A1C51②	—		
			12V AC/DC ±10%	DPDT	HA1L-A1C61②			
			24V AC/DC ±10%	SPDT	HA1L-A1C53②			
				DPDT	HA1L-A1C63②			
Square HA2L   Marking plate size: □18.4mm Engraving area: □16.4mm (Depth: 0.5mm max.)	Momentary	Gold	5V DC ±5%	SPDT	HA2L-M1C11②		HA2L-M1C11V②	
			12V AC/DC ±10%	DPDT	HA2L-M1C21②		HA2L-M1C21V②	
			24V AC/DC ±10%	SPDT	HA2L-M1C13②		HA2L-M1C13V②	
				DPDT	HA2L-M1C23②		HA2L-M1C23V②	
		Silver	5V DC ±5%	SPDT	HA2L-M1C51②	—		
			12V AC/DC ±10%	DPDT	HA2L-M1C61②			
			24V AC/DC ±10%	SPDT	HA2L-M1C53②			
				DPDT	HA2L-M1C63②			
	Maintained	Gold	5V DC ±5%	SPDT	HA2L-A1C11②		HA2L-A1C11V②	
			12V AC/DC ±10%	DPDT	HA2L-A1C21②		HA2L-A1C21V②	
			24V AC/DC ±10%	SPDT	HA2L-A1C13②		HA2L-A1C13V②	
				DPDT	HA2L-A1C23②		HA2L-A1C23V②	
		Silver	5V DC ±5%	SPDT	HA2L-A1C51②	—		
			12V AC/DC ±10%	DPDT	HA2L-A1C61②			
			24V AC/DC ±10%	SPDT	HA2L-A1C53②			
				DPDT	HA2L-A1C63②			

- See page 25 for marking plate size and engraving area.
 - One LED lamp is installed in an illuminated pushbutton.
 - White lens type (when light off) is available (not CCC approved). Clear lens is used instead of colored lens for amber, green, red, and blue illuminated pushbuttons. Amber, green, red, or blue LED units are used. To specify, insert W before ② in the part number.
- Example: HA1L-M1C24W②.

ø16 H6 Series Miniature Switches & Pilot Lights

HA3L/HA4L/HA1L-M3/A3 Illuminated Pushbuttons

Style	Operation	Contact Material	Operating Voltage	Contact	Part No.		② Illumination Color Code	
					Solder/Tab Terminal	PC Board Terminal		
Round w/Square Bezel HA3L  Marking plate size: ø18.4mm Engraving area: ø16.8mm (Depth: 0.5mm max.) 	Momentary	Gold	5V DC ±5%	SPDT	HA3L-M1C11②	HA3L-M1C11V②		
				DPDT	HA3L-M1C21②	HA3L-M1C21V②		
			12V AC/DC ±10%	SPDT	HA3L-M1C13②	HA3L-M1C13V②		
				DPDT	HA3L-M1C23②	HA3L-M1C23V②		
			24V AC/DC ±10%	SPDT	HA3L-M1C14②	HA3L-M1C14V②		
				DPDT	HA3L-M1C24②	HA3L-M1C24V②		
		Silver	5V DC ±5%	SPDT	HA3L-M1C51②	—		
				DPDT	HA3L-M1C61②			
			12V AC/DC ±10%	SPDT	HA3L-M1C53②			
				DPDT	HA3L-M1C63②			
			24V AC/DC ±10%	SPDT	HA3L-M1C54②			
				DPDT	HA3L-M1C64②			
	Maintained	Gold	5V DC ±5%	SPDT	HA3L-A1C11②			HA3L-A1C11V②
				DPDT	HA3L-A1C21②			HA3L-A1C21V②
			12V AC/DC ±10%	SPDT	HA3L-A1C13②			HA3L-A1C13V②
				DPDT	HA3L-A1C23②			HA3L-A1C23V②
			24V AC/DC ±10%	SPDT	HA3L-A1C14②			HA3L-A1C14V②
				DPDT	HA3L-A1C24②			HA3L-A1C24V②
		Silver	5V DC ±5%	SPDT	HA3L-A1C51②	—		
				DPDT	HA3L-A1C61②			
			12V AC/DC ±10%	SPDT	HA3L-A1C53②			
				DPDT	HA3L-A1C63②			
			24V AC/DC ±10%	SPDT	HA3L-A1C54②			
				DPDT	HA3L-A1C64②			
Square w/Four-sided Barrier HA4L  Marking plate size: □18.4mm Engraving area: □16.4mm (Depth: 0.5mm max.) 	Momentary	Gold	5V DC ±5%	SPDT	HA4L-M1C11②		HA4L-M1C11V②	
				DPDT	HA4L-M1C21②		HA4L-M1C21V②	
			12V AC/DC ±10%	SPDT	HA4L-M1C13②		HA4L-M1C13V②	
				DPDT	HA4L-M1C23②		HA4L-M1C23V②	
			24V AC/DC ±10%	SPDT	HA4L-M1C14②		HA4L-M1C14V②	
				DPDT	HA4L-M1C24②		HA4L-M1C24V②	
		Silver	5V DC ±5%	SPDT	HA4L-M1C51②	—		
				DPDT	HA4L-M1C61②			
			12V AC/DC ±10%	SPDT	HA4L-M1C53②			
				DPDT	HA4L-M1C63②			
			24V AC/DC ±10%	SPDT	HA4L-M1C54②			
				DPDT	HA4L-M1C64②			
ø30 Mushroom HA1L-□3  Marking plate size: ø14.8mm Engraving area: ø12.8mm (Depth: 0.5mm max.) 	Momentary	Gold	5V DC ±5%	SPDT	HA1L-M3C11②		HA1L-M3C11V②	
				DPDT	HA1L-M3C21②		HA1L-M3C21V②	
			12V AC/DC ±10%	SPDT	HA1L-M3C13②		HA1L-M3C13V②	
				DPDT	HA1L-M3C23②		HA1L-M3C23V②	
			24V AC/DC ±10%	SPDT	HA1L-M3C14②		HA1L-M3C14V②	
				DPDT	HA1L-M3C24②		HA1L-M3C24V②	
		Silver	5V DC ±5%	SPDT	HA1L-M3C51②	—		
				DPDT	HA1L-M3C61②			
			12V AC/DC ±10%	SPDT	HA1L-M3C53②			
				DPDT	HA1L-M3C63②			
			24V AC/DC ±10%	SPDT	HA1L-M3C54②			
				DPDT	HA1L-M3C64②			
	Maintained	Gold	5V DC ±5%	SPDT	HA1L-A3C11②		HA1L-A3C11V②	
				DPDT	HA1L-A3C21②		HA1L-A3C21V②	
			12V AC/DC ±10%	SPDT	HA1L-A3C13②		HA1L-A3C13V②	
				DPDT	HA1L-A3C23②		HA1L-A3C23V②	
			24V AC/DC ±10%	SPDT	HA1L-A3C14②		HA1L-A3C14V②	
				DPDT	HA1L-A3C24②		HA1L-A3C24V②	
		Silver	5V DC ±5%	SPDT	HA1L-A3C51②	—		
				DPDT	HA1L-A3C61②			
			12V AC/DC ±10%	SPDT	HA1L-A3C53②			
				DPDT	HA1L-A3C63②			
			24V AC/DC ±10%	SPDT	HA1L-A3C54②			
				DPDT	HA1L-A3C64②			

Specify a color code in place of ② in the Part No.
 A: amber
 G: green
 PW: pure white
 R: red
 S: blue
 W: white
 Y: yellow

• See page 25 for marking plate size and engraving area. • One LED lamp is installed in an illuminated pushbutton.
 • White lens type (when light off) is available (except HA1L-□3). Clear lens is used instead of colored lens for amber, green, red, and blue illuminated pushbuttons. Amber, green, red, or blue LED units are used. To specify, insert W before ② in the part number.
 Example: HA4L-M1C24W②.

Dimensions

Round
Square
Round w/Square
Bezel

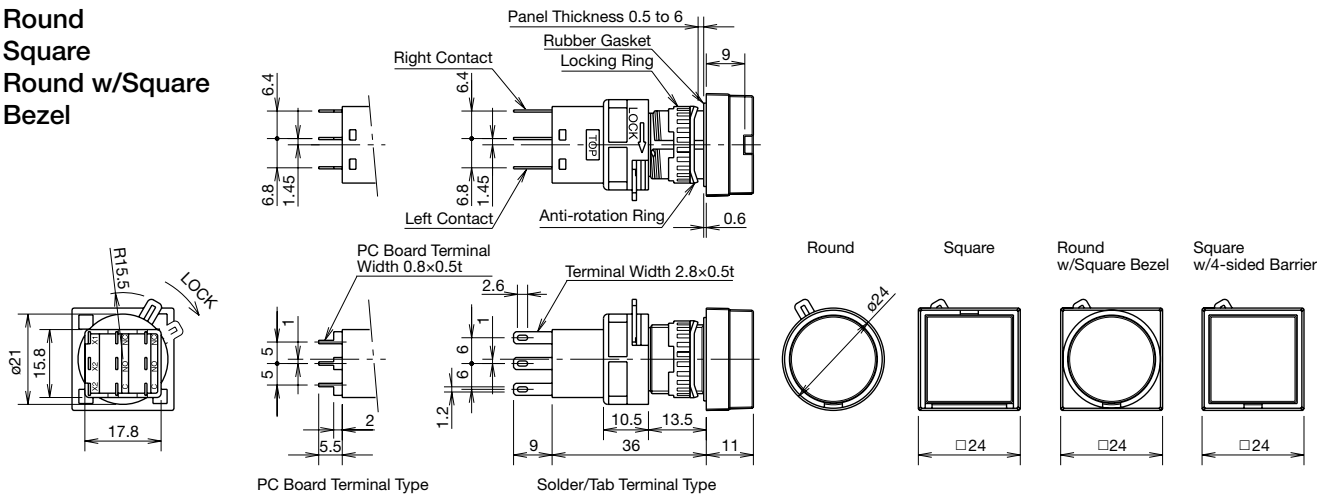

Mushroom

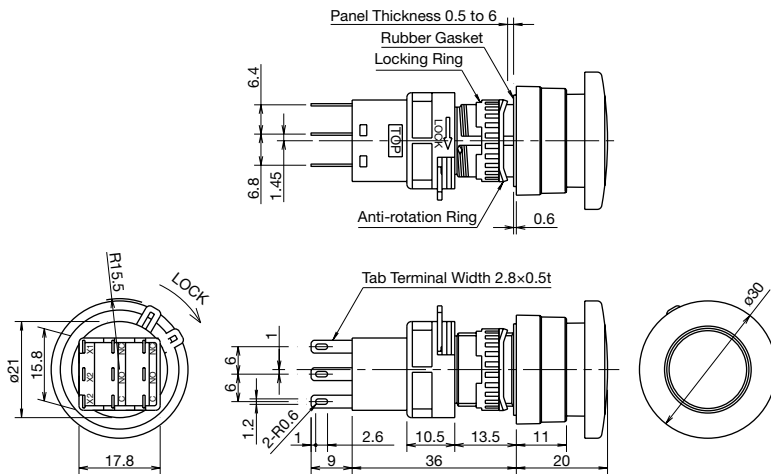

Mounting Hole Layout Mounting Centers

Round
Square
Round w/Square Bezel

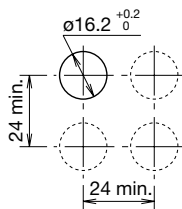

PC Board Drilling Layout (Bottom View)

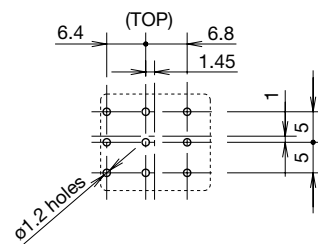

• See Single Board Mounting on page 25 for details about PC boards.

Terminal Arrangement (Bottom View)

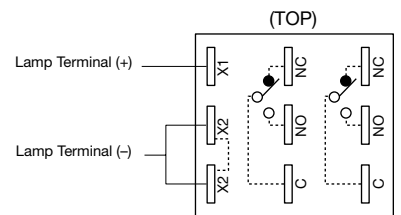

- SPDT has C, NO, and NC on the right only.
- X2 and X2 are wired internally.

Mushroom

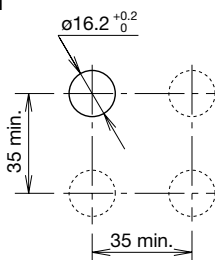









Note: Determine mounting centers to ensure easy operation.

All dimensions in mm.

ø16 H6 Series Miniature Switches & Pilot Lights









HA1P/HA2P/HA3P/HA4P Pilot Lights

W/Removable Contact Block

Shape	Operating Voltage	Part No.		② Illumination Color Code
		Solder/Tab Terminal	PC Board Terminal	
Round HA1P  Marking plate size: ø18.4mm Engraving area: ø16.8mm (Depth: 0.5mm max.) 	5V DC ±5%	HA1P-1C01②	HA1P-1C01V②	Specify a color code in place of ② in the Part No. A: amber G: green PW: pure white R: red S: blue W: white Y: yellow
	12V AC/DC ±10%	HA1P-1C03②	HA1P-1C03V②	
	24V AC/DC ±10%	HA1P-1C04②	HA1P-1C04V②	
Square HA2P  Marking plate size: □18.4mm Engraving area: □16.4mm (Depth: 0.5mm max.) 	5V DC ±5%	HA2P-1C01②	HA2P-1C01V②	
	12V AC/DC ±10%	HA2P-1C03②	HA2P-1C03V②	
	24V AC/DC ±10%	HA2P-1C04②	HA2P-1C04V②	
Round w/Square Bezel HA3P  Marking plate size: ø18.4mm Engraving area: ø16.8mm (Depth: 0.5mm max.) 	5V DC ±5%	HA3P-1C01②	HA3P-1C01V②	
	12V AC/DC ±10%	HA3P-1C03②	HA3P-1C03V②	
	24V AC/DC ±10%	HA3P-1C04②	HA3P-1C04V②	
Square w/Four-sided Barrier HA4P  Marking plate size: □18.4mm Engraving area: □16.4mm (Depth: 0.5mm max.) 	5V DC ±5%	HA4P-1C01②	HA4P-1C01V②	
	12V AC/DC ±10%	HA4P-1C03②	HA4P-1C03V②	
	24V AC/DC ±10%	HA4P-1C04②	HA4P-1C04V②	

- See page 7 for dimensions. • See page 25 for marking plate size and engraving area.
- One LED lamp is installed in an illuminated pilot light. • White lens type (when light off) is available. Clear lens is used instead of colored lens for amber, green, red, and blue pilot lights. Amber, green, red, or blue LED units are used. To specify, insert **W** before ② in the part number. Example: HA1P-1C04**W**②.

Unibody

Shape	Operating Voltage	Part No.		② Illumination Color Code
		Solder/Tab Terminal	PC Board Terminal	
Round HA1P  Marking plate size: ø18.4mm Engraving area: ø16.8mm (Depth: 0.5mm max.) 	5V DC ±5%	HA1P-11②	—	Specify a color code in place of ② in the Part No. A: amber G: green PW: pure white R: red S: blue W: white Y: yellow
	12V AC/DC ±10%	HA1P-13②	—	
	24V AC/DC ±10%	HA1P-14②	—	
Square HA2P  Marking plate size: □18.4mm Engraving area: □16.4mm (Depth: 0.5mm max.) 	5V DC ±5%	HA2P-11②	—	
	12V AC/DC ±10%	HA2P-13②	—	
	24V AC/DC ±10%	HA2P-14②	—	
Round w/Square Bezel HA3P  Marking plate size: ø18.4mm Engraving area: ø16.8mm (Depth: 0.5mm max.) 	5V DC ±5%	HA3P-11②	—	
	12V AC/DC ±10%	HA3P-13②	—	
	24V AC/DC ±10%	HA3P-14②	—	
Square w/Four-sided Barrier HA4P  Marking plate size: □18.4mm Engraving area: □16.4mm (Depth: 0.5mm max.) 	5V DC ±5%	HA4P-11②	—	
	12V AC/DC ±10%	HA4P-13②	—	
	24V AC/DC ±10%	HA4P-14②	—	

- See page 7 for dimensions. • See page 25 for marking plate size and engraving area.
- One LED lamp is installed in an illuminated pilot light. • White lens type (when light off) is available. Clear lens is used instead of colored lens for amber, green, red, and blue pilot lights. Amber, green, red, or blue LED units are used. To specify, insert **W** before ② in the part number. Example: HA1P-14**W**②.

Dimensions

W/Removable Contact Block

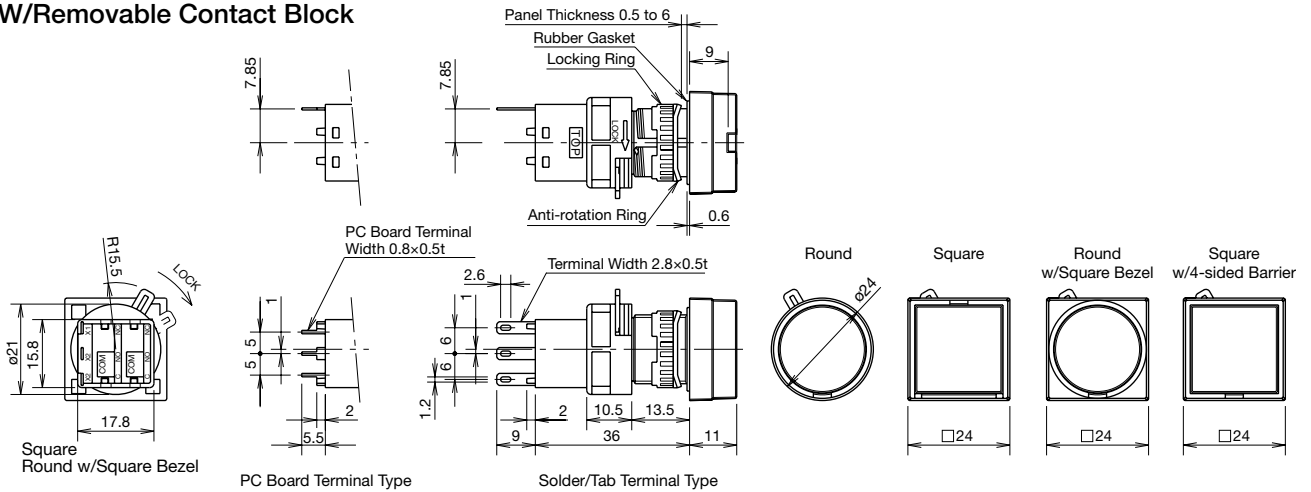

Unibody

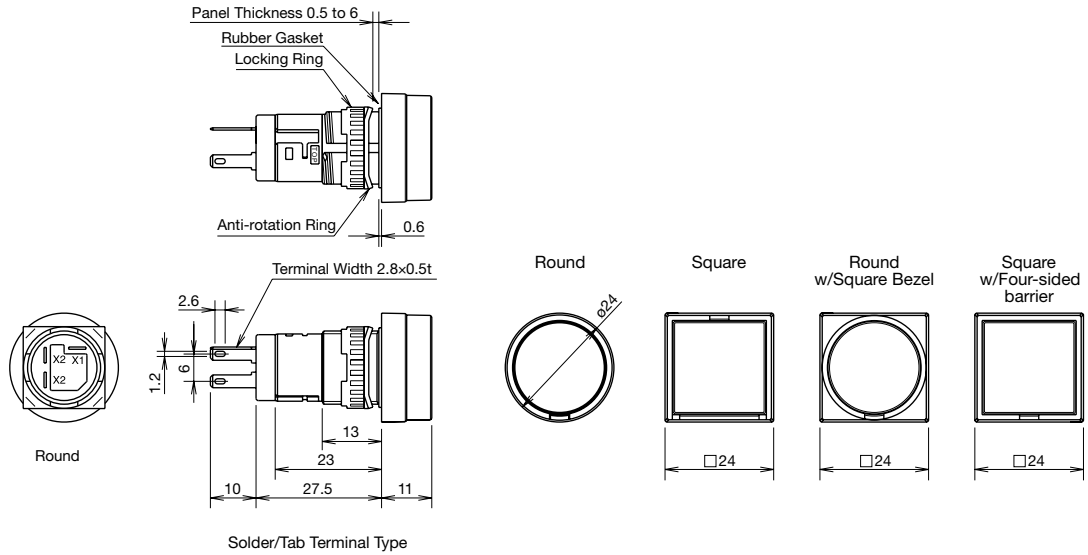

Mounting Hole Layout Mounting Centers

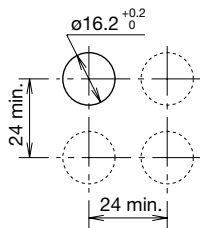

PC Board Drilling Layout (Bottom View)

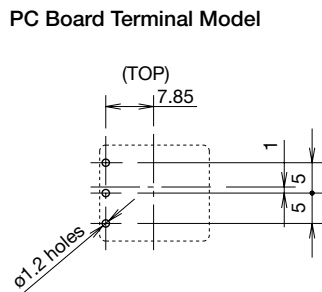

- See Single Board Mounting on page 25 for details about PC boards.



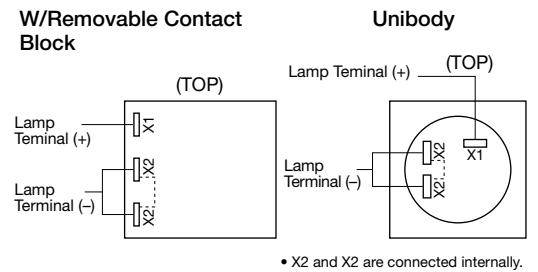





Terminal Arrangement (Bottom View)



All dimensions in mm.











ø16 H6 Series Miniature Switches & Pilot Lights

HA1B/HA2B/HA3B/HA4B Pushbuttons

Shape	Button Style	Operation	Contact	Part No.		Color Code ①②	
				Solder/Tab Terminal	PC Board Terminal		
Round HA1B-□1  	Button	Momentary	Gold	SPDT	HA1B-M1C1①	HA1B-M1C1V①	B: black G: green R: red S: blue W: white Y: yellow
				DPDT	HA1B-M1C2①	HA1B-M1C2V①	
			Silver	SPDT	HA1B-M1C5①	—	
		DPDT		HA1B-M1C6①	—		
		Maintained	Gold	SPDT	HA1B-A1C1①	HA1B-A1C1V①	
				DPDT	HA1B-A1C2①	HA1B-A1C2V①	
	Silver		SPDT	HA1B-A1C5①	—		
		DPDT	HA1B-A1C6①	—			
	Illumination Lens	Momentary	Gold	SPDT	HA1B-M1C1L②	HA1B-M1C1VL②	A: amber G: green R: red S: blue W: white Y: yellow
				DPDT	HA1B-M1C2L②	HA1B-M1C2VL②	
			Silver	SPDT	HA1B-M1C5L②	—	
		DPDT		HA1B-M1C6L②	—		
Maintained		Gold	SPDT	HA1B-A1C1L②	HA1B-A1C1VL②		
			DPDT	HA1B-A1C2L②	HA1B-A1C2VL②		
	Silver	SPDT	HA1B-A1C5L②	—			
DPDT		HA1B-A1C6L②	—				
Square HA2B-□1  	Button	Momentary	Gold	SPDT	HA2B-M1C1①	HA2B-M1C1V①	B: black G: green R: red S: blue W: white Y: yellow
				DPDT	HA2B-M1C2①	HA2B-M1C2V①	
			Silver	SPDT	HA2B-M1C5①	—	
		DPDT		HA2B-M1C6①	—		
		Maintained	Gold	SPDT	HA2B-A1C1①	HA2B-A1C1V①	
				DPDT	HA2B-A1C2①	HA2B-A1C2V①	
	Silver		SPDT	HA2B-A1C5①	—		
		DPDT	HA2B-A1C6①	—			
	Illumination Lens	Momentary	Gold	SPDT	HA2B-M1C1L②	HA2B-M1C1VL②	A: amber G: green R: red S: blue W: white Y: yellow
				DPDT	HA2B-M1C2L②	HA2B-M1C2VL②	
			Silver	SPDT	HA2B-M1C5L②	—	
		DPDT		HA2B-M1C6L②	—		
Maintained		Gold	SPDT	HA2B-A1C1L②	HA2B-A1C1VL②		
			DPDT	HA2B-A1C2L②	HA2B-A1C2VL②		
	Silver	SPDT	HA2B-A1C5L②	—			
DPDT		HA2B-A1C6L②	—				
Round w/Square Bezel HA3B-□1  	Button	Momentary	Gold	SPDT	HA3B-M1C1①	HA3B-M1C1V①	B: black G: green R: red S: blue W: white Y: yellow
				DPDT	HA3B-M1C2①	HA3B-M1C2V①	
			Silver	SPDT	HA3B-M1C5①	—	
		DPDT		HA3B-M1C6①	—		
		Maintained	Gold	SPDT	HA3B-A1C1①	HA3B-A1C1V①	
				DPDT	HA3B-A1C2①	HA3B-A1C2V①	
	Silver		SPDT	HA3B-A1C5①	—		
		DPDT	HA3B-A1C6①	—			
	Illumination Lens	Momentary	Gold	SPDT	HA3B-M1C1L②	HA3B-M1C1VL②	A: amber G: green R: red S: blue W: white Y: yellow
				DPDT	HA3B-M1C2L②	HA3B-M1C2VL②	
			Silver	SPDT	HA3B-M1C5L②	—	
		DPDT		HA3B-M1C6L②	—		
Maintained		Gold	SPDT	HA3B-A1C1L②	HA3B-A1C1VL②		
			DPDT	HA3B-A1C2L②	HA3B-A1C2VL②		
	Silver	SPDT	HA3B-A1C5L②	—			
DPDT		HA3B-A1C6L②	—				
Square w/Four-sided Barrier HA4B-M1  	Button	Momentary	Gold	SPDT	HA4B-M1C1①	HA4B-M1C1V①	B: black G: green R: red S: blue W: white Y: yellow
				DPDT	HA4B-M1C2①	HA4B-M1C2V①	
			Silver	SPDT	HA4B-M1C5①	—	
	DPDT	HA4B-M1C6①		—			
	Illumination Lens	Maintained	Gold	SPDT	HA4B-M1C1L②	HA4B-M1C1VL②	A: amber G: green R: red S: blue W: white Y: yellow
				DPDT	HA4B-M1C2L②	HA4B-M1C2VL②	
Silver			SPDT	HA4B-M1C5L②	—		
	DPDT	HA4B-M1C6L②	—				

- Specify a color code in place of ① or ② in the Part No. • For dimensions, see page 10.
- Illuminated lenses cannot be installed on button type pushbuttons.
- Black lens type is available for illumination lens type (not CCC approved). Clear lens and black marking plate are used. To specify, insert B in place of ② in the part number. Example: HA1B-M1C2LB.

HA1B/HA2B/HA3B/HA4B Pushbuttons

Shape	Button Style	Operation	Contact	Part No.		Color Code ①			
				Solder/Tab Terminal	PC Board Terminal				
Extended Round HA1B-□2  	Button	Momentary	Gold	SPDT	HA1B-M2C1①	HA1B-M2C1V①	B: black G: green R: red S: blue W: white Y: yellow		
				DPDT	HA1B-M2C2①	HA1B-M2C2V①			
			Silver	SPDT	HA1B-M2C5①	—			
				DPDT	HA1B-M2C6①	—			
		Maintained	Gold	SPDT	HA1B-A2C1①	HA1B-A2C1V①			
				DPDT	HA1B-A2C2①	HA1B-A2C2V①			
			Silver	SPDT	HA1B-A2C5①	—			
				DPDT	HA1B-A2C6①	—			
		Square HA2B-□2  	Button	Momentary	Gold	SPDT		HA2B-M2C1①	HA2B-M2C1V①
						DPDT		HA2B-M2C2①	HA2B-M2C2V①
					Silver	SPDT		HA2B-M2C5①	—
						DPDT		HA2B-M2C6①	—
Maintained	Gold			SPDT	HA2B-A2C1①	HA2B-A2C1V①			
				DPDT	HA2B-A2C2①	HA2B-A2C2V①			
	Silver			SPDT	HA2B-A2C5①	—			
				DPDT	HA2B-A2C6①	—			
Round w/Square Bezel HA3B-□2  	Button			Momentary	Gold	SPDT	HA3B-M2C1①	HA3B-M2C1V①	
						DPDT	HA3B-M2C2①	HA3B-M2C2V①	
					Silver	SPDT	HA3B-M2C5①	—	
						DPDT	HA3B-M2C6①	—	
		Maintained	Gold	SPDT	HA3B-A2C1①	HA3B-A2C1V①			
				DPDT	HA3B-A2C2①	HA3B-A2C2V①			
			Silver	SPDT	HA3B-A2C5①	—			
				DPDT	HA3B-A2C6①	—			
		Square w/Four-sided Barrier HA4B-M2  	Button	Momentary	Gold	SPDT	HA4B-M2C1①	HA4B-M2C1V①	
						DPDT	HA4B-M2C2①	HA4B-M2C2V①	
					Silver	SPDT	HA4B-M2C5①	—	
						DPDT	HA4B-M2C6①	—	
Round HA1B-□3 ø30mm Mushroom  	Button			Momentary	Gold	SPDT	HA1B-M3C1①	HA1B-M3C1V①	
						DPDT	HA1B-M3C2①	HA1B-M3C2V①	
					Silver	SPDT	HA1B-M3C5①	—	
						DPDT	HA1B-M3C6①	—	
				Maintained	Gold	SPDT	HA1B-A3C1①	HA1B-A3C1V①	
						DPDT	HA1B-A3C2①	HA1B-A3C2V①	
					Silver	SPDT	HA1B-A3C5①	—	
						DPDT	HA1B-A3C6①	—	

- Specify a color code in place of ① in the Part No.
- For dimensions, see page 10.

ø16 H6 Series Miniature Switches & Pilot Lights

Dimensions

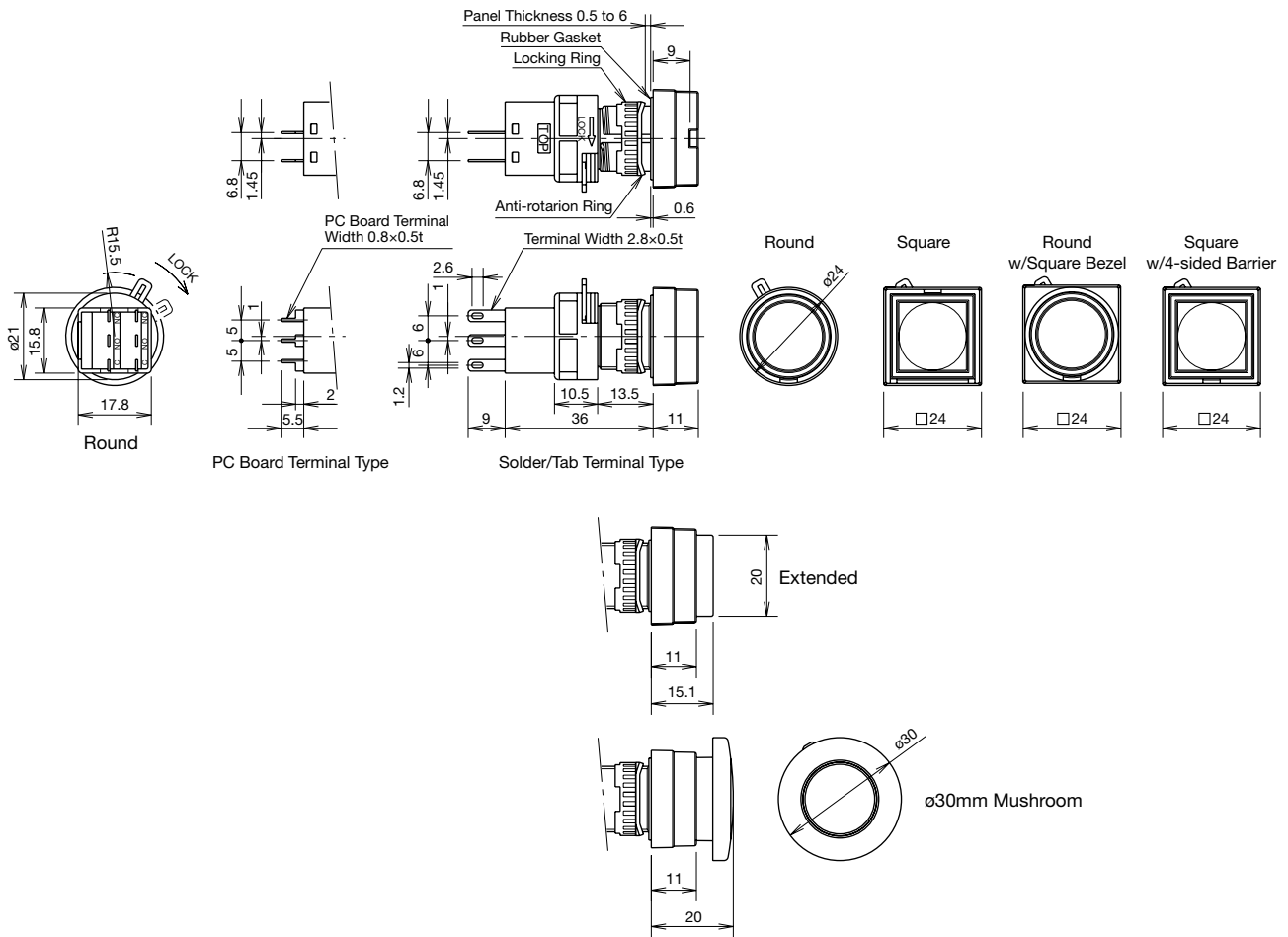

Mounting Hole Layout Mounting Centers

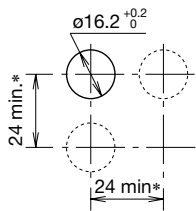

* 35 min. for mushroom type

Note: Determine mounting centers to ensure easy operation.

PC Board Drilling Layout (Bottom View)

PC Board Terminal Model

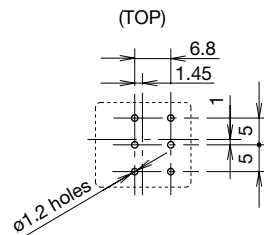

• See Single Board Mounting on page 25 for details about PC boards.



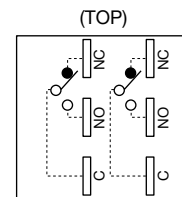





Terminal Arrangement (Bottom View)



• SPDT has C, NO, and NC on the right only.















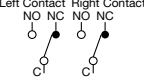

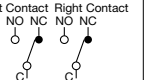
All dimensions in mm.

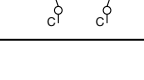
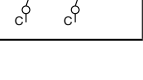
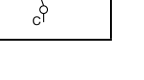
HA1S/HA3S Selector Switches

Shape	Operator Position		Operation	Contact		Part No.		
						Solder/Tab Terminal	PC Board Terminal	
 	90° 2-position	Maintained		Gold	SPDT	HA1S-2C1	HA1S-2C1V	
					DPDT	HA1S-2C2	HA1S-2C2V	
				Silver	SPDT	HA1S-2C5	—	
					DPDT	HA1S-2C6	—	
		Spring return from right	Gold	SPDT	HA1S-21C1	HA1S-21C1V		
				DPDT	HA1S-21C2	HA1S-21C2V		
			Silver	SPDT	HA1S-21C5	—		
				DPDT	HA1S-21C6	—		
	45° 3-position	Maintained		Gold	DPDT	HA1S-3C2	HA1S-3C2V	
					Silver	DPDT	HA1S-3C6	—
				Spring return from right	Gold	DPDT	HA1S-31C2	HA1S-31C2V
						Silver	DPDT	HA1S-31C6
		Spring return from left	Gold	DPDT	HA1S-32C2	HA1S-32C2V		
				Silver	DPDT	HA1S-32C6	—	
		Spring return two-way	Gold	DPDT	HA1S-33C2	HA1S-33C2V		
				Silver	DPDT	HA1S-33C6	—	
 	90° 2-position	Maintained		Gold	SPDT	HA3S-2C1	HA3S-2C1V	
					DPDT	HA3S-2C2	HA3S-2C2V	
				Silver	SPDT	HA3S-2C5	—	
					DPDT	HA3S-2C6	—	
		Spring return from right	Gold	SPDT	HA3S-21C1	HA3S-21C1V		
				DPDT	HA3S-21C2	HA3S-21C2V		
			Silver	SPDT	HA3S-21C5	—		
				DPDT	HA3S-21C6	—		
	45° 3-position	Maintained		Gold	DPDT	HA3S-3C2	HA3S-3C2V	
					Silver	DPDT	HA3S-3C6	—
				Spring return from right	Gold	DPDT	HA3S-31C2	HA3S-31C2V
						Silver	DPDT	HA3S-31C6
		Spring return from left	Gold	DPDT	HA3S-32C2	HA3S-32C2V		
				Silver	DPDT	HA3S-32C6	—	
		Spring return two-way	Gold	DPDT	HA3S-33C2	HA3S-33C2V		
				Silver	DPDT	HA3S-33C6	—	

- Bezel: black
- Knob: black with white indicator
- See page 12 for dimensions.

Contact Operation

Operator Position & Contact Operation (Top View)					
Positions		Contact	↖ Left	↑ Center	↗ Right
90° 2-position	 Maintained	SPDT		—	
			 Spring return from right	DPDT	Left Contact Right Contact 
45° 3-position	 Maintained	DPDT	Left Contact Right Contact 		Left Contact Right Contact 
	 Spring return from right		Left Contact Right Contact 	Left Contact Right Contact 	Left Contact Right Contact 
	 Spring return from left		Left Contact Right Contact 	Left Contact Right Contact 	Left Contact Right Contact 
	 Spring return two-way		Left Contact Right Contact 	Left Contact Right Contact 	Left Contact Right Contact 

ø16 H6 Series Miniature Switches & Pilot Lights

Dimensions

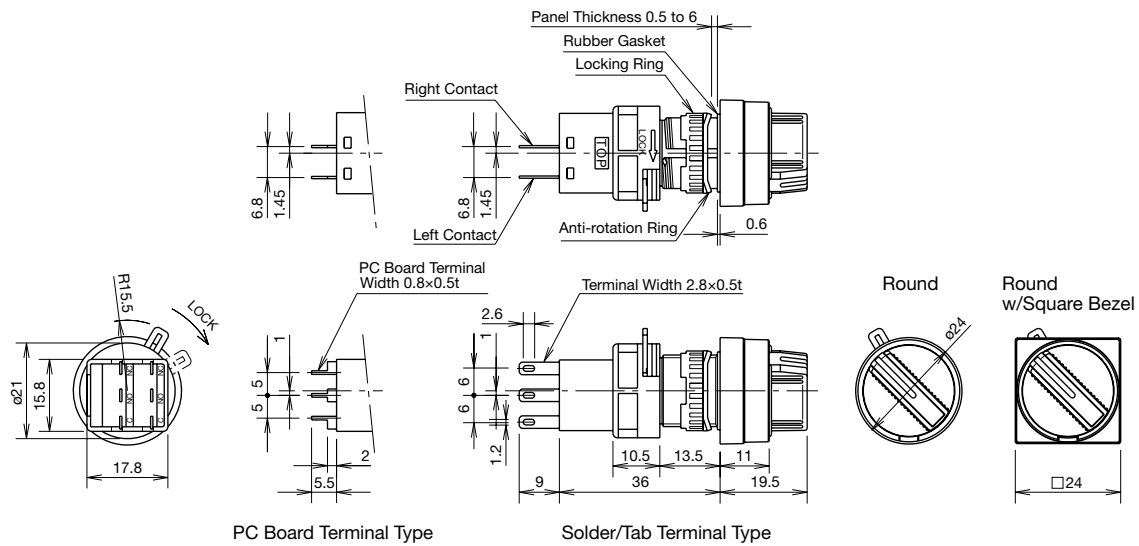

Mounting Hole Layout Mounting Centers

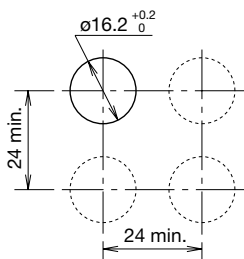

Note: Determine mounting centers to ensure easy operation.

PC Board Drilling Layout (Bottom View)

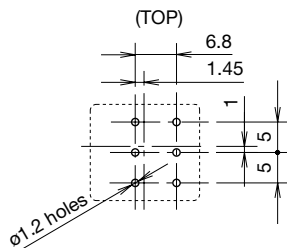

• See Single Board Mounting on page 25 for details about PC boards.



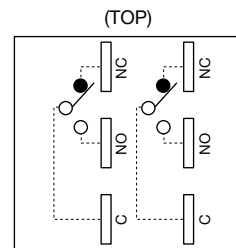















Terminal Arrangement (Bottom View)



• SPDT has C, NO, and NC on the right only.













All dimensions in mm.

HA1K Key Selector Switches



Shape	Operator Position		Keys Retained at ●	Contact		Part No.			
						Solder/Tab Terminal	PC Board Terminal		
 	90° 2-position	Maintained	A		Gold	SPDT	HA1K-2C1A	HA1K-2C1VA	
				Silver	DPDT	HA1K-2C2A	HA1K-2C2VA		
			B		Gold	SPDT	HA1K-2C1B	HA1K-2C1VB	
				Silver	DPDT	HA1K-2C2B	HA1K-2C2VB		
			C		Gold	SPDT	HA1K-2C1C	HA1K-2C1VC	
				Silver	DPDT	HA1K-2C2C	HA1K-2C2VC		
		Spring return from right	B		Gold	SPDT	HA1K-21C1B	HA1K-21C1VB	
				Silver	DPDT	HA1K-21C2B	HA1K-21C2VB		
				Gold	SPDT	HA1K-21C5B	—		
				Silver	DPDT	HA1K-21C6B	—		
		45° 3-position	Maintained	A		Gold	DPDT	HA1K-3C2A	HA1K-3C2VA
					Silver	DPDT	HA1K-3C6A	—	
				B		Gold	DPDT	HA1K-3C2B	HA1K-3C2VB
					Silver	DPDT	HA1K-3C6B	—	
				C		Gold	DPDT	HA1K-3C2C	HA1K-3C2VC
					Silver	DPDT	HA1K-3C6C	—	
	D				Gold	DPDT	HA1K-3C2D	HA1K-3C2VD	
				Silver	DPDT	HA1K-3C6D	—		
	E				Gold	DPDT	HA1K-3C2E	HA1K-3C2VE	
				Silver	DPDT	HA1K-3C6E	—		
	G				Gold	DPDT	HA1K-3C2G	HA1K-3C2VG	
				Silver	DPDT	HA1K-3C6G	—		
	H			Gold	DPDT	HA1K-3C2H	HA1K-3C2VH		
			Silver	DPDT	HA1K-3C6H	—			
	Spring return from right		B		Gold	DPDT	HA1K-31C2B	HA1K-31C2VB	
				Silver	DPDT	HA1K-31C6B	—		
			D		Gold	DPDT	HA1K-31C2D	HA1K-31C2VD	
				Silver	DPDT	HA1K-31C6D	—		
	Spring return from left		C		Gold	DPDT	HA1K-32C2C	HA1K-32C2VC	
				Silver	DPDT	HA1K-32C6C	—		
			D		Gold	DPDT	HA1K-32C2D	HA1K-32C2VD	
				Silver	DPDT	HA1K-32C6D	—		
	H			Gold	DPDT	HA1K-32C2H	HA1K-32C2VH		
			Silver	DPDT	HA1K-32C6H	—			
	Spring return two-way	D		Gold	DPDT	HA1K-33C2D	HA1K-33C2VD		
			Silver	DPDT	HA1K-33C6D	—			

- Two keys are supplied. • The front of key cylinder is made of black plastic. • See page 15 for dimensions.
- Besides the standard key (key number 231), three other key numbers are available (2/3/5). To specify, add the key number in the part number as: HA1K-3C2A-2

Contact Operation

Operator Position & Contact Operation (Top View)					
Positions		Contact	↙ Left	↑ Center	↗ Right
90° 2-position	 Maintained	SPDT		—	
	 Spring return from right	DPDT		—	
45° 3-position	 Maintained	DPDT			
	 Spring return from right				
	 Spring return from left				
	 Spring return two-way				

HA3K Key Selector Switches

Shape	Operator Position	Keys Retained at ●	Contact	Part No.				
				Solder/Tab Terminal	PC Board Terminal			
Round w/Square Bezel HA3K  	90° 2-position	Maintained	A	●	Gold	SPDT	HA3K-2C1A	HA3K-2C1VA
				●	Silver	DPDT	HA3K-2C2A	HA3K-2C2VA
			B	●	Gold	SPDT	HA3K-2C1B	HA3K-2C1VB
				●	Silver	DPDT	HA3K-2C2B	HA3K-2C2VB
			C	●	Gold	SPDT	HA3K-2C5A	—
				●	Silver	DPDT	HA3K-2C6A	—
		Spring return from right	B	●	Gold	SPDT	HA3K-2C5B	—
				●	Silver	DPDT	HA3K-2C6B	—
			C	●	Gold	SPDT	HA3K-2C1C	HA3K-2C1VC
				●	Silver	DPDT	HA3K-2C2C	HA3K-2C2VC
			B	●	Gold	SPDT	HA3K-21C1B	HA3K-21C1VB
				●	Silver	DPDT	HA3K-21C2B	HA3K-21C2VB
	45° 3-position	Maintained	A	●	Gold	DPDT	HA3K-3C2A	HA3K-3C2VA
				●	Silver	DPDT	HA3K-3C6A	—
			B	●	Gold	DPDT	HA3K-3C2B	HA3K-3C2VB
				●	Silver	DPDT	HA3K-3C6B	—
			C	●	Gold	DPDT	HA3K-3C2C	HA3K-3C2VC
				●	Silver	DPDT	HA3K-3C6C	—
			D	●	Gold	DPDT	HA3K-3C2D	HA3K-3C2VD
				●	Silver	DPDT	HA3K-3C6D	—
			E	●	Gold	DPDT	HA3K-3C2E	HA3K-3C2VE
				●	Silver	DPDT	HA3K-3C6E	—
			G	●	Gold	DPDT	HA3K-3C2G	HA3K-3C2VG
				●	Silver	DPDT	HA3K-3C6G	—
		H	●	Gold	DPDT	HA3K-3C2H	HA3K-3C2VH	
			●	Silver	DPDT	HA3K-3C6H	—	
		Spring return from right	B	●	Gold	DPDT	HA3K-31C2B	HA3K-31C2VB
				●	Silver	DPDT	HA3K-31C6B	—
			D	●	Gold	DPDT	HA3K-31C2D	HA3K-31C2VD
				●	Silver	DPDT	HA3K-31C6D	—
			G	●	Gold	DPDT	HA3K-31C2G	HA3K-31C2VG
				●	Silver	DPDT	HA3K-31C6G	—
		Spring return from left	C	●	Gold	DPDT	HA3K-32C2C	HA3K-32C2VC
				●	Silver	DPDT	HA3K-32C6C	—
			D	●	Gold	DPDT	HA3K-32C2D	HA3K-32C2VD
				●	Silver	DPDT	HA3K-32C6D	—
H	●		Gold	DPDT	HA3K-32C2H	HA3K-32C2VH		
	●		Silver	DPDT	HA3K-32C6H	—		
Spring return two-way	D	●	Gold	DPDT	HA3K-33C2D	HA3K-33C2VD		
		●	Silver	DPDT	HA3K-33C6D	—		

- Two keys are supplied.
- The front of key cylinder is made with black plastic.
- See page 15 for dimensions.
- Besides the standard key (key number 231), three other key numbers are available (2/3/5). To specify, add the key number in the part number as: HA3K-3C2A-2

Contact Operation

Operator Position & Contact Operation (Top View)					
Positions		Contact	↙ Left	↑ Center	↗ Right
90° 2-position	Maintained	SPDT	NO NC C1	—	NO NC C1
	Spring return from right	DPDT	Left Contact Right Contact NO NC NO NC C1 C1	—	Left Contact Right Contact NO NC NO NC C1 C1
45° 3-position	Maintained	DPDT	Left Contact Right Contact NO NC NO NC C1 C1	Left Contact Right Contact NO NC NO NC C1 C1	Left Contact Right Contact NO NC NO NC C1 C1
	Spring return from right				
	Spring return from left				
	Spring return two-way				

Dimensions

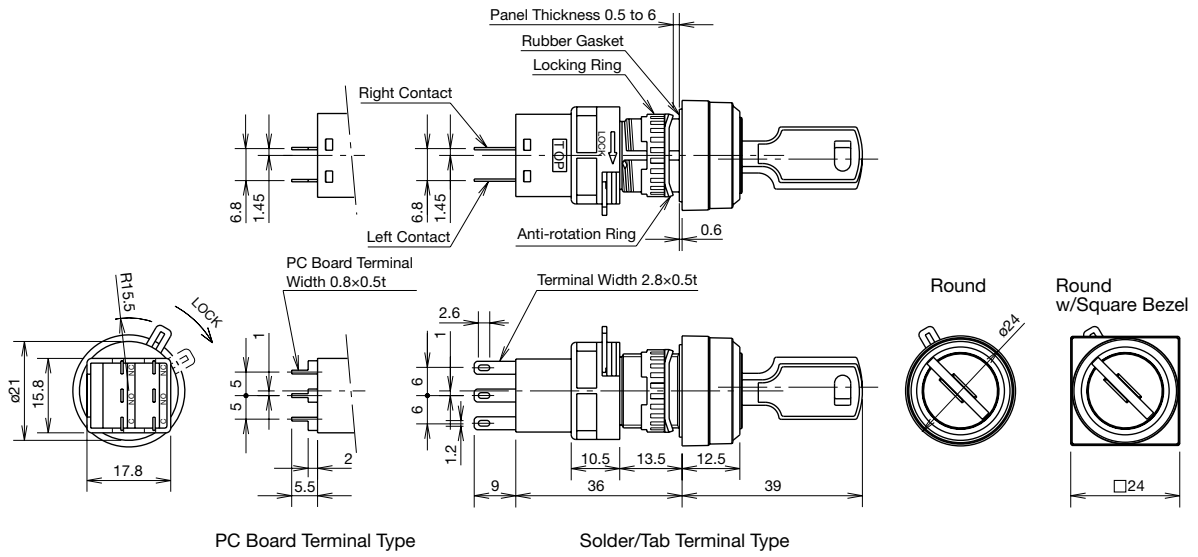

Mounting Hole Layout Mounting Centers

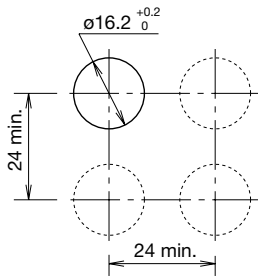

Note: Determine mounting centers to ensure easy operation.

PC Board Drilling Layout (Bottom View)

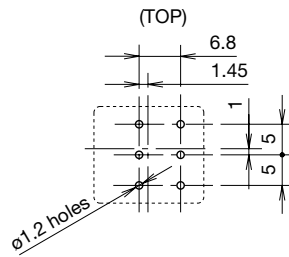

• See Single Board Mounting on page 25 for details about PC boards.



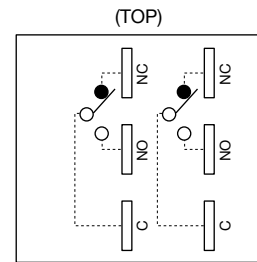





Terminal Arrangement (Bottom View)



• SPDT has C, NO, and NC on the right only.

All dimensions in mm.











HA1F Illuminated Selector Switches

Shape	Operator Position	Contact Material	Operating Voltage	Contact	Part No.		Color Code ②	
					Solder/Tab Terminal	PC Board Terminal		
Round HA1F  	90° 2-position	Maintained 	5V DC ±5%	SPDT	HA1F-2C11②	HA1F-2C11V②	Specify a lens color code in place of ② in the Part No. A: amber G: green PW: pure white R: red S: blue W: white Y: yellow	
				DPDT	HA1F-2C21②	HA1F-2C21V②		
			12V AC/DC ±10%	SPDT	HA1F-2C13②	HA1F-2C13V②		
				DPDT	HA1F-2C23②	HA1F-2C23V②		
			24V AC/DC ±10%	SPDT	HA1F-2C14②	HA1F-2C14V②		
				DPDT	HA1F-2C24②	HA1F-2C24V②		
		Silver	5V DC ±5%	SPDT	HA1F-2C51②	-		
				DPDT	HA1F-2C61②			
			12V AC/DC ±10%	SPDT	HA1F-2C53②			
				DPDT	HA1F-2C63②			
			24V AC/DC ±10%	SPDT	HA1F-2C54②			
				DPDT	HA1F-2C64②			
	Spring return from right 	Gold	5V DC ±5%	SPDT	HA1F-21C11②			HA1F-21C11V②
				DPDT	HA1F-21C21②			HA1F-21C21V②
			12V AC/DC ±10%	SPDT	HA1F-21C13②			HA1F-21C13V②
				DPDT	HA1F-21C23②			HA1F-21C23V②
			24V AC/DC ±10%	SPDT	HA1F-21C14②			HA1F-21C14V②
				DPDT	HA1F-21C24②			HA1F-21C24V②
		Silver	5V DC ±5%	SPDT	HA1F-21C51②	-		
				DPDT	HA1F-21C61②			
			12V AC/DC ±10%	SPDT	HA1F-21C53②			
				DPDT	HA1F-21C63②			
			24V AC/DC ±10%	SPDT	HA1F-21C54②			
				DPDT	HA1F-21C64②			
45° 3-position	Maintained 	5V DC ±5%	DPDT	HA1F-3C21②	HA1F-3C21V②			
			DPDT	HA1F-3C23②	HA1F-3C23V②			
		12V AC/DC ±10%	DPDT	HA1F-3C24②	HA1F-3C24V②			
			DPDT	HA1F-3C61②	-			
		24V AC/DC ±10%	DPDT	HA1F-3C63②				
			DPDT	HA1F-3C64②				
	Spring return from right 	Gold	5V DC ±5%	DPDT		HA1F-31C21②	HA1F-31C21V②	
				DPDT		HA1F-31C23②	HA1F-31C23V②	
		12V AC/DC ±10%	DPDT	HA1F-31C24②		HA1F-31C24V②		
			DPDT	HA1F-31C61②		-		
		24V AC/DC ±10%	DPDT	HA1F-31C63②				
			DPDT	HA1F-31C64②				
Spring return from left 	Gold	5V DC ±5%	DPDT	HA1F-32C21②			HA1F-32C21V②	
			DPDT	HA1F-32C23②			HA1F-32C23V②	
	12V AC/DC ±10%	DPDT	HA1F-32C24②	HA1F-32C24V②				
		DPDT	HA1F-32C61②	-				
	24V AC/DC ±10%	DPDT	HA1F-32C63②					
		DPDT	HA1F-32C64②					
Spring return two-way 	Gold	5V DC ±5%	DPDT		HA1F-33C21②	HA1F-33C21V②		
			DPDT		HA1F-33C23②	HA1F-33C23V②		
	12V AC/DC ±10%	DPDT	HA1F-33C24②		HA1F-33C24V②			
		DPDT	HA1F-33C61②	-				
	24V AC/DC ±10%	DPDT	HA1F-33C63②					
		DPDT	HA1F-33C64②					

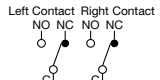

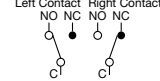
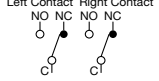
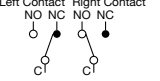
• See page 18 for dimensions.

• One LED lamp is installed in illuminated selector switch.

Contact Operation

Operator Position & Contact Operation (Top View)					
Positions		Contact	Left	Center	Right
90° 2-position	Maintained 	SPDT		—	
	Spring return from right 	DPDT		—	
45° 3-position	Maintained 	DPDT			
	Spring return from right 				
	Spring return from left 				
	Spring return two-way 				

HA3F Illuminated Selector Switches

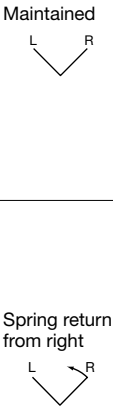
Shape	Operator Position	Contact Material	Operating Voltage	Contact	Part No.		Color Code ②		
					Solder/Tab Terminal	PC Board Terminal			
 	90° 2-position 	Gold	5V DC ±5%	SPDT	HA3F-2C11②	HA3F-2C11V②	Specify a lens color code in place of ② in the Part No. A: amber G: green PW: pure white R: red S: blue W: white Y: yellow		
				DPDT	HA3F-2C21②	HA3F-2C21V②			
			12V AC/DC ±10%	SPDT	HA3F-2C13②	HA3F-2C13V②			
				DPDT	HA3F-2C23②	HA3F-2C23V②			
			24V AC/DC ±10%	SPDT	HA3F-2C14②	HA3F-2C14V②			
				DPDT	HA3F-2C24②	HA3F-2C24V②			
		Silver	5V DC ±5%	SPDT	HA3F-2C51②	-			
				DPDT	HA3F-2C61②				
			12V AC/DC ±10%	SPDT	HA3F-2C53②				
				DPDT	HA3F-2C63②				
			24V AC/DC ±10%	SPDT	HA3F-2C54②				
				DPDT	HA3F-2C64②				
		Spring return from right	Gold	5V DC ±5%	SPDT			HA3F-21C11②	HA3F-21C11V②
					DPDT			HA3F-21C21②	HA3F-21C21V②
				12V AC/DC ±10%	SPDT			HA3F-21C13②	HA3F-21C13V②
					DPDT			HA3F-21C23②	HA3F-21C23V②
				24V AC/DC ±10%	SPDT			HA3F-21C14②	HA3F-21C14V②
					DPDT			HA3F-21C24②	HA3F-21C24V②
	Silver		5V DC ±5%	SPDT	HA3F-21C51②			-	
				DPDT	HA3F-21C61②				
			12V AC/DC ±10%	SPDT	HA3F-21C53②				
				DPDT	HA3F-21C63②				
			24V AC/DC ±10%	SPDT	HA3F-21C54②				
				DPDT	HA3F-21C64②				
	45° 3-position	Maintained	Gold	5V DC ±5%	DPDT	HA3F-3C21②			HA3F-3C21V②
					DPDT	HA3F-3C23②			HA3F-3C23V②
					DPDT	HA3F-3C24②			HA3F-3C24V②
			Silver	5V DC ±5%	DPDT	HA3F-3C61②			-
					DPDT	HA3F-3C63②			
					DPDT	HA3F-3C64②			
		Spring return from right	Gold	5V DC ±5%	DPDT	HA3F-31C21②		HA3F-31C21V②	
					DPDT	HA3F-31C23②		HA3F-31C23V②	
					DPDT	HA3F-31C24②		HA3F-31C24V②	
			Silver	5V DC ±5%	DPDT	HA3F-31C61②		-	
					DPDT	HA3F-31C63②			
					DPDT	HA3F-31C64②			
Spring return from left		Gold	5V DC ±5%	DPDT	HA3F-32C21②	HA3F-32C21V②			
				DPDT	HA3F-32C23②	HA3F-32C23V②			
				DPDT	HA3F-32C24②	HA3F-32C24V②			
		Silver	5V DC ±5%	DPDT	HA3F-32C61②	-			
				DPDT	HA3F-32C63②				
				DPDT	HA3F-32C64②				
Spring return two-way	Gold	5V DC ±5%	DPDT	HA3F-33C21②	HA3F-33C21V②				
			DPDT	HA3F-33C23②	HA3F-33C23V②				
			DPDT	HA3F-33C24②	HA3F-33C24V②				
	Silver	5V DC ±5%	DPDT	HA3F-33C61②	-				
			DPDT	HA3F-33C63②					
			DPDT	HA3F-33C64②					

• See page 18 for dimensions.

• One LED lamp is installed in illuminated selector switch.

Contact Operation

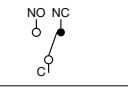
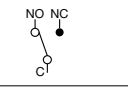
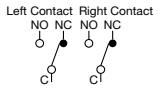
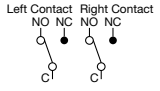
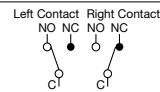
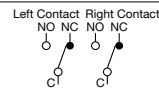
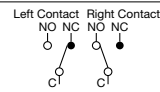
Operator Position & Contact Operation (Top View)					
Positions		Contact	Left	Center	Right
90° 2-position	Maintained	SPDT		—	
	Spring return from right	DPDT		—	
45° 3-position	Maintained	DPDT			
	Spring return from right				
	Spring return from left				
	Spring return two-way				

ø16 H6 Series Miniature Switches & Pilot Lights

Dimensions

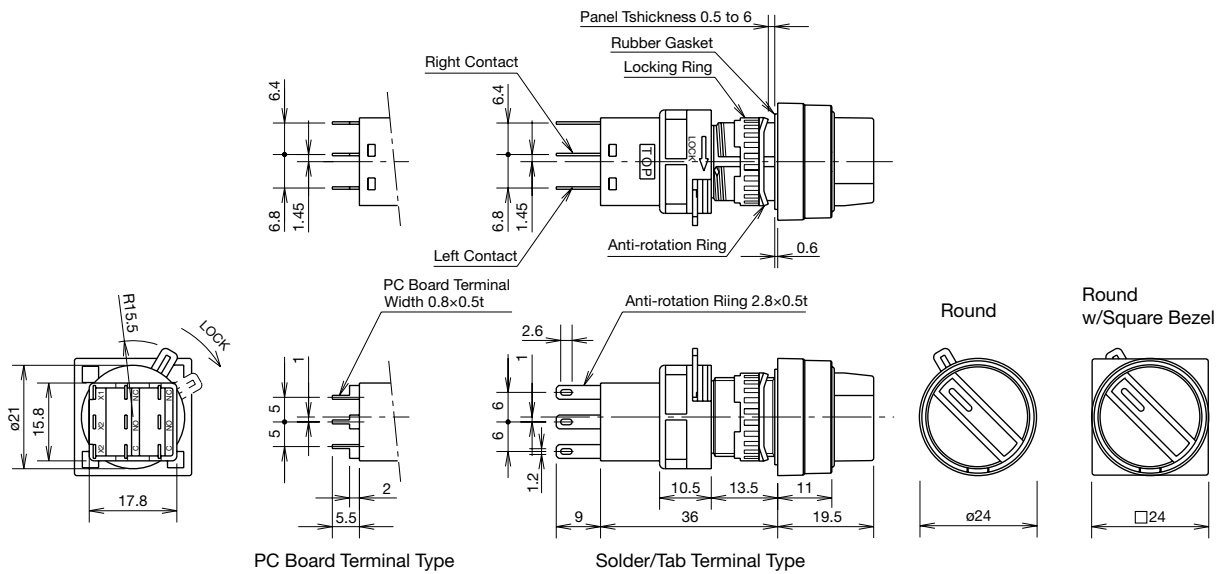

Mounting Hole Layout Mounting Centers

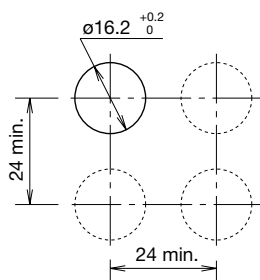

Note: Determine mounting centers to ensure easy operation.

PC Board Drilling Layout (Bottom View)

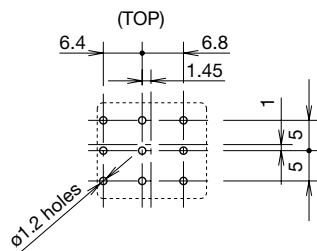

• See Single Board Mounting on page 25 for details about PC boards.



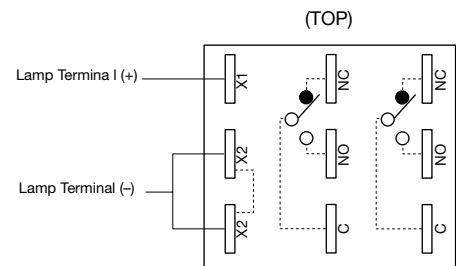











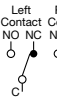

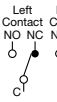
Terminal Arrangement (Bottom View)

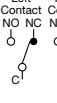

• SPDT has C, NO, and NC on the right only.
• X2 and X2 are wired internally.

All dimensions in mm.

HA1R Selector Pushbuttons

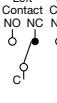
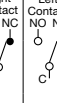
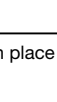
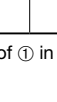
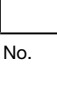
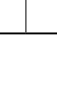
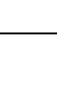
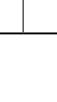
Shape	Operator Position	Contact Operation						Contact Material	Contact	Part No. Terminal Style	Color Code ^①		
		L 		C 		R 							
		Normal	Push	Normal	Push	Normal	Push						
Round HA1R  	90° 2-position	Maintained			—	—			Gold	DPDT	Solder Tab Terminal HA1R-2C2 ^①	B: black G: green R: red S: blue Y: yellow	
					—	—			Silver	DPDT	PC Board Terminal HA1R-2C2V ^①		
	45° 3-position						Blocked			Gold	DPDT		Solder Tab Terminal HA1R-3C2 ^①
							Blocked			Silver	DPDT		PC Board Terminal HA1R-3C2V ^①

• Specify a button color code in place of ① in the Part No.

Dimensions

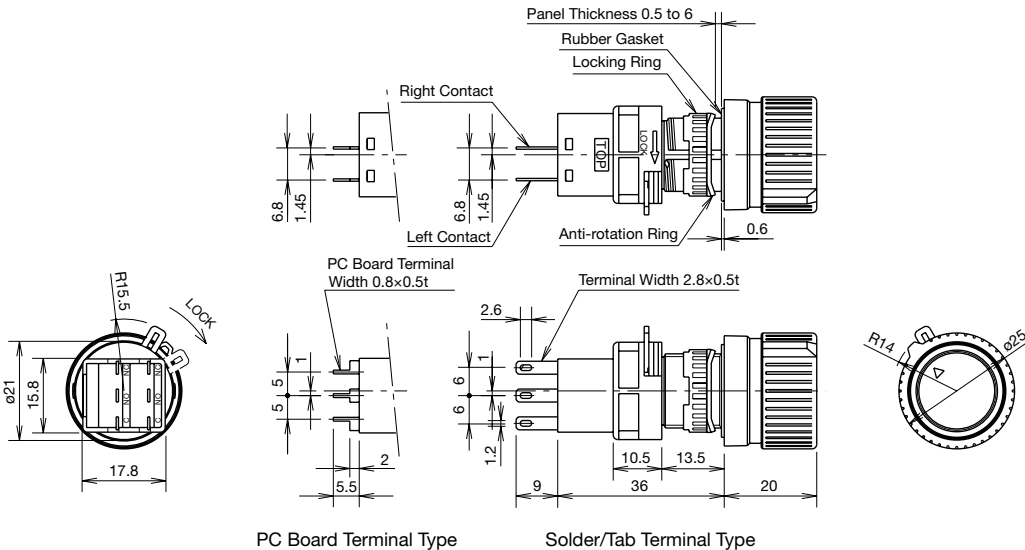

PC Board Terminal Type

Solder/Tab Terminal Type

Mounting Hole Layout Mounting Centers

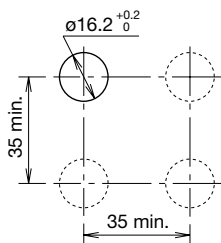

Note: Determine mounting centers to ensure easy operation.

PC Board Panel Cut-out (Bottom View)

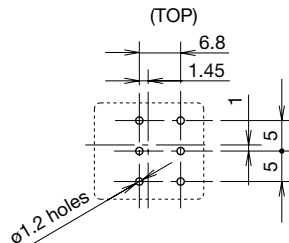

• See Single Board Mounting on page 25 for details about PC boards.



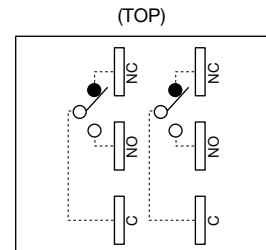





Terminal Arrangement (Bottom View)

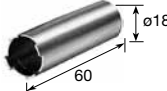

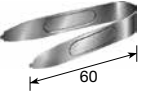

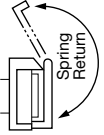

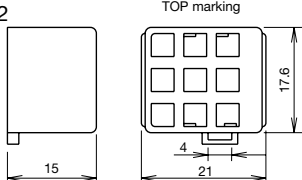

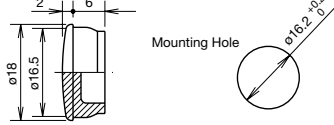
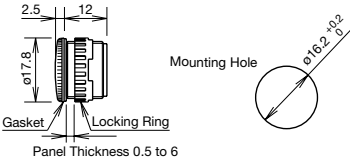









All dimensions in mm.

ø16 H6 Series Miniature Switches & Pilot Lights

Accessories

Shape	Material	Part No.	Ordering Part No.	Package Quantity	Remarks	
	Metal (nickel-plated brass)	MT-001	MT-001	1	<ul style="list-style-type: none"> Used to tighten the locking ring when installing H6 into a panel. Tighten the locking ring to a torque of 0.88 N·m. 	
	Rubber (nitril)	OR-44	OR-44	1	<ul style="list-style-type: none"> Used to install and remove LED lamps. 	
	Stainless Steel	MT-101	MT-101	1	<ul style="list-style-type: none"> Used to remove the lens or buttons. 	
Switch Guard (180° spring return) 	Standard	Guard (Polyarylate) Base (polyacetal)	HA9Z-K1	HA9Z-K1	1	<ul style="list-style-type: none"> Degree of protection: IP65 Used to protect flush pushbuttons from inadvertent operation. 
	For single board (see page 25)		HA9Z-KW1	HA9Z-KW1	1	
Terminal Cover 	Standard	Nylon (white)	H6-VL2	H6-VL2PN10	10	<ul style="list-style-type: none"> Terminal cover is not attached and must be ordered separately. When wiring the terminals, insert the lead wires into the terminal cover holes before soldering. 
	Exclusive for Unibody Pilot Light		H6-PVL	H6-PVLPN10	10	
Mounting Hole Plug 	Rubber	Nitril Rubber (black)	AL-B6	AL-B6PN05	5	<ul style="list-style-type: none"> Degree of protection: IP65 
	Metal	Plug: Metal (diecast) Locking ring: plastic Gasket: nitril	AL-BM6	AL-BM6	1	<ul style="list-style-type: none"> Degree of protection: IP65 Tightening torque: 0.1 to 0.29 N·m 

Maintenance Parts

Shape		Specification	Part No.	Ordering Part No.	Package Quantity	Remarks	
Lens  ①  ②  ③	Round, Round w/Square Bezel	Polyarylate	HA9Z-L11②	HA9Z-L11②PN05	5	Specify a color code in place of ② in the Part No. A (amber), C (clear), G (green), R (red), S (blue), Y (yellow) Note: Use C (clear) lens for PW (pure white) or W (white) illumination.	
	Square		HA9Z-L21②	HA9Z-L21②PN05			
	ø30mm Lens		HA9Z-L13②	HA9Z-L13②PN05			
Button  ①  ②  ③  ④  ⑤  ⑥  ⑦	Round Flush, Round w/Square Bezel	Polyacetal	HA9Z-B11①	HA9Z-B11①PN05	2	Specify a color code in place of ① in the Part No. B (black), G (green), R (red), S (blue), W (white), Y (yellow)	
	Square Flush		HA9Z-B21①	HA9Z-B21①PN05			
	Round Extended, Round Extended w/Square Bezel		HA9Z-B12①	HA9Z-B12①PN05			
	Square Extended		HA9Z-B22①	HA9Z-B22①PN05			
	ø30mm Button		HA9Z-B13①	HA9Z-B13①PN05			
	Selector Pushbutton		HA1A-R1①	HA1A-R1①PN02			
Marking Plate 	Round, Round w/Square Bezel	Acrylic	White	HA9Z-P1W	5	<ul style="list-style-type: none"> • HA9Z-P1W (engraving area: ø16.4 mm, engraving depth: 0.5 mm max.) • HA9Z-P2W (engraving area: □16.4 mm, engraving depth: 0.5 mm max.) 	
	Square		Black	HA9Z-P1B			HA9Z-P1BPN05
			White	HA9Z-P2W			HA9Z-P2WPN05
			Black	HA9Z-P2B			HA9Z-P2BPN05
Locking Ring 	For all types	Polyacetal	HA9Z-LN	HA9Z-LNPN10	10		
Anti-rotation Ring 	For all types except for HA1E	Stainless Steel	HA9Z-LP	HA9Z-LPPN10			
Lever Lock 	For all types except for collective mounting and HA1E	Polyacetal	HA9Z-LS	HA9Z-LSPN10	5	<ul style="list-style-type: none"> • Lever lock is not attached and must be ordered separately. • Yellow 	
Selector Color Insert 	For selector switch	Polyacetal	HA9Z-HC1①	HA9Z-HC1①PN05		Specify a color code in place of ① in the Part No. G (green), R (red), S (blue), W (white), Y (yellow)	
Spare Key 	For key selector switches	Nickel-plated Brass	KG9Z-SK-231	KG9Z-SK-231PN02	2	<ul style="list-style-type: none"> • Thickness: 2.0mm • Besides the standard key number (231), three other numbers (2, 3, 5) are available. Ordering part number: KG9Z-SK-2PN02 KG9Z-SK-3PN02 KG9Z-SK-5PN02	
Illuminated Selector Knob 	For illuminated selector switch	Polyarylate (w/water-proof gasket)	HA1A-F②	HA1A-F②	1	Specify a color code in place of ② in the Part No. A (amber), G (green), R (red), S (blue), W (white), Y (yellow) Note: Use W (white) knob for PW (pure white) illumination.	

ø16 H6 Series Miniature Switches & Pilot Lights

LED Lamps

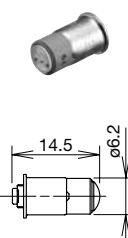
Dimension	Rated Voltage	Current Draw		Part No.	Ordering Part No.	② Illumination Color Code	Package Quantity	Base
		DC	AC					
	5V DC	8 mA	—	LFTD-5②	LFTD-5②	Specify a color code in place of ② in the Ordering Part No.	1	SX6S/8x5.4
					LFTD-5②PN10		10	
	6V AC/DC	7 mA	9 mA (A, R, W) 10 mA (G, PW, S)	LFTD-6②	LFTD-6②	A: amber G: green PW: pure white R: red S: blue W: white	1	
					LFTD-6②PN10		10	
	12V AC/DC	8 mA	9 mA	LFTD-1②	LFTD-1②	Use a PW (pure white) LED lamp for yellow illumination.	1	
					LFTD-1②PN10		10	
	24V AC/DC	8 mA	9 mA	LFTD-2②	LFTD-2②		1	
					LFTD-2②PN10		10	

Transformer

Transformer	Rated Voltage	Operating Voltage Range	Part No.	Applicable LED Lamp
For 24V  CE	100/110V AC	100/110V AC ±10%	TWR512	LFTD-2②
	200/220V AC	200/220V AC ±10%	TWR522	
	400/440V AC	400/440V AC ±10%	TWR542	

- Terminal covers are supplied with separate mounting type transformers.
- Connect only one LFTD LED to separate mounting type transformers.

Specifications

Rated Voltage	100/110V AC, 200/220V AC, 400/440V AC (50/60 Hz)	
Power Consumption	2.4VA	
Rated Insulation Voltage	600V	
Insulation Resistance	100 MΩ minimum (500V DC megger)	
Dielectric Strength	2500V AC, 1 minute	
Standard Operating Condition	Operating Temperature	-30 to +60°C (no freezing)
	Relative Humidity	35 to 85% (no condensation)
Vibration Resistance	Operating Extremes	5 to 55 Hz, amplitude 0.5 mm
	Damage Limits	1,000 m/s ² (100G)
Shock Resistance		
Terminal Screw	M3.5	
Applicable Wire	2 mm ² maximum, 2 wires maximum	

Dimensions

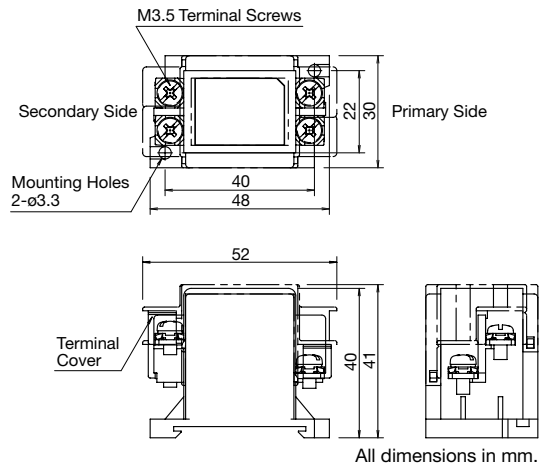

Accessories

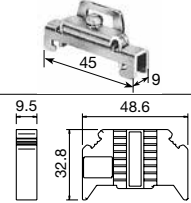
Description	Appearance	Description	Part No.	Ordering Part No.	Package Quantity
DIN Rail		Aluminum Weight: Approx. 200g	BAA1000	BAA1000PN10	
		Steel Weight: Approx. 320g	BAP1000	BAP1000PN10	
End Clip		Steel Weight: Approx. 15g	BNL6	BNL6PN10	10
		Plastic Weight: Approx. 15g	BC9Z-E/NS35N	BC9Z-E/NS35NPN10	

Dimensions

Terminal Cover

For W/removable Contact Block (H6-VL2)

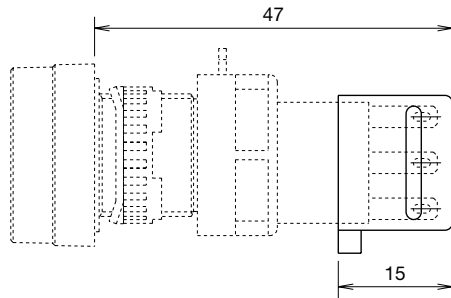

For Unibody (H6-PVL)

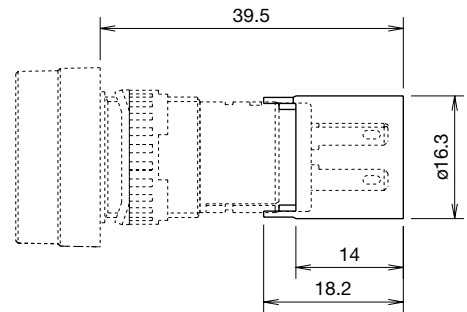

Switch Guard

For Flush Pushbuttons and Illuminated Pushbuttons

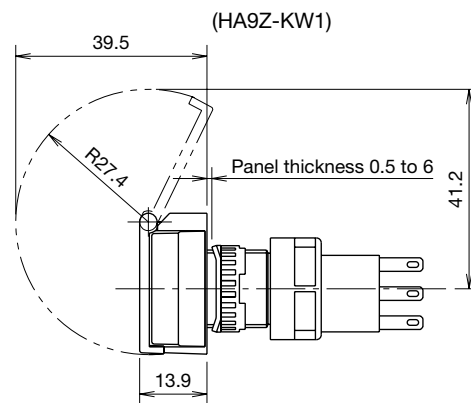
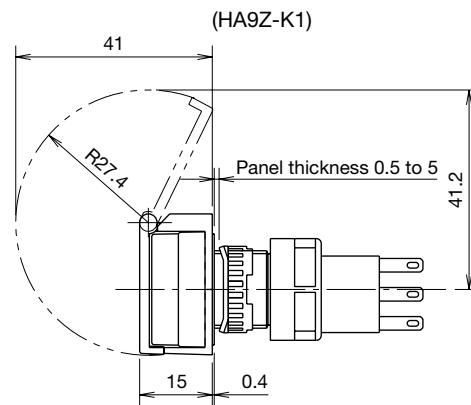
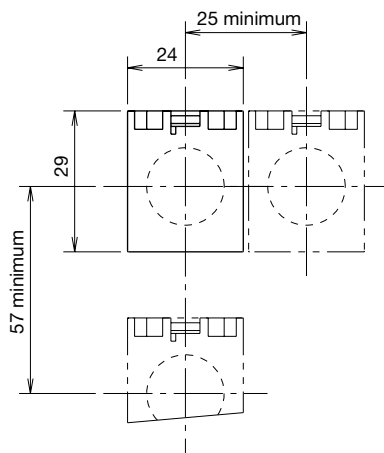

All dimensions in mm.

Safety Precautions

- Turn off the power to H6 series before installation, removal, wiring, maintenance, and inspection of the units. Failure to turn power off may cause electrical shocks or fire hazard.
- To avoid burning your hand, use the lamp holder tool when replacing lamps.
- For wiring, use wires of a proper gauge to meet voltage and

current requirements. Improper soldering may cause overheating and create a fire hazard.

Instructions

Replacement of Lens and Marking Plate

Removing the Lens Assembly

Remove the lens assembly (color lens, marking plate, and lens holder) by inserting a screwdriver into the recess of the lens through the bezel.

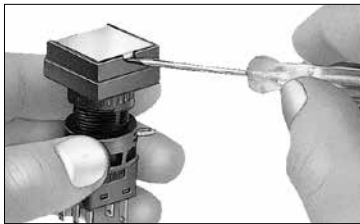

Removing the Marking Plate

Remove the marking plate by pushing the lens from the rear to disengage the latches between the lens and the lens holder, using the screwdriver as shown below.

Note: The translucent filter in the lens holder cannot be removed because this filter is sealed to make the unit waterproof.

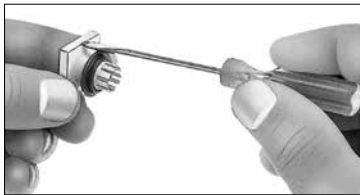

Installing

For round lens types, place the marking plate on the lens holder with the projection engaged and press the lens onto the lens holder to engage the latches. For square lens types, insert the marking plate into the lens, and press the lens onto the holder to engage the latches.

Note: Make sure of correct orientation of the marking plate.

[Round Lens Type]

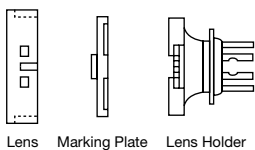

[Square Lens Type]

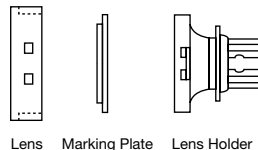

Replacement of Lamps

Lamps can be replaced using the lamp holder tool (OR-44) from the front of the panel, or by removing the contact block from the operator.

Removing the Lamp

1. Slip the lamp holder tool onto the lamp head. Then push slightly, and turn the lamp holder tool counterclockwise.



2. Push the bulb, and remove from the rear of the lamp holder.

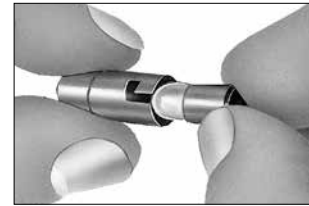

Installing the Lamp

1. Insert the lamp into the lamp holder from the rear, and push in completely using the smaller end of the lamp holder tool.

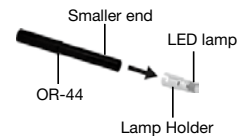

2. Hold the bulb with the lamp holder tool as shown below.

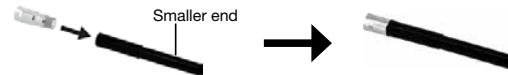

3. Place the insertion guide of the lamp holder and the TOP marking side or the groove in the operator unit in the same direction. Insert the lamp holder into the housing with the lamp holder tool. Then push the lamp lightly and turn it clockwise to install.

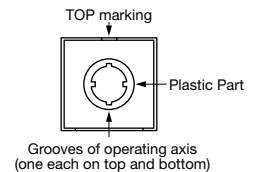

Panel Mounting

Remove the contact block from the operator. Insert the operator into the panel cut-out from the front, then install the contact block to the operator.

Removing the Contact Block

Turn the locking lever on the contact block in the direction opposite to the arrow on the housing. Then the contact block can be removed.



Installing the Contact Block

Insert the contact block with the TOP markings on the contact block and the operator placed in the same direction. Then lock the units, turning the locking lever in the direction of the arrow.

Notes for Mounting

Use the optional Ring Wrench (MT-001) to mount the operator onto a panel. Tightening torque should not exceed 0.88 N·m. Do not use pliers. Do not tighten with excessive force, otherwise the locking ring will be damaged.

Collective Mounting

As the locking lever can be turned easily from the rear of the units using a screwdriver, the contact blocks can be removed even when mounted collectively.

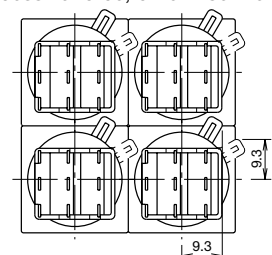

Instructions

Marking Plates and Films

For H6 series illuminated pushbuttons and pilot lights, legends and symbols can be engraved on marking plates, or printed mylar film can be inserted under the lens for labelling purposes.

Marking Plate and Marking Film Size

Lens	Round Lens (round, round w/square bezel)	Square Lens
Built-in Marking Plate	<p>• Engraving must be made on the engraving area within 0.5mm deep. • The marking plate is made of white acrylic resin.</p>	
Applicable Marking Film	<p>• Two 0.1mm-thick films or one 0.2mm-thick film can be installed in the lens. • Marking film is not included. • Recommended marking film: Polyester film</p>	

Insertion Order of Marking Plate and Film

[Round Lens Type]

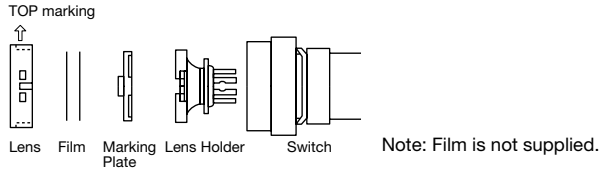

[Square Lens Type]

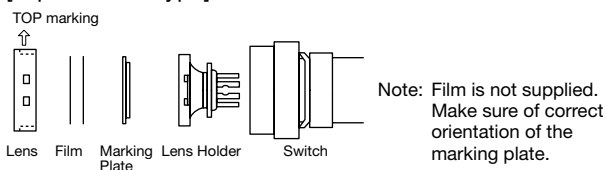

Wiring

- Solder the terminals at 350°C within 3 seconds using a 60W soldering iron. Sn-Ag-Cu type is recommended when using lead-free solder. When soldering, do not touch the H6 with the soldering iron. Also ensure that no tensile force is applied to the terminal. Do not bend the terminal or apply excessive force to the terminal.
- Use non-corrosive liquid flux.

Notes on Terminal Cover

Insert the terminal cover into the contact block with the TOP markings on the contact block and the terminal cover in the same direction.

Note: When wiring, insert the lead wires into the terminal cover holes before soldering.

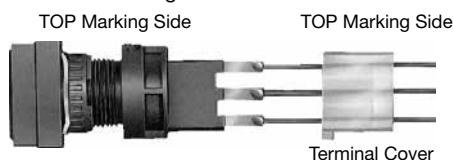

Connection

Positive-lock connector and easy-lock connector are applicable to tab terminals.

Recommended Connectors

Item	Positive-lock Connector (Tyco Electronics)		Easy-lock Connector (Nichifu Co., Ltd.)	
	Terminal	0.2 to 0.5 mm ²	175412-1	0.2 to 0.3 mm ²
	0.2 to 1.25 mm ²	174778-1	0.5 to 1.25 mm ²	OSS-62815F3
Housing	174779-1		NET1-28-1P	

Note: Positive-lock is a registered trademark of Tyco Electronics.

Single Board Mounting

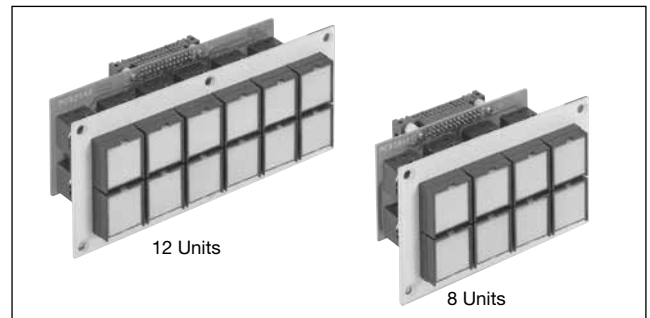

Mounting the PC board terminal type units on a PC board offers the following features.

Features

- Reduced installation labor, easy wiring, space saving, and standardization.
- Since the contact blocks on the PC board can be removed easily using a locking lever, the H6 series is easy to maintain.
- Because the H6 series requires no studs for fastening the unit to a PC board, special preparation of the control panel is not needed.
- Switch guard for single board mounting is also available (page 20).

Notes for Designing PC board and Circuit

- Use 1.6-mm-thick glass epoxy PC board with drilled holes.
- Design a circuit so that the H6 series can operate within the rated voltage and current range. Make sure that inrush current and voltage do not exceed the rating.
- Minimum applicable load is 5V AC/DC, 1 mA on gold contacts. Applicable range is subject to the operating condition and load.
- Since the 2.8-mm-wide terminal touches the PC board as shown on the right, short circuit may occur with pattern lines. Design a circuit carefully to prevent short circuit.

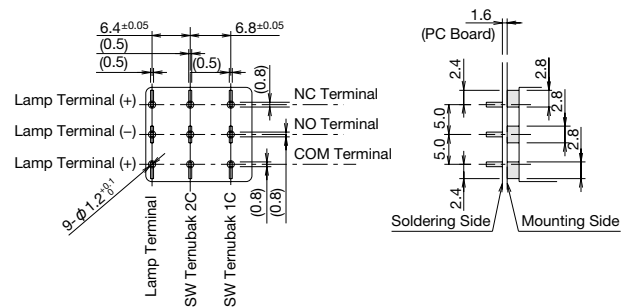

ø16 H6 Series Miniature Switches & Pilot Lights

PC Board Drilling Layout

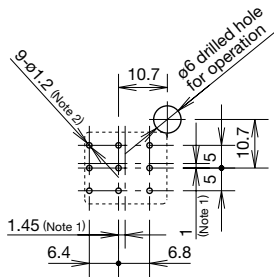

Note 1: When designing, note the alignment of centerlines of the contact blocks and centerlines of the operators.

Note 2: The diameter of the terminal hole is 1.2 mm.

Switchguard for Single Board Mounting



Part No. HA9Z-KW1

See page 23 for dimensions.

Note: H6 series with or without switchguard can be used on a single board, as the depth behind the panel to the PC board is the same.

Installation and Removal of Contact Blocks

Turn the locking lever to install and remove the contact block on the PC board by using a screwdriver from a hole (ø6 mm) of the PC board.

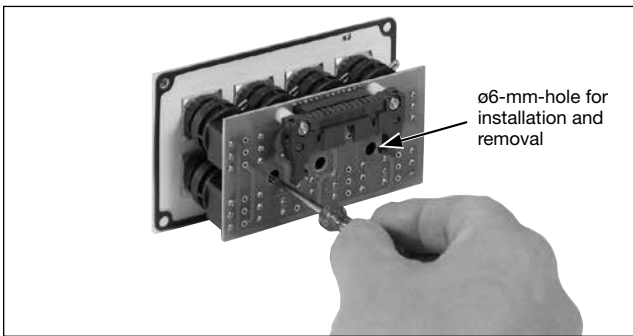

Hole diameter may vary to meet installation requirements. When the locking lever can be turned by using a screwdriver from the upper or right space, the holes are not necessary.

<Example>

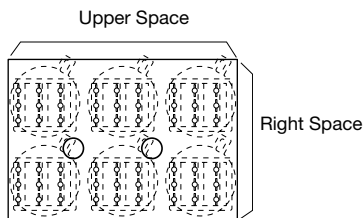

Mounting Holes and Assembly Procedure

• Drill mounting holes in the panel as shown below. When the units are mounted collectively, provide adequate clearance.

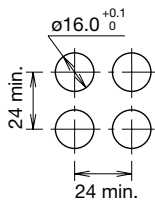

(ø30 mushroom: 35mm minimum)

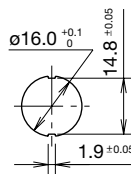

(panel cut-out for positioning)

• Assembly Procedure

1. Install the operator to the operation panel.
2. Insert the contact block to the operator from the rear.
3. Turn the lock lever to lock the contact block.
4. Insert the PC board to terminals and solder.

Note 1: Make sure that each terminal is inserted into the PC board correctly.

Note 2: Do not apply tensile force to the connector cable for extended period of time.

Note 3: Do not expose the contact block to water.

Note 4: Ensure to lock contact blocks when the contact blocks are installed on the operators.

Specifications and other descriptions in this brochure are subject to change without notice.



IDEC CORPORATION

6-64, Nishi-Miyahara 2-Chome, Yodogawa-ku, Osaka 532-0004, Japan
Tel: +81-6-6398-2527, Fax: +81-6-6398-2547
E-mail: marketing@idec.co.jp

IDEC CORPORATION (USA)

1175 Elko Drive, Sunnyvale, CA 94089-2209, USA
Tel: +1-408-747-0550 / (800) 262-IDECE (4332)
Fax: +1-408-744-9055 / (800) 635-6246
E-mail: opencontact@idec.com

IDEC CANADA LIMITED

3155 Pepper Mill Court, Unit 4
Mississauga, Ontario, L5L 4X7, Canada
Tel: +1-905-890-8561, Toll Free: (888) 317-IDECE (4332)
Fax: +1-905-890-8562
E-mail: sales@ca.idec.com

IDEC AUSTRALIA PTY. LTD.

Unit 17, 104 Ferntree Gully Road,
Oakleigh, Victoria 3166, Australia
Tel: +61-3-8523-5900, Toll Free: 1800-68-4332
Fax: +61-3-8523-5999
E-mail: sales@au.idec.com

IDEC ELEKTROTECHNIK GmbH

Heselstruecken 8, 22453 Hamburg, Germany
Tel: +49-40-25 30 54 - 0, Fax: +49-40-25 30 54 - 24
E-mail: service@eu.idec.com

IDEC (SHANGHAI) CORPORATION

Room 701-702 Chong Hing Finance Center,
No. 288 Nanjing Road West, Shanghai 200003, PRC
Tel: +86-21-6135-1515
Fax: +86-21-6135-6225 / +86-21-6135-6226
E-mail: idec@cn.idec.com

IDEC (BEIJING) CORPORATION

Room 211B, Tower B, The Grand Pacific Building,
8A Guanghua Road, Chaoyang District,
Beijing 100026, PRC
Tel: +86-10-6581-6131, Fax: +86-10-6581-5119

IDEC (SHENZHEN) CORPORATION

Unit AB-3B2, Tian Xiang Building, Tian'an Cyber Park,
Fu Tian District, Shenzhen, Guang Dong 518040, PRC
Tel: +86-755-8356-2977, Fax: +86-755-8356-2944

IDEC IZUMI (H.K.) CO., LTD.

Unit G & H, 26/F., MG Tower, No. 133 Hoi Bun Road,
Kwun Tong, Kowloon, Hong Kong
Tel: +852-2803-8989, Fax: +852-2565-0171
E-mail: info@hk.idec.com

IDEC TAIWAN CORPORATION

8F-1, No. 79, Hsin Tai Wu Road, Sec. 1,
Hsi-Chih District, 22101 New Taipei City, Taiwan
Tel: +886-2-2698-3929, Fax: +886-2-2698-3931
E-mail: service@tw.idec.com

IDEC IZUMI ASIA PTE. LTD.

No. 31, Tannery Lane #05-01,
HB Centre 2, Singapore 347788
Tel: +65-6746-1155, Fax: +65-6844-5995
E-mail: info@sg.idec.com

IDEC ASIA (THAILAND) CO., LTD.

20th Fl., Sorachai Bldg., No.23/78,
Soi Sukhumvit 63, Sukhumvit Rd.,
Klongton-nua, Wattana, Bangkok 10110
Tel: +662-392-9765, Fax: +662-392-9768
E-mail: sales@th.idec.com

www.idec.com