

LOC		DIST		REVISIONS				
GP 00				ÄNDERUNGEN		DATE	DWN	APVD
PROJEKT NR.		ESEMNO3028		BESCHREIBUNG				
F	REVISED	PER	ECO-13-012712			10SEP2013	CJV	SLB
G	REVISED	PER	ECO-17-006044			10AUG2017	A.P	D.G

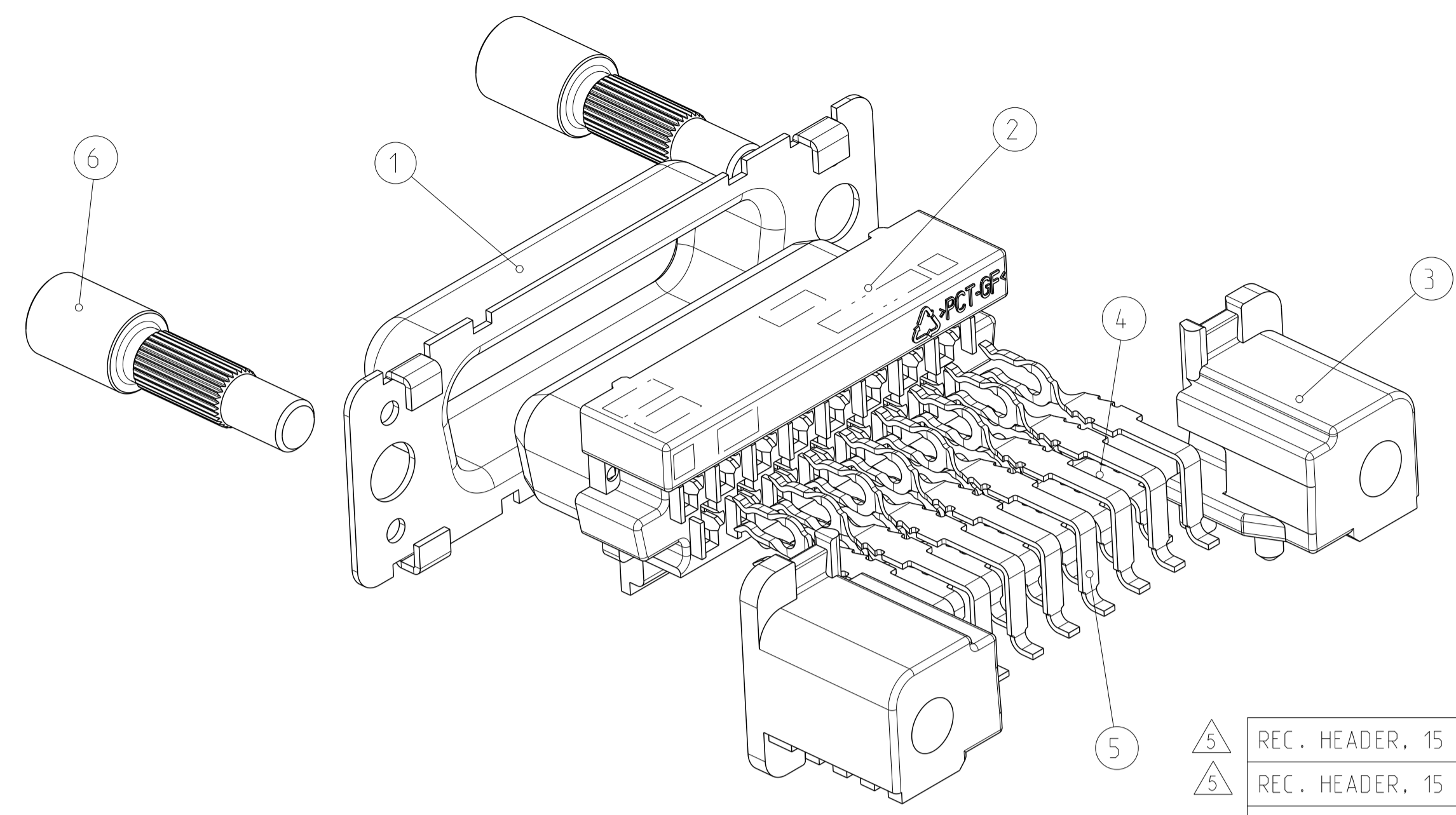

△	REC. HEADER, 15 POS., STUD WITH THREAD M3	4-1740196-2	4-1740196-5
△	REC. HEADER, 15 POS., BRACKET WITH THREAD M3	2-1740196-2	2-1740196-5
	REC. HEADER, 15 POS., STUD WITH THREAD UNC 4/40	3-1740196-2	3-1740196-5
	REC. HEADER, 15 POS., BRACKET WITH THREAD UNC 4-40	1-1740196-2	1-1740196-5
△	REC. HEADER, 15 POS., BRACKET WITH HOLE Ø3.1	0-1740196-2	0-1740196-5
	DESCRIPTION	SHELL PLATING: TIN OVER Ni	SHELL PLATING: Ni

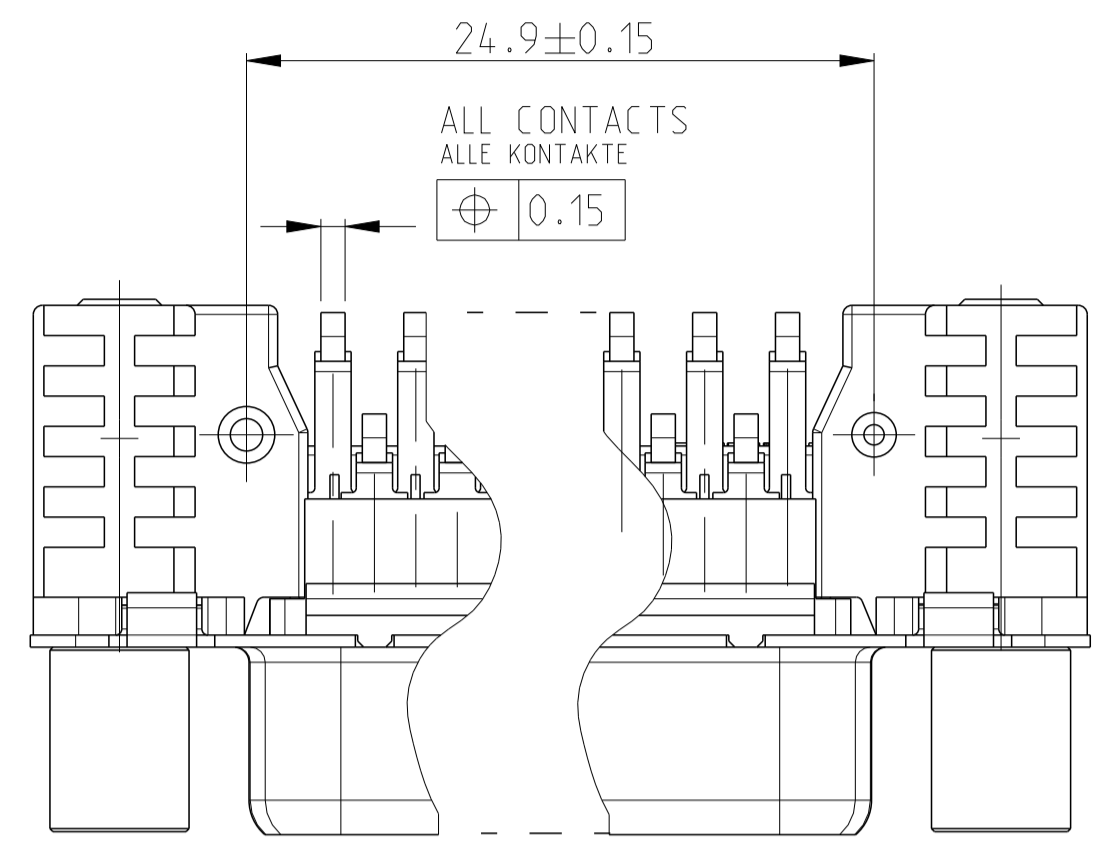
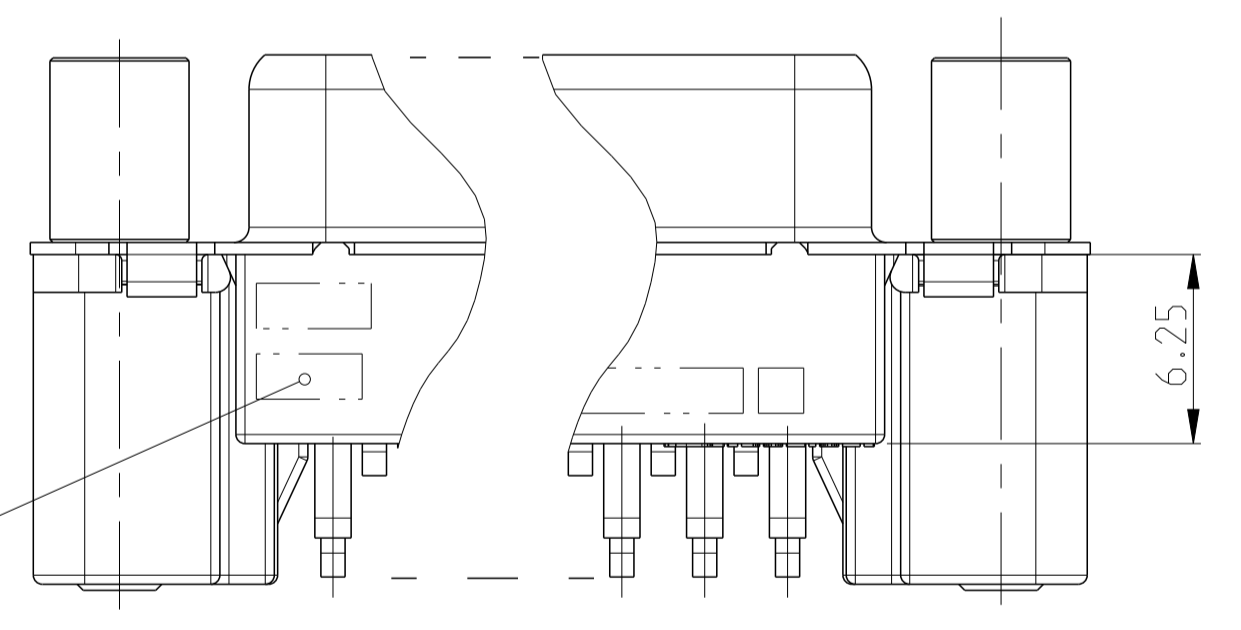
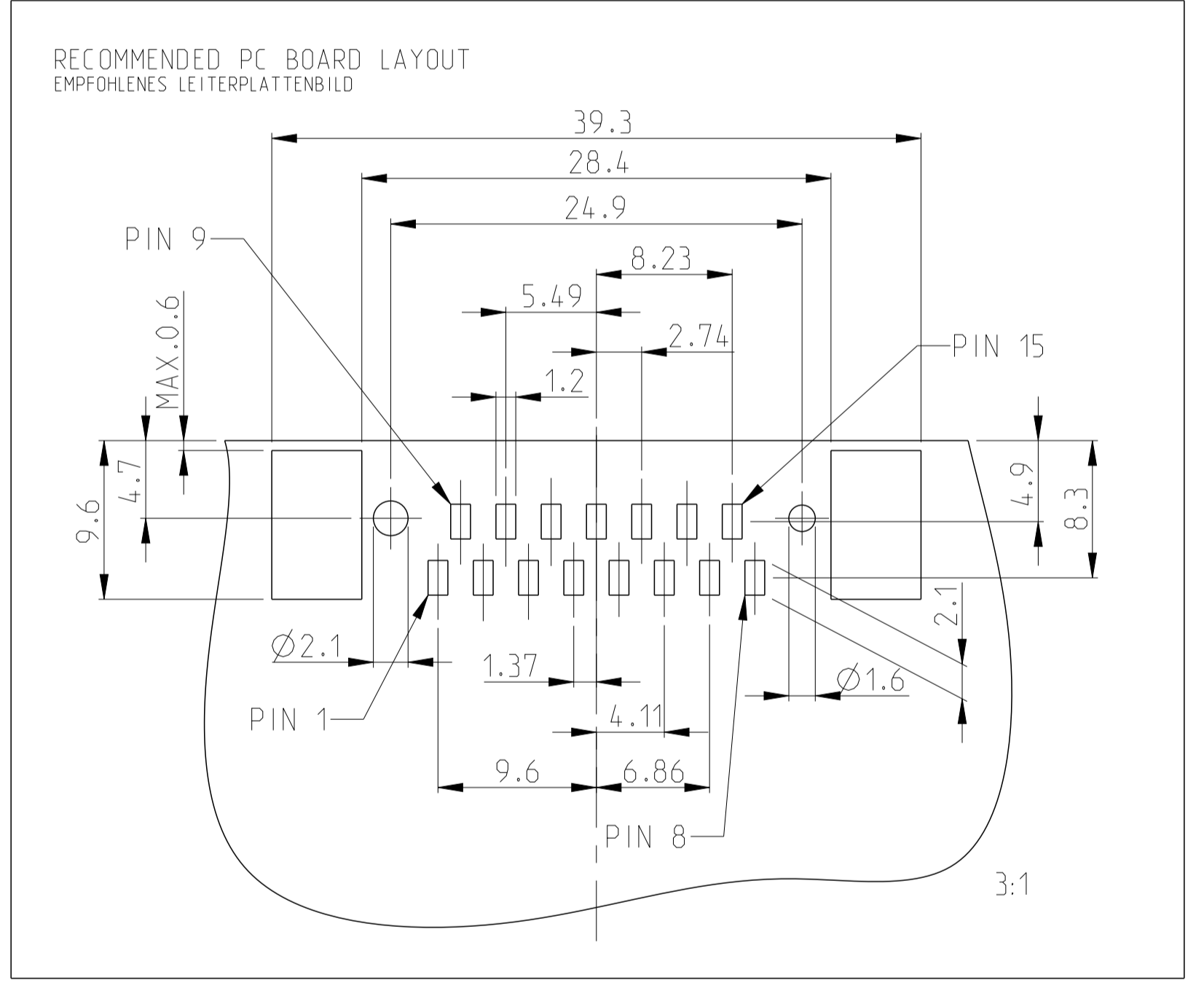
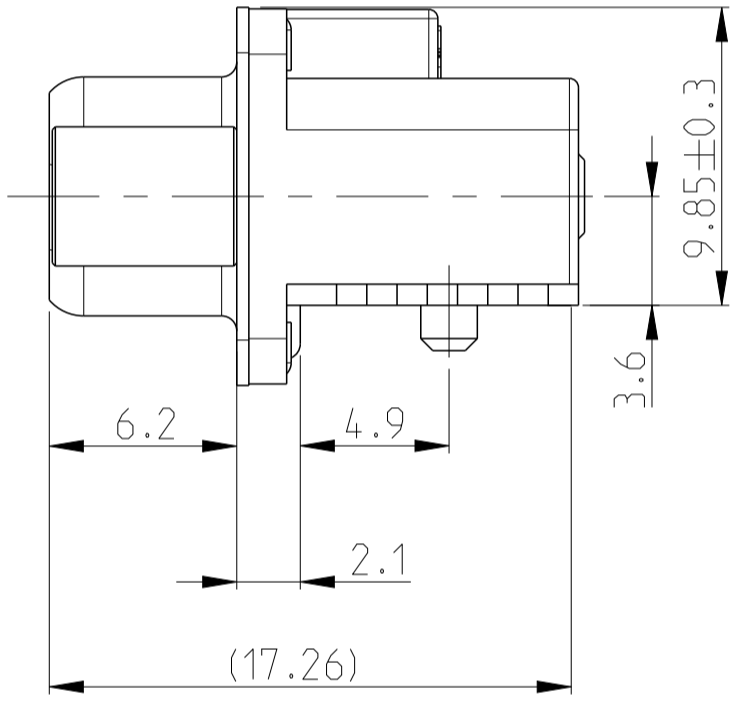
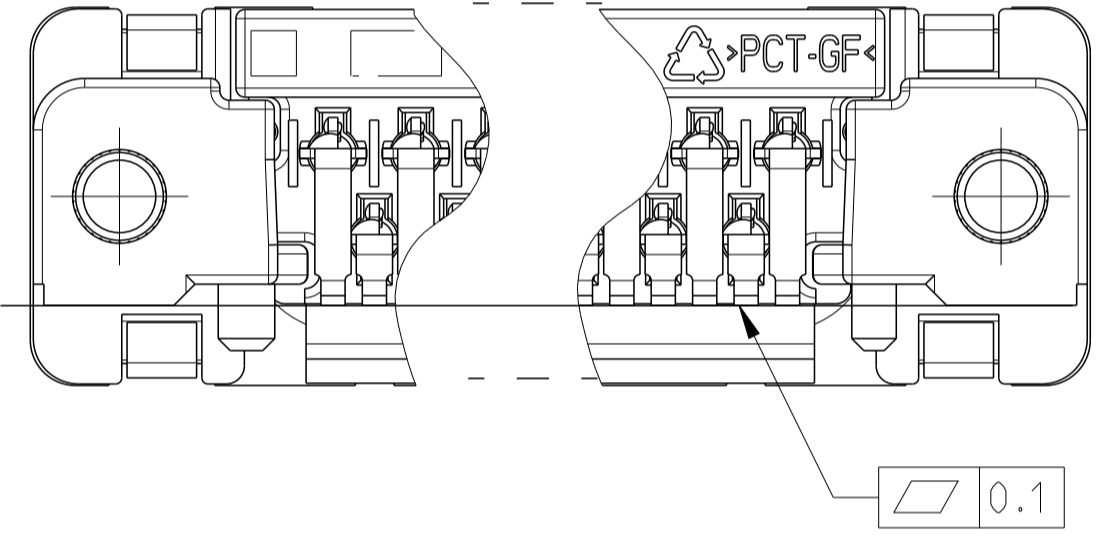

REMARKS:  
 △ CONTACT AREA: min. 0.8 µm Au OVER 1.27 µm Ni ;  
 SOLDER AREA: 3-5 µm Sn OVER min. 1.27 µm Ni  
 2 PACKAGING SEE SHEET 2  
 3 CONNECTOR SUITABLE FOR LEAD-FREE SMT SOLDER PROCESS  
 △ TIN OVER NICKEL  
 △ OBSOLETE

BEMERKUNGEN:  
 △ KONTAKTBEREICH: min. 0.8 µm Au UEBER 1.27 µm Ni ;  
 LOETBEREICH: 3-5 µm Sn UEBER min. 1.27 µm Ni  
 2 VERPACKUNGSART SIEHE BLATT 2  
 3 STECKER GEEIGNET FUER BLEIFREIES SMT LOETEN  
 △ ZINN UEBER NICKEL  
 △ UBERHOLT

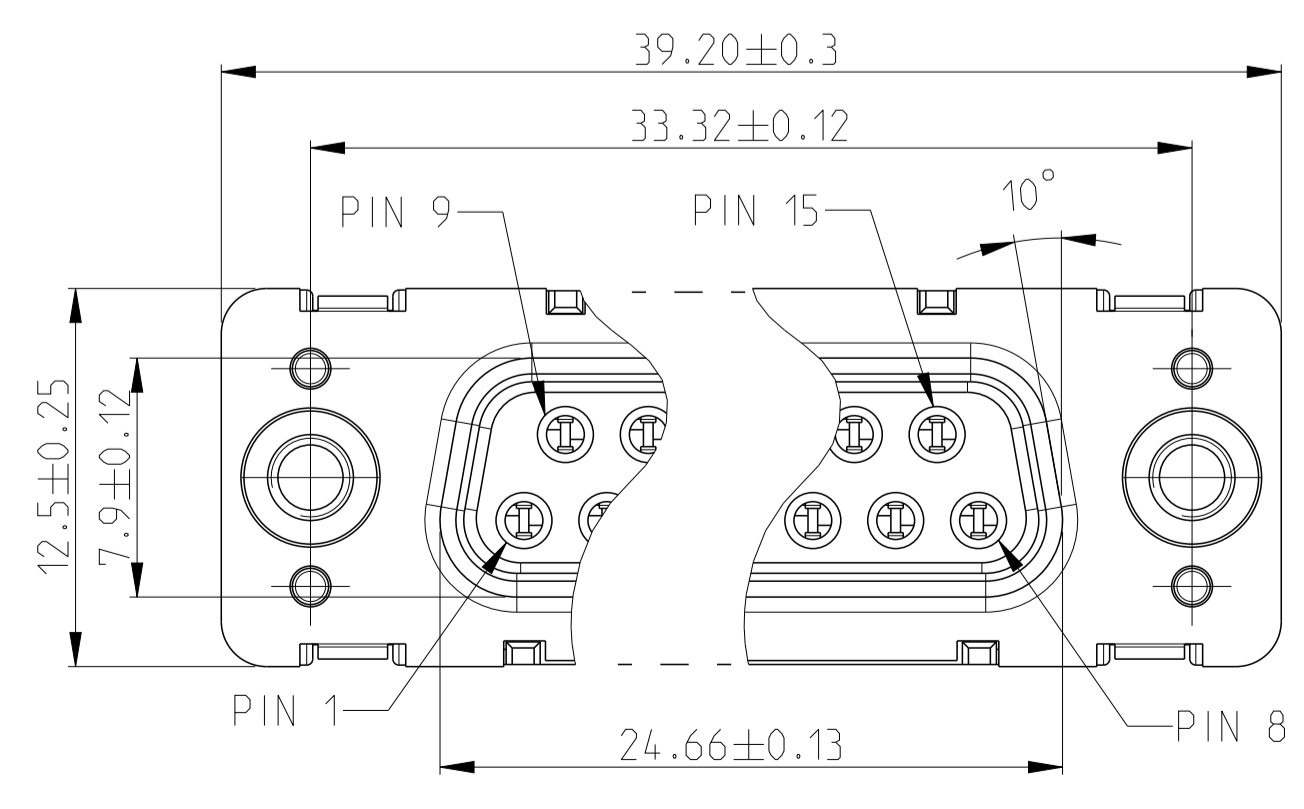

POS.	QTY.	DESCRIPTION BENENNUNG	SURFACE OBERFLAECHE COLOUR/FARBE	MATERIAL
6	2	THREAD STUD GEWINDEBOLZEN	NICKEL	STEEL STAHL
5	8	REC. CONTACT, SMD, LONG BUCHSENKONTAKT, SMD, LANG	△	CuMg
4	7	REC. CONTACT, SMD, SHORT BUCHSENKONTAKT, SMD, KURZ	△	CuMg
3	2	BRACKET, SMD, LEFT/RIGHT BUCHSENGEHAEUSE	△	CAST METAL DRUCKGUSS
2	1	REC. HOUSING SCHIRMBLECH	BLACK SCHWARZ	PCT-GF
1	1	SHELL	SEE TABLE SIEHE TABELLE	STEEL STAHL

THIS DRAWING IS A CONTROLLED DOCUMENT.  
 DIESER ZEICHNUNGSDRUCK IST EIN KONTROLLIERTES DOKUMENT.  
 ANFORDERUNG: DIESE ZEICHNUNG NUR FÜR DEN BESTIMMTEN ZWECK UND VERWENDUNG ZU VERWENDEN.  
 THE QUALITY CONTROL SYSTEM IS DESCRIBED IN THE DRAWING SPECIFICATION.

OWNER: L. SCHLUETER	DATE: 30NOV2004	NAME: HDP20 REC. HEADER, SMT, 15 POS. HDP20 BUCHSENSTECKER, SMT, 15 POL. EUROSTYLE
CHK: M. SCHAABSCHMIDT	DATE: 01DEC2004	SIZE: A1
APVD: G. FELDMEIER	DATE: 01DEC2004	CAGE CODE: 00779
PRODUCT SPEC: 108-94.000	APPLICATION SPEC:	SCALE: 4:1
WEIGHT: -	DRAWING NO: 1740196	SHEET 1 OF 2
MATERIAL: SEE TABLE S-TABELLE	FINISH/SCHLUESSELFARBE: SEE TABLE S-TABELLE	CUSTOMER DRAWING

STE TE Connectivity

LOC		DIST		REVISIONS			
P	LTN	DESCRIPTION	DATE	DMN	APVD		
-	-	SEE SHEET 1	-	-	-		

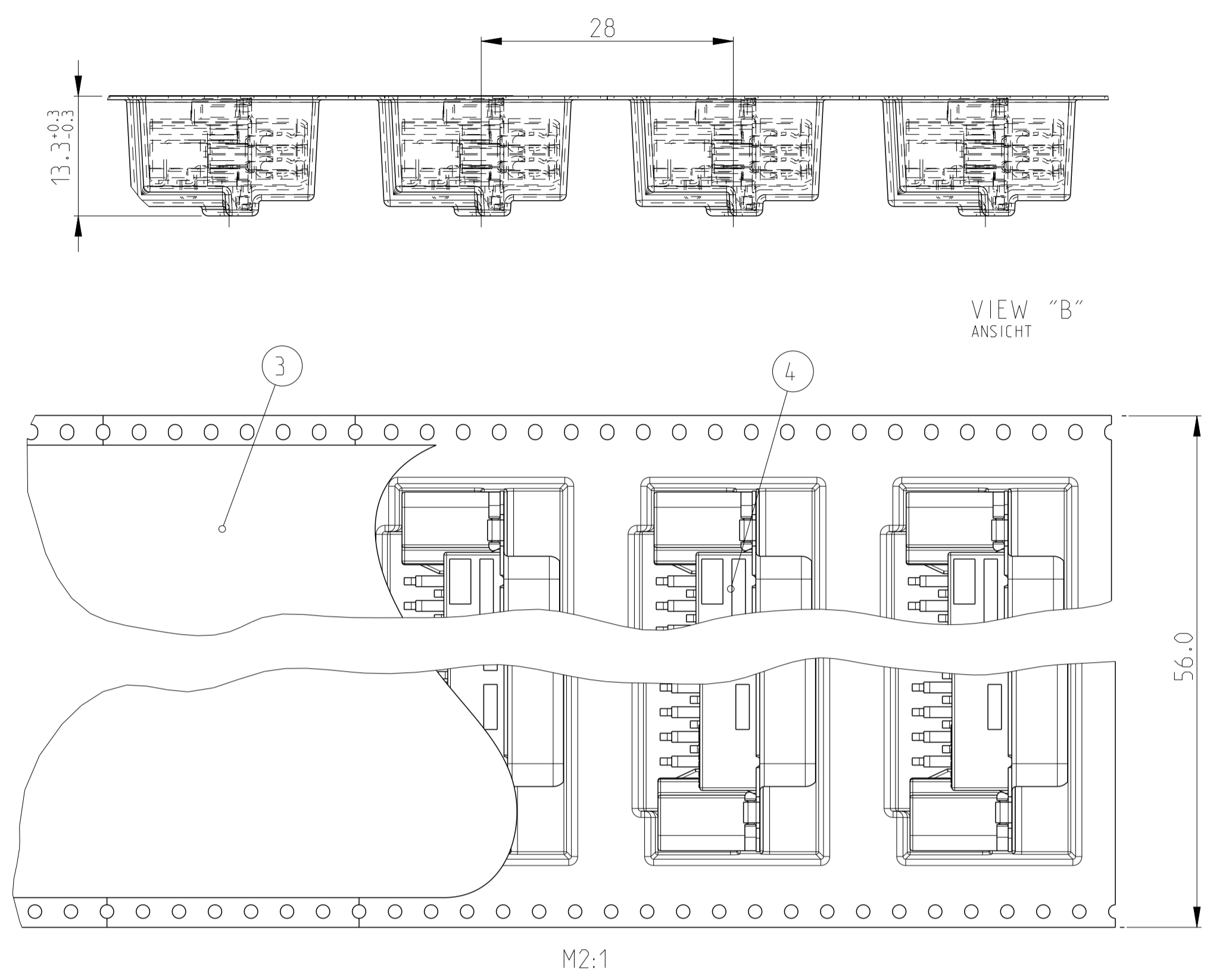
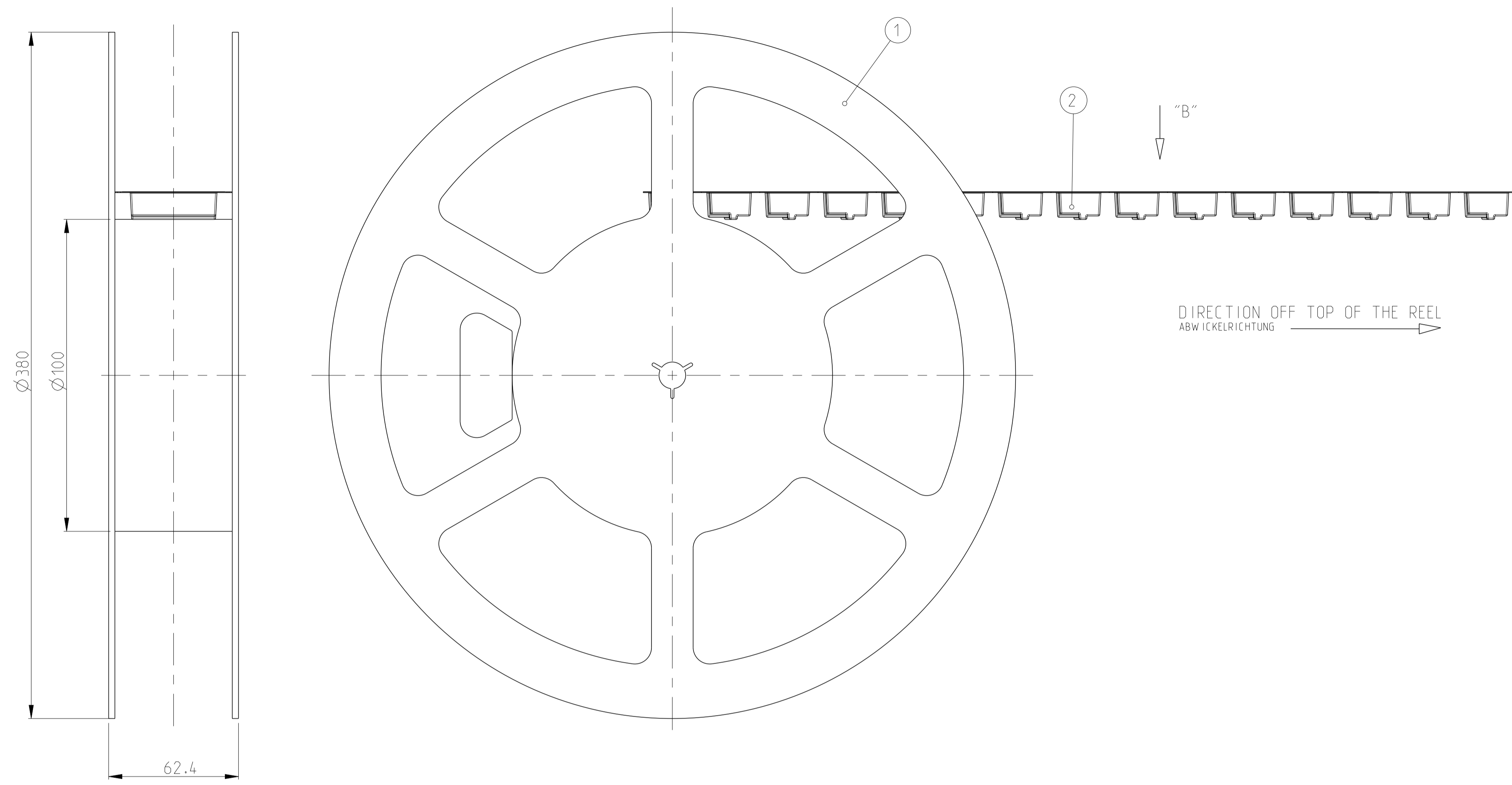

**REMARKS:**

- COVER TAPE WITH BLISTER BELT WELDED OR PASTED
  - BLISTER BELT, COVER AND TAPE ACC. TO DIN/IEC 286 PART 3
  - FIRST AND LAST RUNNING OF THE CARRIER TAPE ACC. TO DIN/IEC 286 PART 3
  - 7m BLISTERBELT AND 7.1m COVER TAPE, 225 LOOSE PIECE PARTS
- ⚠ OBSOLETE

**BEMERKUNGEN:**

- ABDECKBAND MIT BLISTERGURT VERSCHWEISST ODER VERKLEBT
  - BLISTERGURT, ABDECKBAND UND REEL NACH DIN/IEC 286 TEIL 3
  - VOR- UND NACHLAUF AM BLISTERGURT NACH DIN/IEC 286 TEIL 3
  - 7m BLISTERGURT UND 7.1m ABDECKBAND, 225 EINZELTEILE
- ⚠ UBERHOLT

ORDER NO. BESTELL-NR.	POS.	PARTS					DESCRIPTION BENENNUNG	SURFACE OBERFLAECHE COLOUR/FARBE	MATERIAL
		4-1740196-5	3-1740196-5	2-1740196-5	1-1740196-5	0-1740196-5			
1740196	4	225	-	-	-	-	SUB-D REC. HEADER, 15 POS., STUD M3 SUB-D BUCHSENSTECKER, 15 POL., BOLZEN M3	-	-
	4	-	225	-	-	-	SUB-D REC. HEADER, 15 POS., STUD UNC4-40 SUB-D BUCHSENSTECKER, 15 POL., BOLZEN UNC4-40	-	-
	4	-	-	225	-	-	SUB-D REC. HEADER, 15 POS., M3 SUB-D BUCHSENSTECKER, 15 POL., M3	-	-
	4	-	-	-	225	-	SUB-D REC. HEADER, 15 POS., UNC4-40 SUB-D BUCHSENSTECKER, 15 POL., UNC4-40	-	-
	4	-	-	-	-	225	SUB-D REC. HEADER, 15 POS. SUB-D BUCHSENSTECKER, 15 POL.	-	-
	3	7.1m	7.1m	7.1m	7.1m	7.1m	COVER BELT FOR BLISTER BELT ABDECKBAND FUER BLISTERGURT	TRANSPARENT	PET
	2	7m	7m	7m	7m	7m	BLISTER BELT BLISTERGURT	GREY/BLACK GRAU/SCHWARZ	PS
1	1	1	1	1	1	REEL SPULE	GREY GRAU	PS	

THIS DRAWING IS A CONTROLLED DOCUMENT. DIMENSIONS: mm. TOLERANCES UNLESS OTHERWISE SPECIFIED: 0 PLC #, 1 PLC #, 2 PLC #, 3 PLC #, 4 PLC #, ANGLES #°. MATERIAL: SEE TABLE S-TABELLE. FINISH: SEE TABLE S-TABELLE.

OWN: L. SCHLUETER, 30NOV2004. CHG: M. SCHAARSCHEMIDT, 01DEC2004. APVD: G. FELDMEIER, 01DEC2004. PRODUCT SPEC: 108-94.000. APPLICATION SPEC: -.

NAME: HDP20 REC. HEADER, SMT, 15 POS. HDP20 BUCHSENSTECKER, SMT, 15 POL. EUROSTYLE. SIZE: A1. CAGE CODE: 00779. DRAWING NO: 1740196. WEIGHT: -. CUSTOMER DRAWING: -.

TE Connectivity. SCALE: 1:1. SHEET: 2 OF 2. REV: G.