

PART NAME

NEMA 4X DIE-CAST ALUMINUM BOX w/MTG. BRKTS.

PART No.

AN-2854 & AN-2854-B

REVISION DATE

11-15-11

MATERIAL: ALUMINUM ALLOY #ADC-12

FINISH: NATURAL (NO SUFFIX)
SMOOTH BLACK (SUFFIX -B)

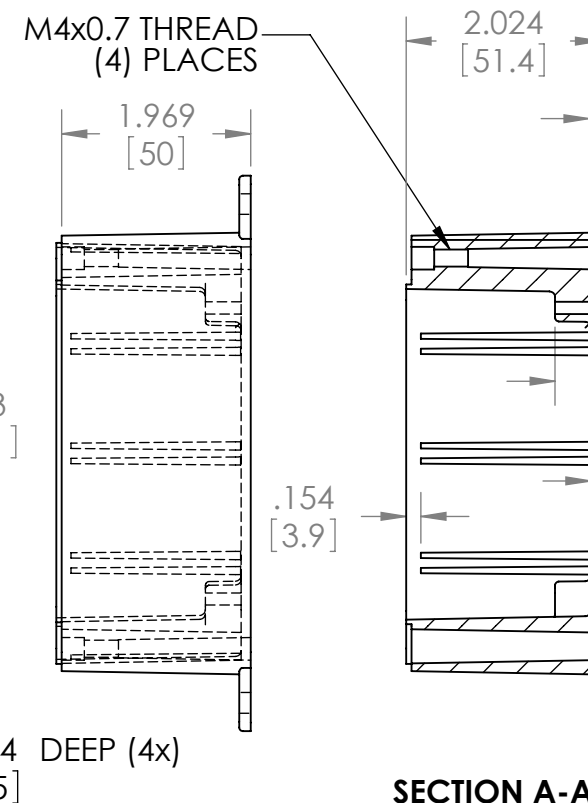
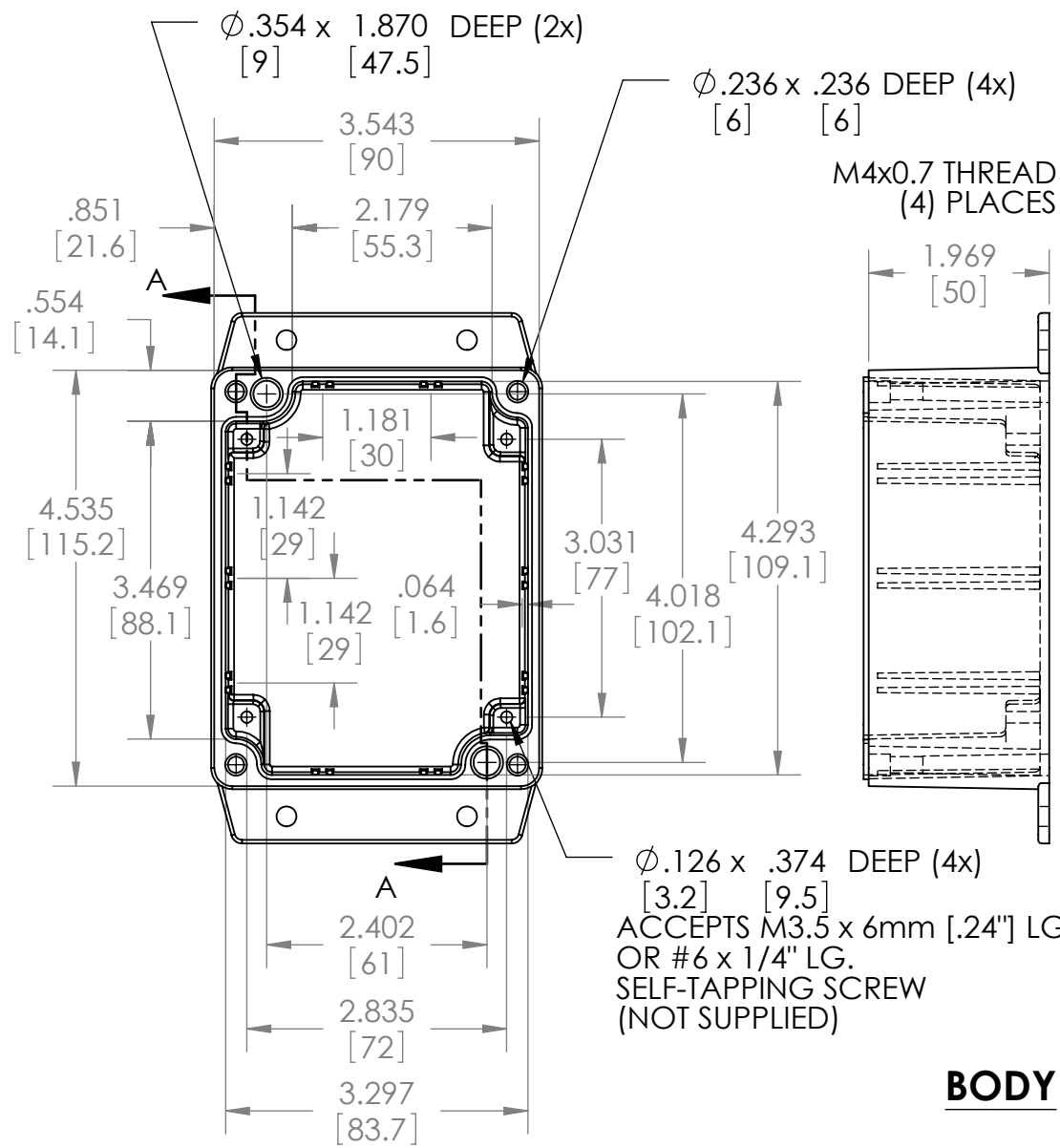

BODY

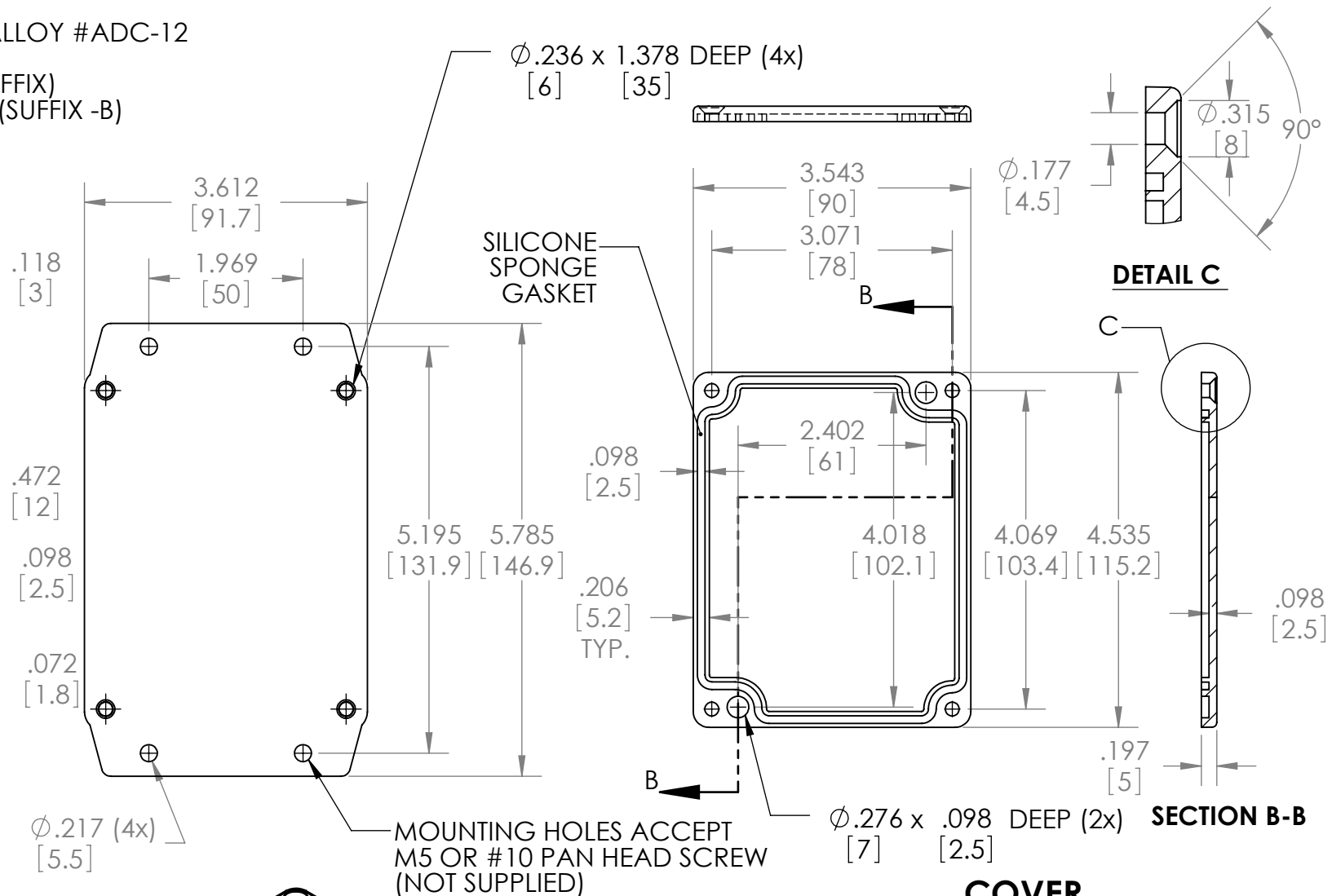

COVER

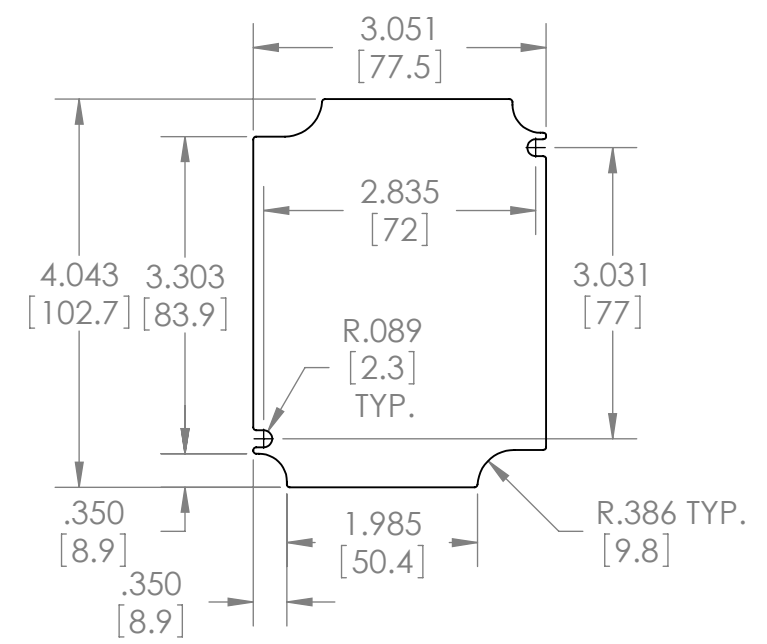
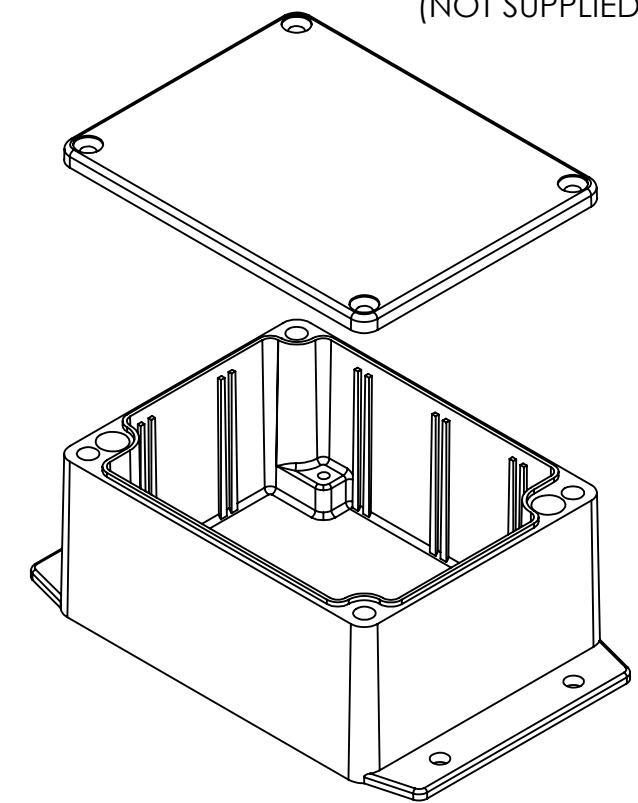

NOTES:

- 1.) FOUR (4) M4x0.7 x 20mm (.79") LG. CSK. HEAD STAINLESS STEEL SCREWS SUPPLIED FOR ASSEMBLY OF COVER TO BODY.
- 2.) ALL HOLE DIAMETERS HAVE $\pm .005$ [$\pm .13$] TOLERANCE
ALL OTHER DIMENSIONS HAVE $\pm .015$ [$\pm .38$] TOLERANCE
- 3.) ALL OUTSIDE AND INSIDE DRAFT ANGLE: 1°