

PSE1000PFC

1100 Watts
PFC Front End

Total Power: 1100 Watts
#of Outputs: Single
Output: 390Vdc



Special Features

- 1100 W output power
- Unity power factor correction
- 3.5"x2.4"x1"
- 119 Watts per cubic inch
- Industrial Safety
- -40 °C to 85 °C
- High efficiency: 94% typical
- Negative enable function
- Output OTP, OVP and power limit
- MIL-STD-810F for shock and vibration
- Current sharing and monitoring

Compliance

- EMI Class B
(with external EMI filter)
- EN61000 Immunity
(with external EMI filter)
- RoHS 2

Safety

- UL 60950-1
508/1598/1433
60601-1 ed 3
- cUL 60950-1
- TUV 60950-1
60601
- CB Scheme Report/Cert

Product Descriptions

The PSE1000PFC Power Factor Correction module is part of advanced High Density modular power supply components. Featuring high reliability and convenient control and monitoring functions, these modules are designed to reduce product development time and enhance system performance. The PFC module is designed to work over all typical line voltages used worldwide, and provide unity power factor with very low levels of harmonic distortion in line current.

Model Number

Model Number	Output Voltage (V)	Minimum Load (A)	Maximum Load ¹ (A)	Output Ripple P/P ² @ 0-50°C	Maximum Continuous Power ³ (P _{O,max})	Safety Approval ⁴
PSE1000PFC	390	0	2.82	<50V	1100W	See Note 4 below

Note 1 - Load will be controlled by LD_EN signal for all input conditions. Load will be loaded when LD_EN is high, and load will be removed when LD_EN is low. The load current ramp will be no more than 1A/us.

Note 2 - Output ripple measured at the end of the output cable terminated with 10uF aluminum electrolysis cap in parallel with 0.1uF ceramic capacitor.

Note 3 - The maximum continuous average output power from this power supply shall be 1100W.

Note 4 - Safety Approvals:

- (A) UL+cUL 60950-1
- (B) UL 60601-1
- (C) TUV 60950-1
- (D) TUV 60601
- (E) CB Scheme Report/Cert

Options

None

Electrical Specifications

Absolute Maximum Ratings

Stress in excess of those listed in the ‘Absolute Maximum Ratings’ may cause permanent damage to the power supply. These are stress ratings only and functional operation of the unit is not implied at these or any other conditions above those given in the operational sections of this TRN. Exposure to any absolute maximum rated condition for extended periods may adversely affect the power supply’s reliability.

Table 1. Absolute Maximum Ratings:

Parameter	Model	Symbol	Min	Typ	Max	Unit
Input Voltage: AC continuous operation	PSE1000PFC	$V_{IN,AC}$	90	-	264	Vac
Maximum Output Power	PSE1000PFC	$P_{O,max}$	-	-	1100	W
Isolation Voltage: Input to Chassis	PSE1000PFC		-	-	1500	Vac
Operating Temperature	PSE1000PFC	T_A	-40 ¹	-	+85 ²	°C
Storage Temperature	PSE1000PFC	T_{STG}	-40 ³	-	+100 ³	°C
Humidity Operating (Non-condensing) Non-operating (Condensing)	PSE1000PFC		10 10	- -	100 100	% %
Altitude Operating Storage	PSE1000PFC		-500 -1000	- -	13,000 ⁴ 50,000	feet feet

Note 1 - Ambient Temperature at full load

Note 2 - Baseplate Temperature at full load (Output derating applies from 85 °C to 100 °C Baseplate Temperature operation)

Baseplate temperature is average temperature of the five measure points shows right. The supply could work at -40 °C ambient temperature for all input conditions. The supply could work at up to 85 °C baseplate temperature for $V_{in} \geq 100V_{ac}$. For input voltage is lower than 100Vac, the supply could work at 85 °C with no more than 1000W output power.

Note 3 - Ambient Temperature is the same with Baseplate Temperature

Note 4 - Derating 1°C Per 1000 feet above 10,000 feet.

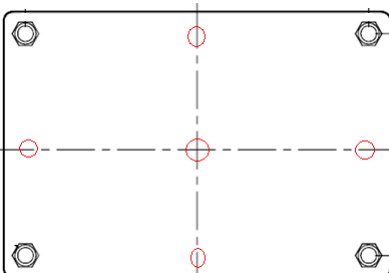

Input Specifications

Table 2. Input Specifications:

Parameter	Conditions	Symbol	Min	Typ	Max	Unit
Operating Input Voltage, AC	All	V_{IAC}	90	115/230	264	$V_{AC_{RMS}}$
Input Vac Source Frequency	All	f_{IAC}	47	50/60	63	Hz
Maximum Input Current ($I_O = I_{O,max}$)	$V_{IAC} = 90V_{AC}$	$I_{I,max}$	-	-	13	A_{RMS}
No Load Input Current (V_O On, $I_O = 0A$)	$V_{IAC} = 90V_{AC}$	I_{I,no_load}	-	-	200	mA_{RMS}
Harmonic Line Currents	Nominal Input Conditions	THD	Per ANSI C82.11-1993.			
Power Factor	$V_{IAC} = 115V_{AC}/230V_{AC}$ 25% to 100% load @47-63Hz	PF	0.9	-	-	
	$V_{IAC} = 120V_{AC}$ 100% load @47-63Hz	PF	0.97	-	-	
Startup Surge Current (Inrush) at 230Vac @ 25°C (with external resistor from INRUSH pin to OUTPUT-)	$V_{IAC} = 230V_{AC}$	-	-	-	50	A_{PK}
Isolation – Input to Chassis	All	-	-	1500	-	Vac
Leakage Current to earth ground	$V_{IAC} = 230V_{AC}$ $f_{IAC} = 50/60$ Hz	-	-	-	275	μA
PFC Switching Frequency	All	$f_{SW,PFC}$	49	-	52	KHz
Operating Efficiency @ 25°C	$I_O = I_{O,max}$ $V_{IAC} = 230V_{AC}$	η	94	-	-	%
Turn On Delay: Resistive Load	$V_{IN,AC} = 90V_{AC}$ $I_O = I_{O,max}$	$t_{turn-On}$	-	-	2000	mSec
System Stability: Phase Margin Gain Margin	-	-	45 10	-	-	\emptyset dB

Output Specifications

Table 3. Output Specifications:

Parameter	Condition	Symbol	Min	Typ	Max	Unit
Output Regulation	Inclusive of set-point, temperature change, warm-up drift and dynamic load	V_O	380	390	400	V
Output Power	All	P_o	-	-	1100	W
Output Ripple, pk-pk	Measure with a 0.1uF ceramic capacitor in parallel with a 10uF tantalum capacitor, 0 to 20MHz bandwidth	V_o	-	-	50	V_{PK-PK}
Output Current	All	I_o	0	-	2.82	A
V_O Load Capacitance ¹	Start up		330	680	1000	uF
V_O Dynamic Response	50% load change, slew rate = 1A/us	Peak Deviation	-	-	5	%
		Settling Time	-	-	500	uSec
V_O Long Term Stability Max change over 24 hours	After thermal equilibrium (30 mins)	$\pm\%V_O$	-	-	1	%
Hold up time	Input:115Vac/50Hz, Output:390V/2.82A, Measure with 2 x 330uF/450V bulk capacitors across the DC output.		16	-	-	ms

Note 1 - Unless otherwise specified, all of the outputs will have 680uF/450V electrolytic capacitor.

System Timing Specifications

Table 4. System Timing Specifications:

Label	Parameter	Min	Typ	Max	Unit
T1	Delay from AC being applied to V_o being within regulation	-	-	1000	mSec
T2	V_o rise time, 0V to V_o in regulation.	5	-	50	mSec
T3	Delay from AC being applied to output voltages being within regulation with LD_EN asserted high.	-	-	2000	mSec
T4	Hold up time - time all voltages stay within regulation after loss of AC.	16	-	-	mSec
T5	Delay from loss of AC to de-assertion of LD_EN.	11	-	-	mSec
T6	Delay from LD_EN de-asserted to output voltages dropping out of regulation limits.	1	-	-	mSec

System Timing Specifications

Figure 1. System Timing Diagram:

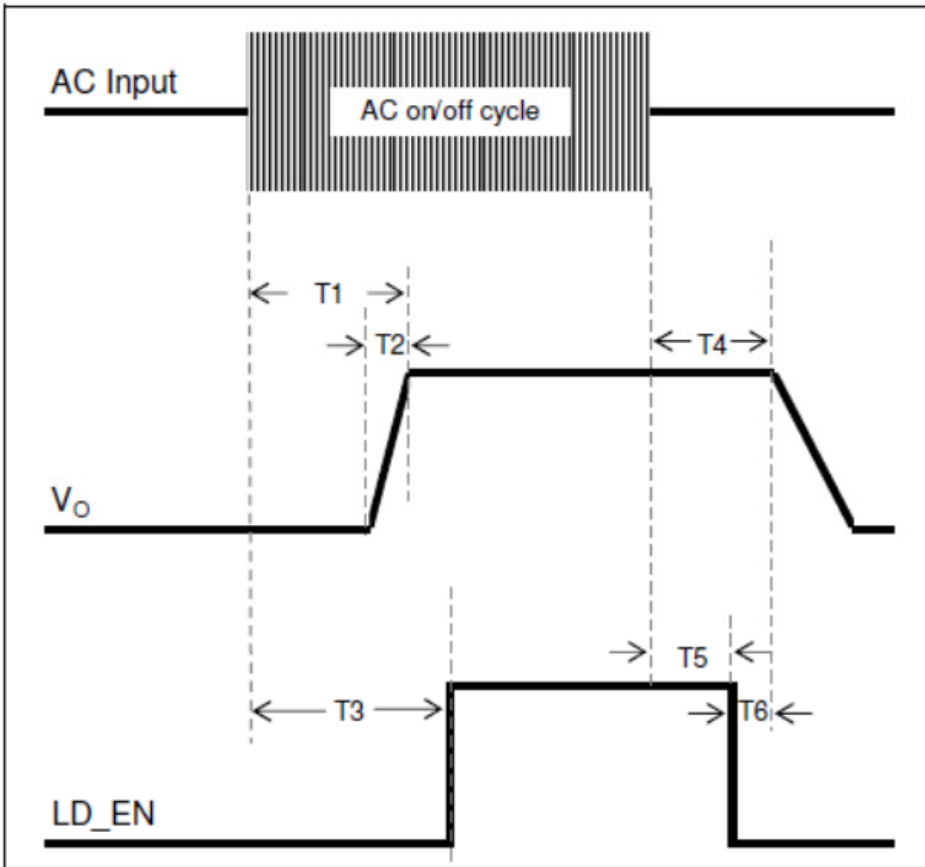

PSE1000PFC Performance Curves

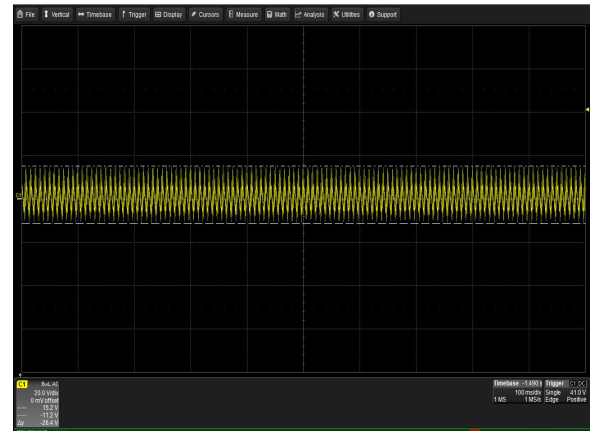
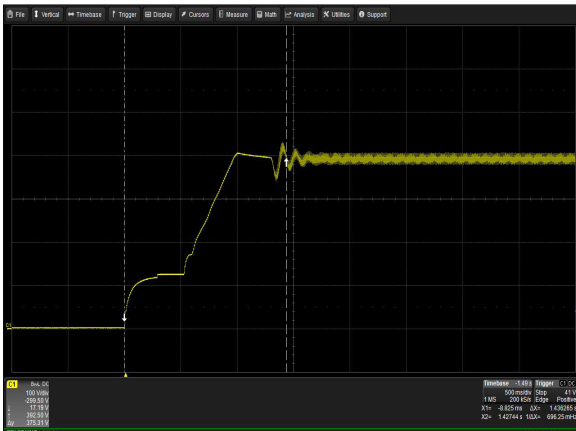
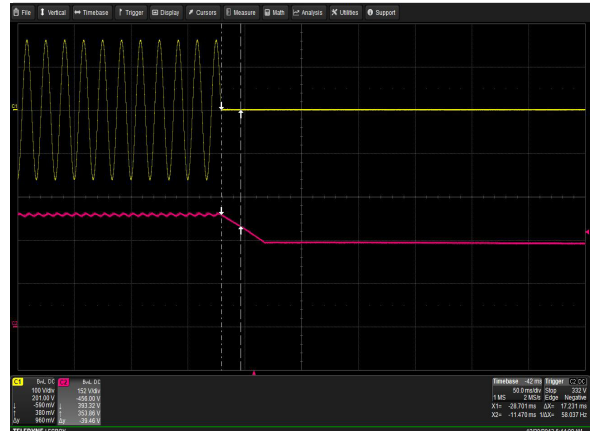

PSE1000PFC Performance Curves

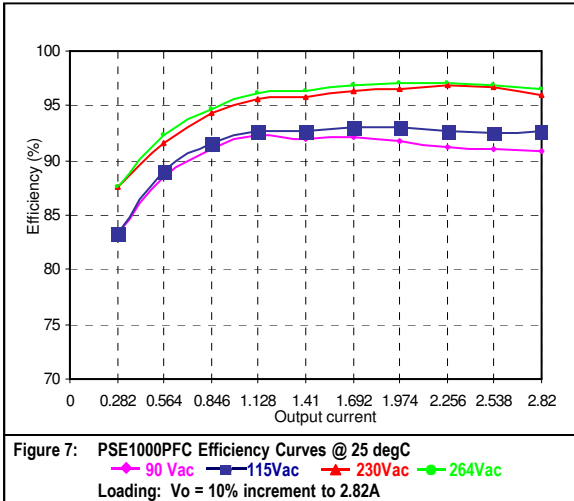

Protection Function Specification

Over Voltage Protection (OVP)

The overvoltage point is between 107% and 115% of typical output voltage 390V. The power supply latches off during output over voltage with the AC line recycled to reset the latch.

Parameter	Min	Nom	Max	Unit
Output Overvoltage	420	/	450	V

Over Current Protection (OCP)

The power supply PSE1000PFC includes internal current limit circuitry to prevent damage in the event of overload or short circuit. It should shut down in bouncing mode in case of the over current condition. Recovery is automatic when the overload is removed. The OCP range is defined shall be not exceed 160% of 1000W full load (2.56A) at any condition.

Parameter	Min	Nom	Max	Unit
Output Overcurrent	3.3	/	4.1	A

Over Temperature Protection (OTP)

The power supply is internally protected against over baseplate temperature (102 °C – 107 °C) conditions. The OTP mode is shut down and automatically restart when fault is removed. The recover baseplate temperature is 92 °C – 97 °C.

No Load protection

The power supply will not suffer damage if any or all outputs have no load.

Mechanical Specifications

Mechanical Outlines

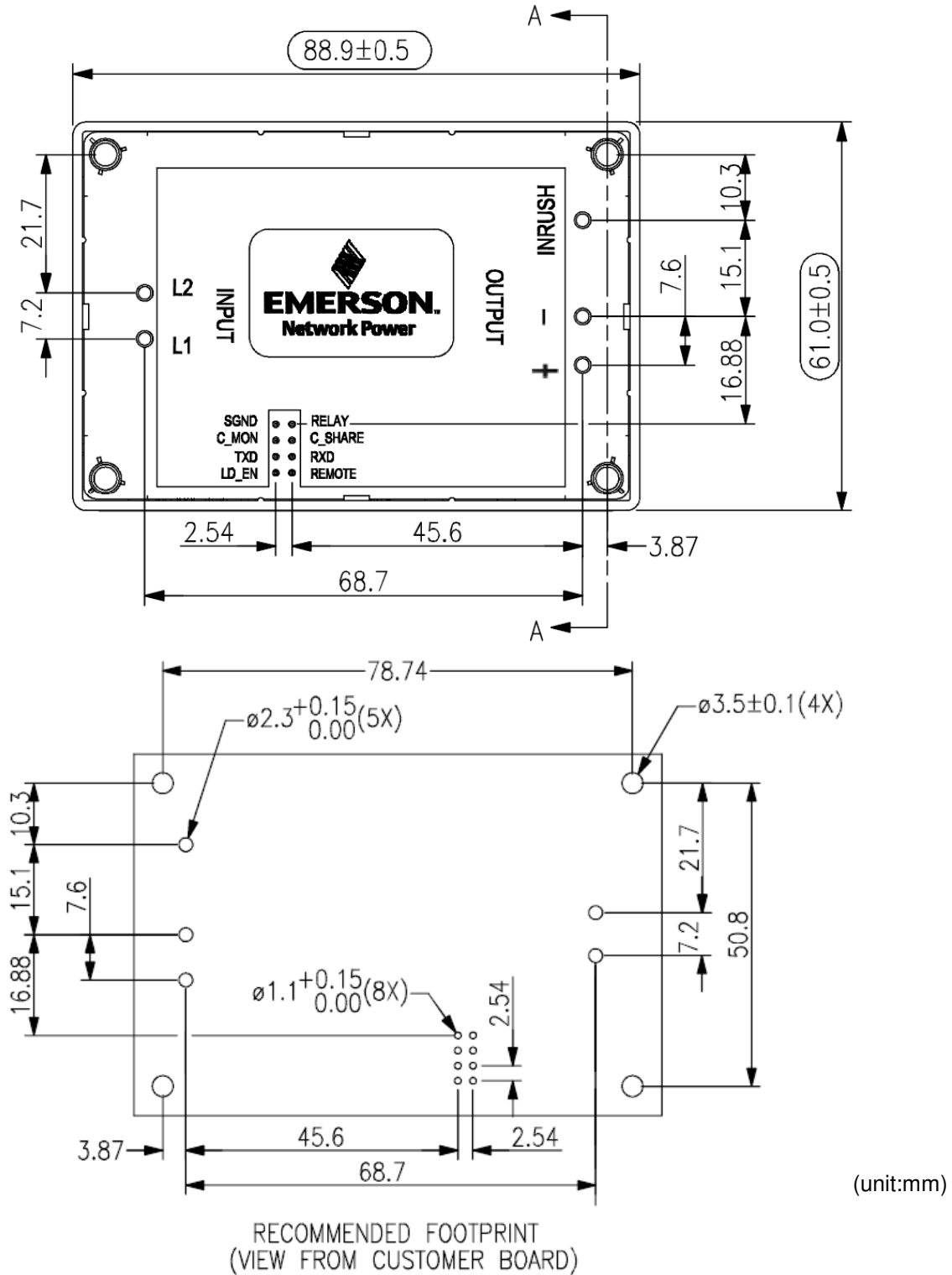

Mechanical Specifications

Mechanical Outlines

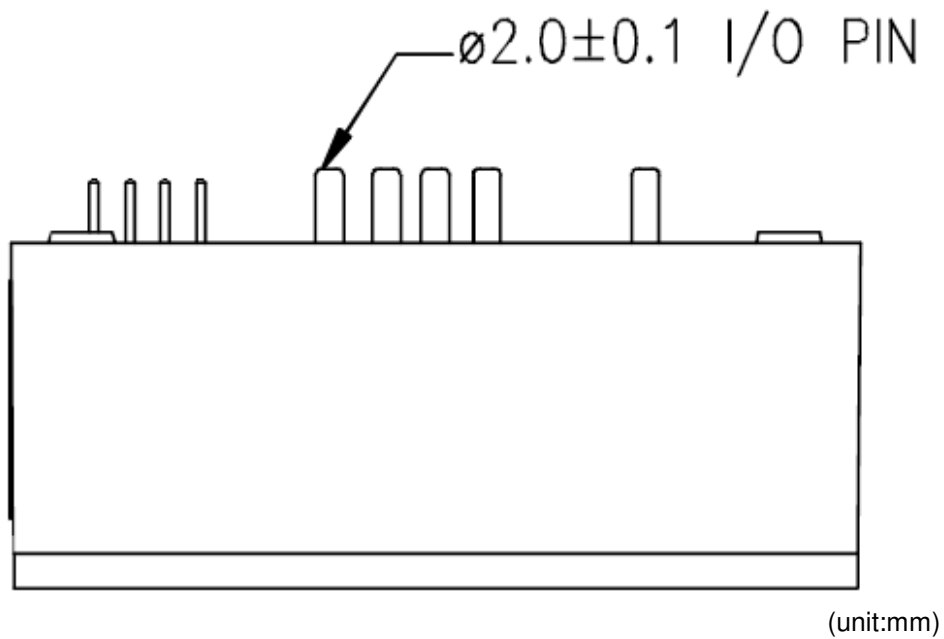
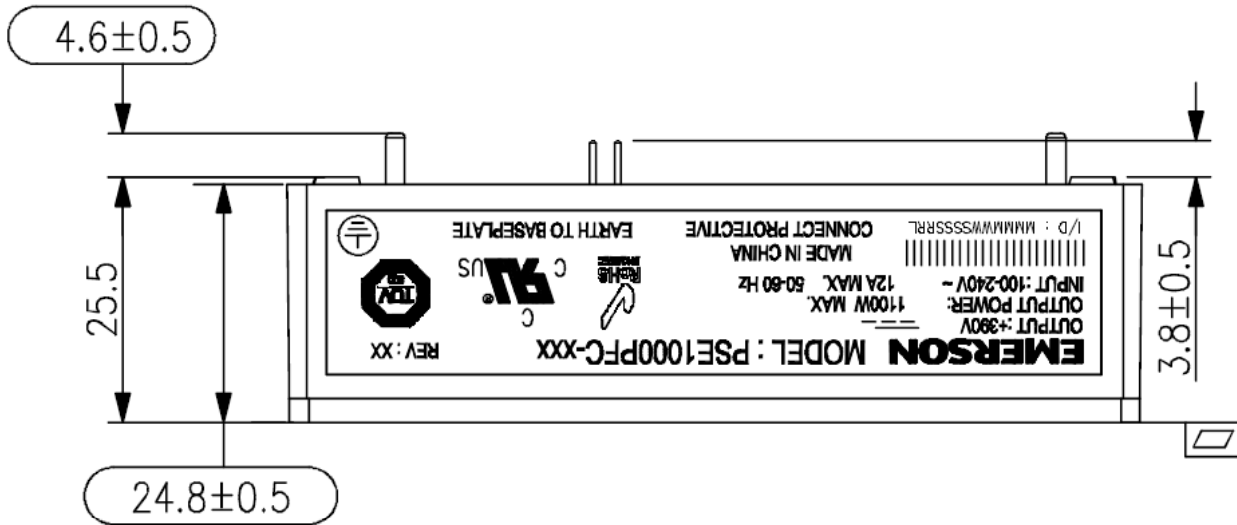

Mechanical Specifications

Mechanical Outlines

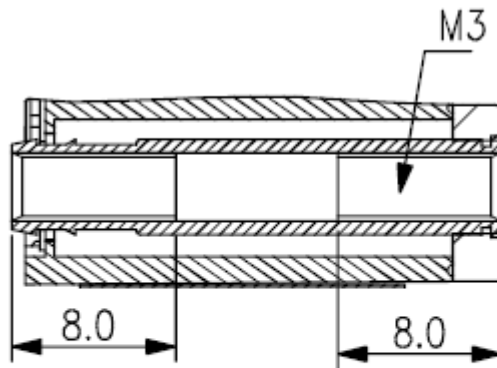
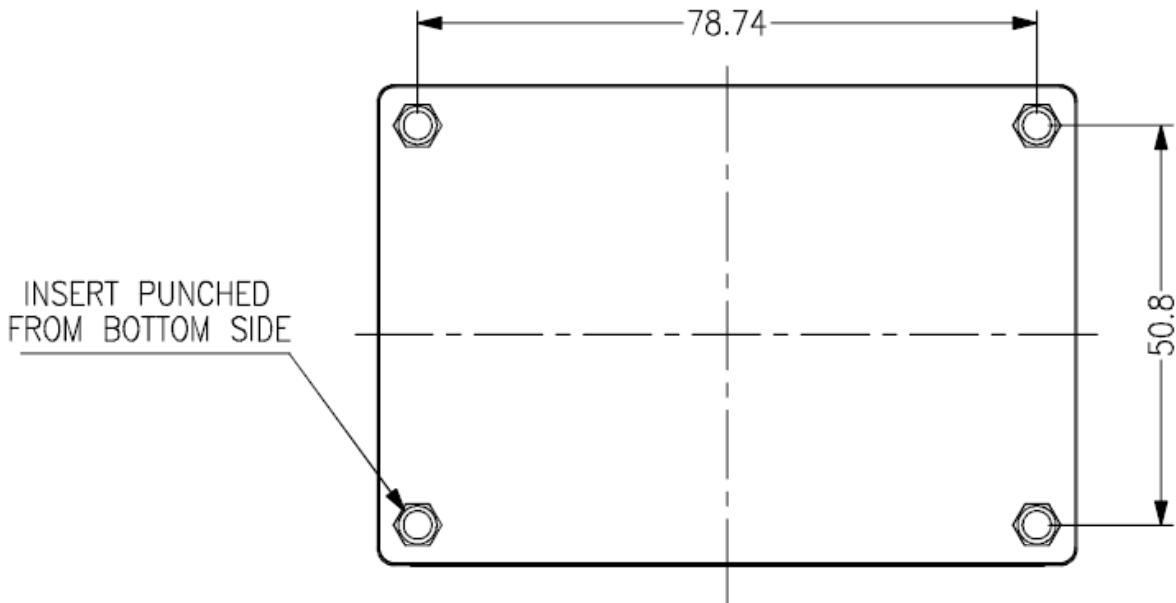

SECTION A-A
SCALE 2.000

(unit:mm)

Pin Definitions

Table 5. Pin Definitions:

Pin	Length	Diameter	Designation	Definitions
AC Input Pin	L1 = 4.6 ± 0.5 mm	Φ2.0±0.1 mm	L1	Line
			L2	Neutral
			INRUSH	Limit Inrush Current
DC Output Pin	L2 = 4.6 ± 0.5 mm	Φ2.0±0.1 mm	OUTPUT+	DC Output+
			OUTPUT-	DC Output-
Control Pin	L3 = 3.8 ± 0.5 mm	Φ1.1+0.15/-0.00 mm	S GND	Signal Ground
			RELAY	Control the relay out of the unit to short the inrush resistor
			C_MON	Current monitoring
			C_SHARE	For active load sharing when the units in parallel
			TXD	Digital communication for transmitting data to an external device
			RXD	Digital communication for receiving data for the internal MCU
			LD_EN	Load enable
REMOTE	Remote ON/OFF			

Weight

The PSE1000PFC series weight is 0.88 pounds (0.4kg) maximum.

Environmental Specifications

EMC Immunity

PSE1000PFC power supply (with external EMI filter) is designed to meet the following EMC immunity specifications:

Table 6. Environmental Specifications:

Document	Description
FCC Part 15 Subpart J Class B	conducted and Class B with a ground plane for radiated interference(with 6db margin)
VCCI	Class II
EN 61000-4-2	ESD up to 4KV contact, 8KV discharge, performance Criteria B
EN 61000-4-3	RFI 3V/m
EN 61000-4-4	Electrical Fast Transients level 3 minimum
EN 61000-4-5	Surge level 3 minimum
EN 61000-4-6	Radio frequency common mode, Levels 3V (rms) Modulated AM 80%. 1 kHz, 150 ohm source impressed
EN 61000-4-8	Power Frequency Magnetic Immunity, 1 A/m.
EN 61000-4-11	AC Input transients [Reference EN 60601-1:2001]
EN 61547	Specification for equipment for general lighting purposes/ EMC immunity requirements

Safety Certifications

The PSE1000PFC power supply is intended for inclusion in other equipment and the installer must ensure that it is in compliance with all the requirements of the end application. This product is only for inclusion by professional installers within other equipment and must not be operated as a stand alone product.

Table 7. Safety Certifications for PSE1000PFC series power supply system

Document	Description
UL+CUL: UL60950-1 2nd Ed;	US and Canada Requirements
CSA C22.2 No. 60950-1-07, 2nd Ed	Information Technology Equipment - Safety - Part 1: General Requirements (Bi-National standard, with UL 60950-1)
TUV or VDE/EN60950: IEC 60950-1:2005 (2nd Ed); Am1:2009, EN 60950-1:2006/A11:2009/A1:2010/A12:2011	European Requirements
CB Certificate and Report	All CENELEC Countries
CE mark: EN 60950-1/A12:2011	LVD+RoHS

EMI Emissions

The PSE1000PFC and PSE1000DCDC-12V series has been designed to comply with the Class B (with external EMI filter before PFC module) limits of EMI requirements of EN55022 (FCC Part 15) and CISPR 22 (EN55022) for emissions and relevant sections of EN61000 (IEC 61000) for immunity.

The unit is enclosed inside a metal box, tested at PSE1000DCDC-12V DC/DC module 1000W output using resistive load.

Conducted Emissions

The applicable standard for conducted emissions is EN55022 (FCC Part 15). Conducted noise can appear as both differential mode and common mode noise currents. Differential mode noise is measured between the two input lines, with the major components occurring at the supply fundamental switching frequency and its harmonics. Common mode noise, a contributor to both radiated emissions and input conducted emissions, is measured between the input lines and system ground and can be broadband in nature.

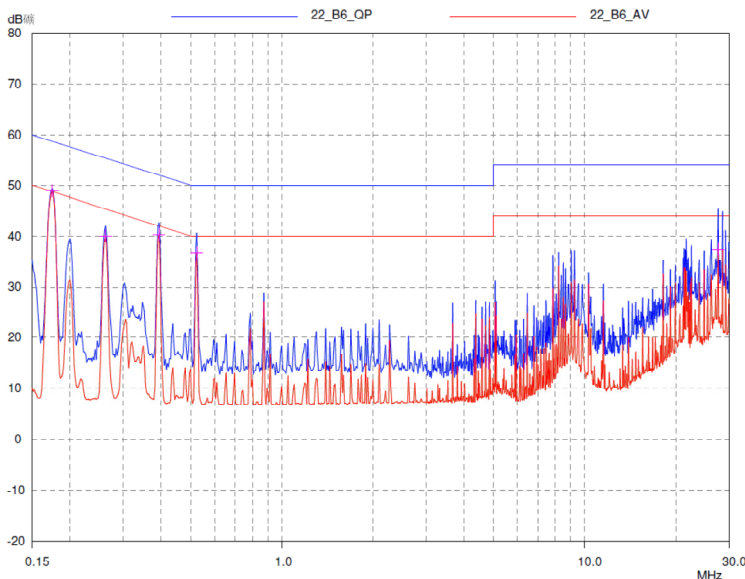

The PSE1000PFC and PSE1000DCDC-12V power supplies with external EMI filters before PSE1000PFC to ensure the converters' conducted EMI levels comply with EN55022 (FCC Part 15) Class B and EN55022 (CISPR 22) Class B limits. The EMI measurements are performed with resistive loads at maximum rated loading.

Sample of EN55022 Conducted EMI Measurement at 230Vac input

Note - Blue Line refers to Emerson Quasi Peak margin, which is 6dB below the CISPR international limit. Red Line refers to the Emerson Average margin, which is 6dB below the CISPR international limit.

Conducted Emissions

Table 8. Conducted EMI emission specifications of the PSE1000PFC and PSE1000DCDC-12V series

Parameter	Model	Symbol	Min	Typ	Max	Unit
FCC Part 15, class B	PSE1000PFC	Margin	-	-	6	dB
VCCI Class II	PSE1000PFC	Margin	-	-	6	dB
CISPR 22 (EN55022) class B for conducted and class B for radiated (stand alone)	PSE1000PFC	Margin	-	-	6	dB
CISPR 22, EN55022 class A (For DC-DC assemblies)	PSE1000PFC	Margin	-	-	6	dB

Radiated Emissions

Unlike conducted EMI, radiated EMI performance in a system environment may differ drastically from that in a stand-alone power supply. The shielding effect provided by the system enclosure may bring the EMI level from Class A to Class B. It is thus recommended that radiated EMI be evaluated in a system environment. The applicable standard is EN55022 Class A (FCC Part 15). Testing ac-dc convertors as a stand-alone component to the exact requirements of EN55022 can be difficult, because the standard calls for 1m leads to be attached to the input and outputs and aligned such as to maximize the disturbance. In such a set-up, it is possible to form a perfect dipole antenna that very few ac-dc convertors could pass. However, the standard also states that 'an attempt should be made to maximize the disturbance consistent with the typical application by varying the configuration of the test sample.

Storage and Shipping Temperature / Humidity

The PSE1000PFC series power supplies can be stored or shipped at temperatures between -40 °C to +85 °C and relative humidity from 10% to 100% non-condensing.

Altitude

The PSE1000PFC series will operate within specifications at altitudes up to 13,000 feet (maximum) above sea level. The power supply shall not be damaged when stored at altitudes of up to 50,000 feet (maximum) above sea level.

Humidity

The PSE1000PFC series will operate within specifications when subjected to a relative humidity from 10% to 100% non-condensing. The PSE1000PFC series can be stored in a relative humidity from 10% to 100% non-condensing.

Vibration

The PSE1000PFC power supply will pass the following vibration specifications: (Per MIL-STD-810F 514.5, Cat, IEC68-2-6)

Operating Random Vibration

Acceleration	4.0	gRMS						
Frequency Range	8-500	Hz						
Sweep Rate	1	Oct/Min						
Duration	1	Mins						
No of Sweep	3	Sweep						
Direction	3 mutually perpendicular axis							
PSD Profile	<table border="0"> <tr> <td><u>FREQ</u></td> <td><u>Level</u></td> </tr> <tr> <td>8-200 Hz</td> <td>2.0g</td> </tr> <tr> <td>200-500 Hz</td> <td>4.0g</td> </tr> </table>	<u>FREQ</u>	<u>Level</u>	8-200 Hz	2.0g	200-500 Hz	4.0g	
<u>FREQ</u>	<u>Level</u>							
8-200 Hz	2.0g							
200-500 Hz	4.0g							

Shock

The PSE1000PFC power supply will pass the following shock specifications: MIL-STD-810F 516.5, IEC 68-2-27, test Ea. The unit shall be subjected to three positive and three negative pulses in each axis while operational in the system. Each pulse shall be 30g, half sine and 11 msec duration.

Operating Half-Sine Shock

Acceleration	30	G
Duration	11	msec
Pulse	Half-Sine	
No. of Shock	3 shock on each of 6 faces	

Power and Control Signal Descriptions

AC Input Connector

These connectors supply the AC Mains to the PSE1000PFC power supply. A power resistor of 10 to 90 Ohm of 10 watt or above (depending on the output capacitance) should be connected from the pin INRUSH to the -Vo output pin. An internal MOSFET bypasses this external thermistor/ resistor during normal operation

- INPUT L1 - Line
- INPUT L2 - Neutral
- INRUSH - Limit Inrush Current

DC Output Connector

The two connectors provide the main output for the PSE1000PFC. The OUTPUT “+” and the OUTPUT “-” pins are the positive and negative rails, respectively of the V_O output of the PSE1000PFC power supply. The Output (V_O) connectors are electrically isolated from the power supply chassis. Bulk capacitors of minimum 2 x 330uF, 450V (or 1 x 680uF, 450V) is recommended be put across the DC output.

- OUTPUT+ - DC Output+
- OUTPUT- - DC Output Return

Output Connector - Control Signals

The PSE1000PFC contains 8 pins control signal headers providing analogy control interface, Current Share and REMOTE interface.

S GND (Signal Ground)

The S GND pin is connected to the internal common ground of the module. It is also internally connected to the –OUTPUT terminal. When connecting S GND to external circuitry care must be taken to ensure that the current flowing through this pin is kept below 25mA.

RELAY

The RELAY is reservation pin to control the relay out of the unit to short the inrush resistor. But in this version unit, there are MOSFETs inside the model to short the inrush resistor.

C_MON

The C_MON is for current monitoring of PSE1000PFC.

VIN(Vac)	Frequency(Hz)	Iout(A)	C_MON Specs(V)
115	50	1.128	0.4+/-0.04
115	50	2.82	1.00+/-0.10
230	50	1.128	0.4+/-0.04
230	50	2.82	1.00+/-0.10

C_SHARE

The main output shall have active load sharing. The output will be within 10% at full load. All current sharing functions are implemented internal to the power supply by making use of the C_SHARE signal. The system connects the C_SHARE lines between the power supplies. The supplies must be able to load share with up to 10 power supplies in parallel.

TXD

TXD is the serial output pin of the UART(Universal Asynchronous Receiver and Transmitter) digital communication. It's used for transmitting data to an external device.

RXD

RXD is the serial input pin of the UART(Universal Asynchronous Receiver and Transmitter) digital communication. It's used for receiving data for the internal MCU. The UART(Universal Asynchronous Receiver and Transmitter) digital communication of PSE1000PFC and computer can just be used to read particular data or variable such as Input Voltage, Input Current, Input Power, Output Voltage, Output Current, Primary Temperature and so on. It can't be used to adjust the fixed parameter such as OCP,OVP and OTP point etc.

Below setup shows the software communication of PSE1000PFC and computer.

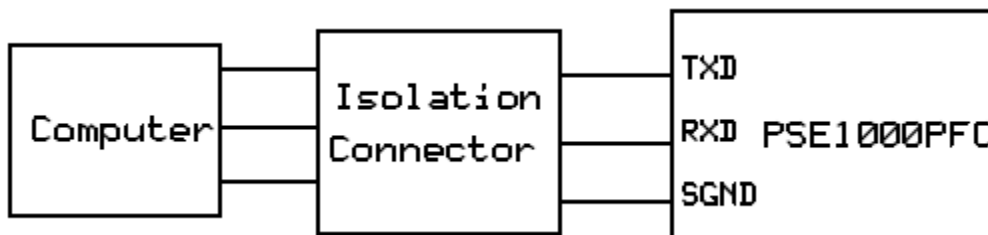

Note: Don't connect PSE1000PFC to computer directly. Please isolate the PSE1000PFC and computer with communication ports with optocouplers.

Below the Transaction Index Pointer indicates what particular data or variable will be transacted in the communication

Transaction Index Pointer	Description
0x03	Input Voltage Register
0x04	Input Current Register
0x05	Primary Temperature Register
0x06	Bulk Voltage Register
0x07	Input Power Register
0x08	Primary Temperature 2 Register
0x09	Output Current Register

LD_EN

PSE1000PFC is designed to power on at no load. After the PFC power up sequence, the power to the load can be enabled. This can be performed manually or the PFC can automatically enable the load using the LD_EN signal. The LD_EN is PFC Module Enable Output. This TTL compatible signal will go high when the soft start has been completed and output voltage is within regulation. Initially the load is disabled and the LD_EN is less than 0.4V (LOW). When the PFC power up sequence has completed, the LD_EN voltage goes HIGH to automatically enable the load.

LD_EN low level: Less than 0.4V while sinking 5mA.

LD_EN high level: Less than 100uA sourcing at 4-5V.

REMOTE

The REMOTE is for remote control of the PFC module. It is negative logic and TTL compatible signal, pull the pin to low to enable PFC. When pull Remote to low, the LD_EN will become high in one second. When set the Remote to high, the LD_EN will become low in 25ms.

Vin (Vac)	Iout (A)	Remote On Spec (ms)	Remote Off Spec (ms)	
			Min	Max
90	0	<1000	15	25
230	0	<1000	15	25
264	0	<1000	15	25

Note - Remote high level: 4-5V, Remote low level

Application Notes

Block Diagram

Below is the block diagram of the PSE1000PFC series power supply.

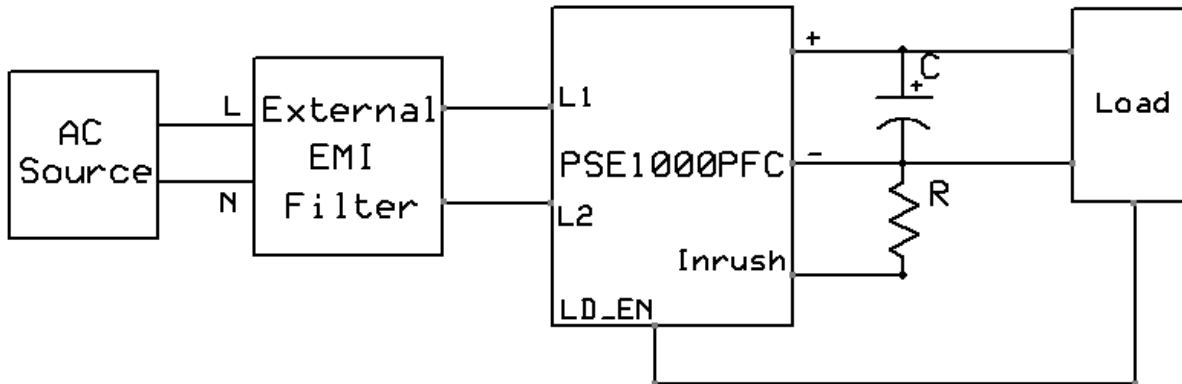

Recommended External EMI Filter Schematic

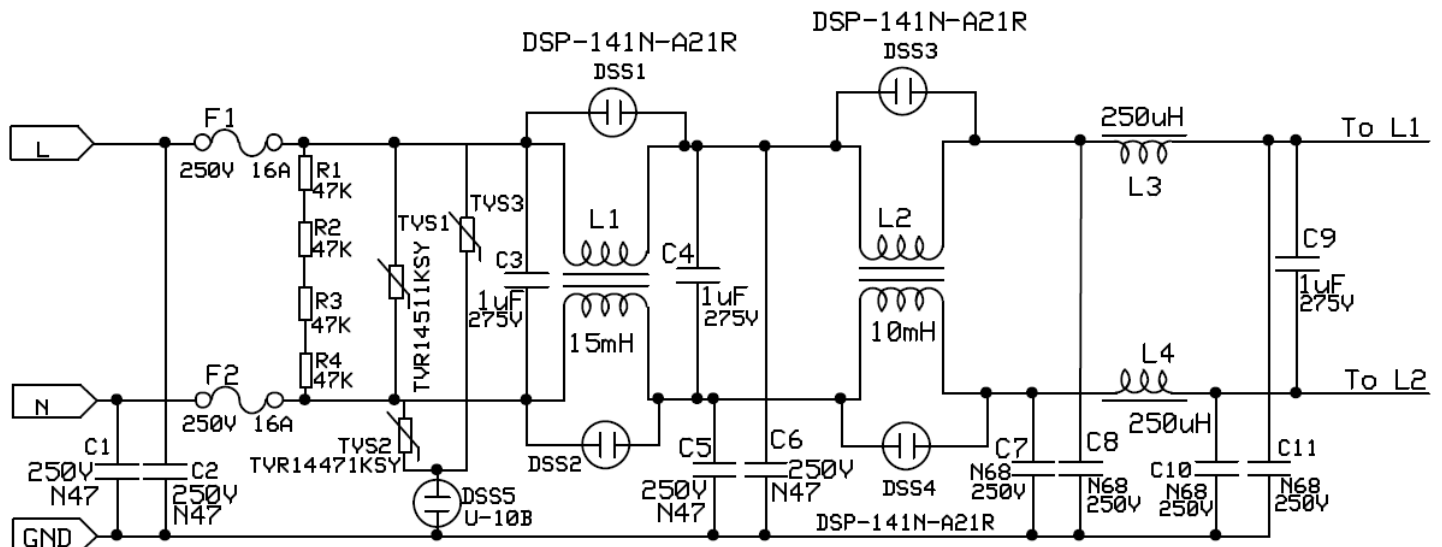

Application Notes

Recommended External EMI Filter BOM

Assembly	Part Number	Manufacturer	Description	Quantity
F1, F2	0216016.XEP	Littelfuse	250V/16A Axial Lead Fuse	2
C1,C2, C5,C6	CD95-B2GA471KYAS	TDK	CAP-C N47 K 250VAC Y KX Ceramic Insulated Capacitor	4
C3,C4,C9	PHE840EY7100MD16R06L2	RIFA	CAP-MPP 1uF K 275VAC GSL Box-type Metalized Polypropylene Film Interference Suppression Capacitor (Class X2)	3
C7,C8,C10,C11	CD75-E2GA681MYAS	TDK	CAP-C N68 M 250VAC Y CD Ceramic Insulated Capacitor	4
R1,R2,R3,R4	RK73H2BTDD4752F	KOA SPEER	RES-TFC 47K F W25 RK73H Thick Film Resistors - SMD	4
TVS1	TVR14511KSY	TKS	VDR =510V K 0W6 Transient Voltage Suppressor	1
TVS2,TVS3	TVR14471KSY	TKS	VDR =470V K 0W6 Transient Voltage Suppressor	2
DSS1,DSS2, DSS3,DSS4	DSP-141N-A21R	MITSUBISHI	Gas arrester	4
DSS5	U-10B	SANKOSHA	Gas arrester	1
L1	CMT03615 series T14033	FALCO electronics	15mH Common mode choke	1
L2	CMT03615 series T14070	FALCO electronics	10mH Common mode choke	1
L3,L4	SF-T15-40L-01-PF	TDK	250uH Differential mode choke	2

Output Ripple and Noise Measurement

The setup outlined in the diagram below has been used for output voltage ripple and noise measurements on the PSE1000PFC Series. When measuring output ripple and noise, a scope jack in parallel with a 0.1uF ceramic chip capacitor, and a 10uF aluminum electrolytic capacitor should be used. Oscilloscope should be set to 20 MHz bandwidth for this measurement.

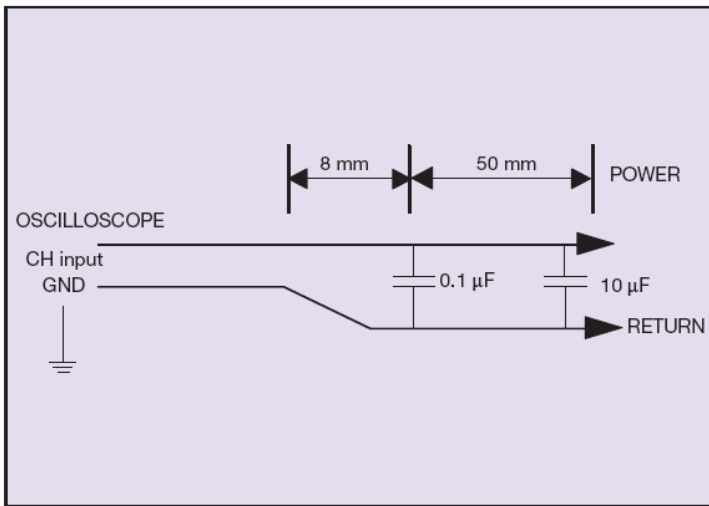

WORLDWIDE OFFICES

Americas

2900 S.Diablo Way
Tempe, AZ 85282
USA
+1 888 412 7832

Europe (UK)

Waterfront Business Park
Merry Hill, Dudley
West Midlands, DY5 1LX
United Kingdom
+44 (0) 1384 842 211

Asia (HK)

14/F, Lu Plaza
2 Wing Yip Street
Kwun Tong, Kowloon
Hong Kong
+852 2176 3333

ARTESYN[™]
EMBEDDED TECHNOLOGIES

www.artesyn.com

While every precaution has been taken to ensure accuracy and completeness in this literature, Artesyn Embedded Technologies assumes no responsibility, and disclaims all liability for damages resulting from use of this information or for any errors or omissions. Artesyn Embedded Technologies, Artesyn and the Artesyn Embedded Technologies logo are trademarks and service marks of Artesyn Technologies, Inc. All other names and logos referred to are trade names, trademarks, or registered trademarks of their respective owners.
© 2014 All rights reserved.

For more information: www.artesyn.com/power
For support: productsupport.ep@artesyn.com