

## DS1100SLPE 1100 Watts Distributed Power System

### Data Sheet

**Front-end Bulk Power**  
**Total Output Power:**  
 1100 W continuous  
**Wide Input Voltage:**  
 90 to 264 Vac

### SPECIAL FEATURES

- 1100 W output power
- High power and short form factor
- 1U power supply
- High density design: 26 W/in<sup>3</sup>
- Active Power Factor Correction
- EN61000-3-2 harmonic compliance
- Inrush current control
- 80plus Platinum Efficiency
- N+1 or N+N Redundant
- Hot-pluggable
- Active current sharing
- Full digital control
- PMBus compliant
- Accurate input power reporting
- Compatible with Artesyn's Universal PMBus GUI
- Reverse airflow option
- Two-year warranty

### COMPLIANCE

- EMI Conducted/Radiated Class A Limits + 6 dB margin
- EN61000-4 Electromagnetic compatibility
- RoHS 6/6

### SAFETY

- UL/cUL 60950 (UL Recognized)
- DEMKO+ CB Report EN60950
- CE Mark
- China CCC
- BSMI



### Electrical Specifications

Input						
Input range	90 - 264 Vac					
Frequency	47 Hz to 63 Hz					
Efficiency	94.0% peak					
Max input current	14.5 Arms					
Inrush current	55 Apk					
Conducted EMI	Class A +6 dB margin					
Radiated EMI	Class A +6 dB margin					
Power factor	> 0.9 beginning at 20% load					
ITHD	10%					
Leakage current	1.75 mA					
Hold-up time	16 ms at full load					
Output						
	Main DC Output			Standby DC Output		
	MIN	NOM	MAX	MIN	NOM	MAX
Nominal setting	-1%	12	+1%	-1%	3.3	1%
Total output regulation range	11.64 V	12	12.36 V	3.14 V	3.3	3.46 V
Dynamic load regulation range	11.64 V		12.36 V	3.14 V		3.46 V
Output ripple			180 mVp-p			45 mVp-p
Output current	0.5 A <sup>1</sup>		90.0 A	0.1 A		3.0 A
Current sharing	Within ±5.625A of each other from 25% to 100% load			N/A		
Capacitive loading	500 µF		11,000 µF	20 µF		1000 µF
Start-up from AC to output			2200 ms			1700 ms
Output rise time	5 ms		50 ms	2 ms		60 ms

Note: Outputs shall be isolated from the chassis ground by at least 50 V.

<sup>1</sup>Minimum starting current for transient load response testing only. Unit is designed to operate and be within output regulation at zero load.

## Electrical Specifications

### Protections

Main Output	MIN	NOM	MAX
Overcurrent protection <sup>2</sup>	107%		130%
Overvoltage protection <sup>1</sup>	13.5 V		15.0 V
Overtemperature protection	Yes, autorecovery		
Fan fault protection		Yes	
Standby Output			
Overcurrent protection <sup>3</sup> :	110%		150%
Overvoltage protection <sup>1</sup>	3.6 V		3.9 V

<sup>1</sup> Latch mode

<sup>2</sup> No shutdown if the overcurrent is within the range and does not last for more than 200 ms, otherwise latch will occur

<sup>3</sup> Autorecovery

## Control and Status Signals

### Input Signals

#### PSON\_L

Active LOW signal which enables/disables the main output. Pulling this signal LOW will turn-on the main output. Recommended pull-up resistor to VSB is 5.1 kohms. A 100 pF decoupling capacitor is also recommended.

		MIN	MAX
$V_{IL}$	Input logic level LOW		0.8 V
$V_{IH}$	Input logic level HIGH	2.0 V	3.6 V
$I_{SOURCE}$	Current that may be sourced by this pin		2 mA
$I_{SINK}$	Current that may be sunk by this pin at low state		0.5 mA

#### PSKILL\_H

First break/last mate active LOW signal which enables/disables the main output. This signal will have to be pulled to ground at the system side with a 220 ohm resistor. A 100 pF decoupling capacitor is also recommended.

		MIN	MAX
$V_{IL}$	Input logic level LOW		0.8 V
$V_{IH}$	Input logic level HIGH	2.0 V	3.6 V
$I_{SOURCE}$	Current that may be sourced by this pin		2 mA
$I_{SINK}$	Current that may be sunk by this pin at low state		0.5 mA

#### VSENSE+, VSENSE-

VSENSE+ and VSENSE- lines are the remote sense lines for regulation. Each line will compensate for a maximum of 100 mV

## Ordering Information

Model Number	Nominal Main Output	Standby Output	Airflow Direction
DS1100SLPE-3	12 V	3.3 V @ 3 A	Std (forward)
DS1100SLPE-3-001	12 V	3.3 V @ 3 A	Reverse <sup>1</sup>

<sup>1</sup> Derating may apply.

## I2C Addressing

A1 Pin	A0 Pin	PMBus (w/r)
0	0	B0/B1
0	1	B2/B3
1	0	B4/B5
1	1	B6/B7

## Control and Status Signals

### Output Signals

#### ACOK

Signal used to indicate the presence of AC input to the power supply. A logic level HIGH will indicate that the AC input to the power supply is within the operating range while a logic level LOW will indicate that AC has been lost.

This is an open collector/drain output. This pin is pulled high by a 10 kohm resistor connected to 3.3 V inside the power supply. It is recommended that this pin be connected to a 100 pF decoupling capacitor and pulled down by a 100 kohm resistor.

		MIN	MAX
$V_{IL}$	Input logic level LOW		0.6 V
$V_{IH}$	Input logic level HIGH	2.0 V	3.6 V
$I_{SOURCE}$	Current that may be sourced by this pin		3.3 mA
$I_{SINK}$	Current that may be sunk by this pin at low state		0.7 mA

#### PWR\_GOOD / PWOK

Signal used to indicate that main output voltage is within regulation range. The PWR\_GOOD signal will be driven HIGH when the output voltage is valid and will be driven LOW when the output falls below the under-voltage threshold.

This signal also gives an advance warning when there is an impending power loss due to loss of AC input or system shutdown request. More details in the Timing Section.

This is an open collector/drain output. This pin is pulled high by a 10 kohm resistor connected to 3.3 V inside the power supply. It is recommended that this pin be connected to a 100 pF decoupling capacitor and pulled down by a 100 kohm resistor.

		MIN	MAX
$V_{IL}$	Input logic level LOW		0.8 V
$V_{IH}$	Input logic level HIGH	2.0 V	3.6 V
$I_{SOURCE}$	Current that may be sourced by this pin		3.3 mA
$I_{SINK}$	Current that may be sunk by this pin at low state		0.7 mA

### Output Signals

#### PS\_PRESENT

Signal used to indicate to the system that a power supply is inserted in the power bay. This pin is shorted to the standby return in the power supply. Recommended pull-up resistor to VSB is 5.1 kohms. A 100 pF decoupling capacitor is also recommended.

#### PS\_INTERRUPT

Active low signal used by the power supply to indicate to the system that a change in power supply status has occurred. This event can be triggered by faults such as OVP, OCP, OTP, and fan fault. This signal can be cleared by a CLEAR\_FAULT command. Recommended pull-up resistor to VSB is 5.1 kohms. A 100 pF decoupling capacitor is also recommended.

		MIN	MAX
$V_{IL}$	Input logic level LOW		0.8 V
$V_{IH}$	Input logic level HIGH	2.0 V	3.6 V
$I_{SOURCE}$	Current that may be sourced by this pin		4 mA
$I_{SINK}$	Current that may be sunk by this pin at low state		4 mA

## Control and Status Signals

### BUS Signals

#### ISHARE

Bus signal used by the power supply for active current sharing. All power supplies configured in the system for n+n sharing will refer to this bus voltage in order to load share.

Voltage Range	The range of this signal for active sharing will be up to 8.0 V, which corresponds to the maximum output current.		
		<b>MIN</b>	<b>MAX</b>
$I_{SHARE}$ Voltage	Input logic level LOW	7.75	8.25
	Voltage at 50% load, stand-alone unit	3.85	4.15
	Voltage at 0% load, stand-alone unit	0	1.0
$I_{SOURCE}$	Current that may be sourced by this pin		160 mA

#### SCL, SDA

Clock and data signals defined as per I2C requirements. It is recommended that these pins be pulled-up to a 2.2 kohm resistor to 3.3 V and a 100 pF decoupling capacitor at the system side.

VL	Input logic level LOW		0.8 V
VH	Input logic level HIGH	2.0 V	3.6 V

**Note:** All signal noise levels are below 400 mVpk-pk from 0 - 100 MHz.

## Electrical Specifications

### LED Indicators

A single bi-color LED is used to indicate the power supply status.

	Status LED	Fail LED
Color	Green	Amber/Green
No input to PSU	Off	Off
Input present, STBY ON, main output OFF	On	Blinking Amber, at least 1 Hz
Main output ON	On	green
Power supply warning (hi-temp)	On	Blinking Amber/Green, at 2:1 ratio, at least 1 Hz
Power supply warning (slow fan)	Off	Blinking Amber/Green, at 1:1 ratio, at least 1Hz
Power supply failure (OVP, OTP, FAN FAULT)	On	Amber

### Firmware Reporting And Monitoring

	Accuracy Range		
Output loading	<10%	10% to 20%	20% to 100%
Input voltage	±5%		
Input current	±1 A fixed error	±10%	±5%
Input power	30 W fixed error up to 120 W	±15%	±10%
Output voltage	±5%		±2%
Output current	0.8 A fixed error	±15%	±5%
Temperature	±5 °C		
Fan speed	Actual ±250 RPM		

PMBus	YES
Remote ON/OFF	YES

## Electrical Specifications

Timing Specifications				
	Description	Min	Max	Unit
$T_{sb\_On}$	Delay from AC being applied to standby output being within regulation		2500	ms
$T_{sb\_ACOK}$	Delay from standby output to ACOK assertion		1500	ms
$T_{sb\_Vout}$	Delay from standby output to main output voltage being within regulation		1000	ms
$T_{AC\_On\_Delay}$	Delay from AC being applied to main output being within regulation		3000	ms
$T_{PWR\_GOOD\_On}$	Delay from output voltages within regulation limits to PWOK asserted	100	1000	ms
$T_{ACOK\_Delay}$	Delay from loss of AC to assertion of ACOK		20	ms
$T_{PWR\_GOOD\_Hold-up}$	Delay from loss of AC to deassertion of PWOK	5		ms
$T_{Vout\_Hold-up}$	Delay from loss of AC to main output being within regulation	16		ms
$T_{sb\_Hold-up}$	Delay from loss of AC to standby output being within regulation	25		ms
$T_{PWR\_GOOD\_Off}$	Delay from deassertion of PWOK to output falling out of regulation	1	700	ms
$T_{PSON\_On\_Delay}$	Delay from PSON assertion to output being within regulation		400	ms

## Timing Diagram

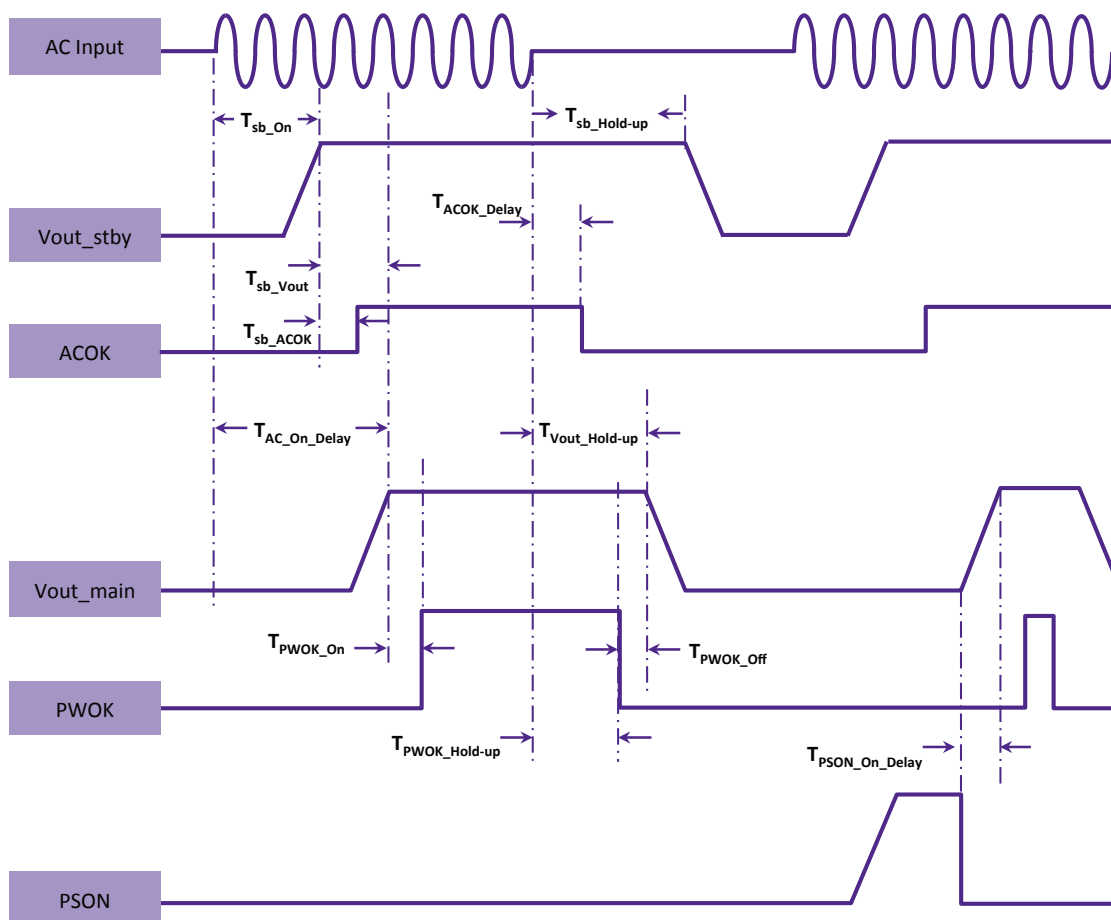



## Mechanical Outline

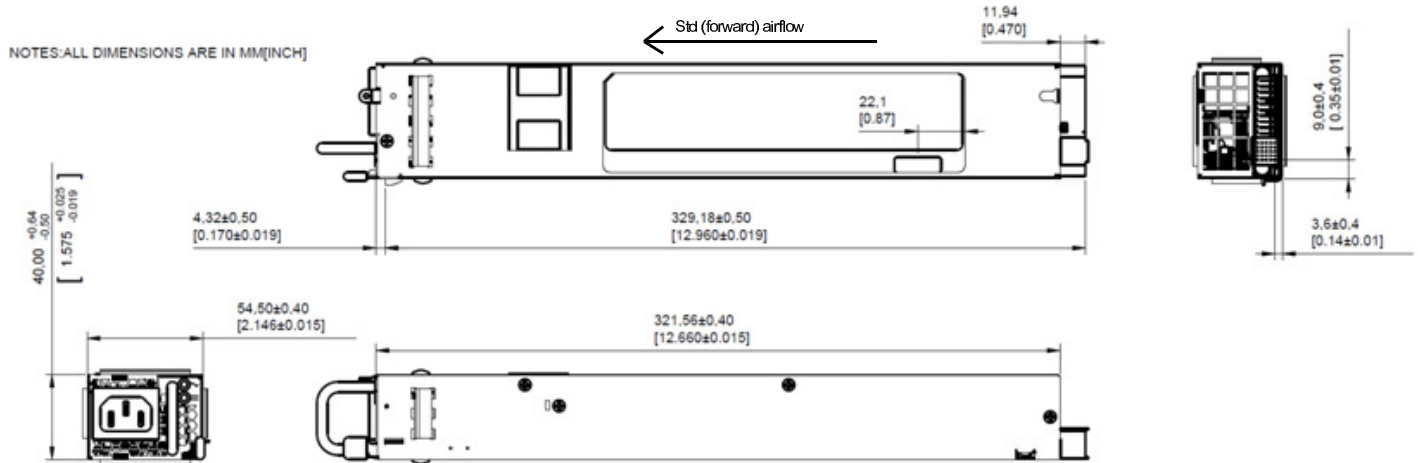

## Output Connector

Output Connector Part Number	TEI 2-1926736-2
Mating Connector Part Number	TEI 2-1926739-5, 1892787-6 or equivalent

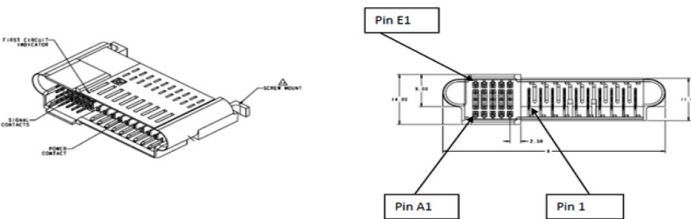

## Output Connector Pin Configuration

Pin	Signal	Description
A1	3.3 VSB	Standby Output
B1	3.3 VSB	Standby Output
C1	3.3 VSB	Standby Output
D1	3.3 VSB	Standby Output
E1	3.3 VSB	Standby Output
A2	SGND	Signal Ground
B2	SGND	Signal Ground
C2	Reserved	
D2	Reserved	
E2	Reserved	
A3	A2/A_Select	Optional address line
B3	A0	I <sup>2</sup> C Address
C3	SDA	I <sup>2</sup> C Data
D3	-Remote_Sense	Wire drop compensation
E3	+Remote_Sense	Wire drop compensation
A4	SCL	I <sup>2</sup> C Clock
B4	PSON_L	Enable/Inhibit
C4	PS_INTERRUPT_L	Alert for failure
D4	A1	I <sup>2</sup> C Address
E4	ACOK	Input indicator
A5	PSKILL_L	First break/lastmate pin
B5	ISHARE	Current share bus
C5	PWOK	Output indicator
D5	Reserved	
E5	PS_PRESENT_L	Power supply present
P1-P5	+12 V Return	Main output return contact
P6-P10	12 V	Main output power contact

## Environmental Specifications

<b>Operating temperature</b>	DS1100SLPE-3 DS1100SLPE-3-001	Full power at -5 to 55 °C, can operate up to 65 °C at 660 W derated power Full power at -5 to 45 °C, can operate up to 55 °C at 660 W derated power
<b>Operating relative humidity</b>	5% to 90% non-condensing	
<b>Operating altitude</b>	up to 10,000 feet	
<b>Non-operating temperature</b>	-40 to +70 °C	
<b>Non-operating relative humidity</b>	10% to 95% non-condensing	
<b>Non-operating altitude</b>	up to 50,000 feet	
<b>Storage temperature</b>	-40 to +85 °C	
<b>Storage relative humidity</b>	5% to 95% non-condensing	
<b>Vibration and shock</b>	Standard operating/non-operating random shock and vibration	
<b>RoHS compliance</b>	Yes	
<b>MTBF</b>	>500,000 hours using Telcordia Issue 2, Method 1 Case 1 at 40 °C ambient at full load.	
<b>Operating life</b>	Minimum of 7 years at typical operating conditions	
<b>Reliability</b>	All electronic component derating analysis and capacitor life calculation is done at 40 °C ambient, 80% of maximum rated load, nominal input line voltage.	

## WORLDWIDE OFFICES

### Americas

2900 S.Diablo Way  
Tempe, AZ 85282  
USA  
+1 888 412 7832

### Europe (UK)

Waterfront Business Park  
Merry Hill, Dudley  
West Midlands, DY5 1LX  
United Kingdom  
+44 (0) 1384 842 211

### Asia (HK)

14/F, Lu Plaza  
2 Wing Yip Street  
Kwun Tong, Kowloon  
Hong Kong  
+852 2176 3333

**ARTESYN**<sup>™</sup>  
EMBEDDED TECHNOLOGIES

[www.artesyn.com](http://www.artesyn.com)

Artesyn Embedded Technologies, Artesyn and the Artesyn Embedded Technologies logo are trademarks and service marks of Artesyn Embedded Technologies, Inc. All other names and logos referred to are trade names, trademarks, or registered trademarks of their respective owners. © 2016 Artesyn Embedded Technologies, Inc. All rights reserved. For full legal terms and conditions, please visit [www.artesyn.com/legal](http://www.artesyn.com/legal).

For more information: [www.artesyn.com/power](http://www.artesyn.com/power)  
For support: [productsupport.ep@artesyn.com](mailto:productsupport.ep@artesyn.com)