

THIS DRAWING IS UNPUBLISHED. RELEASED FOR PUBLICATION 20
 © COPYRIGHT 20 BY - ALL RIGHTS RESERVED.

REVISIONS				
P	LTR	DESCRIPTION	DATE	APVD
B		REV; ECO-13-019670	16DEC2013	GG RA

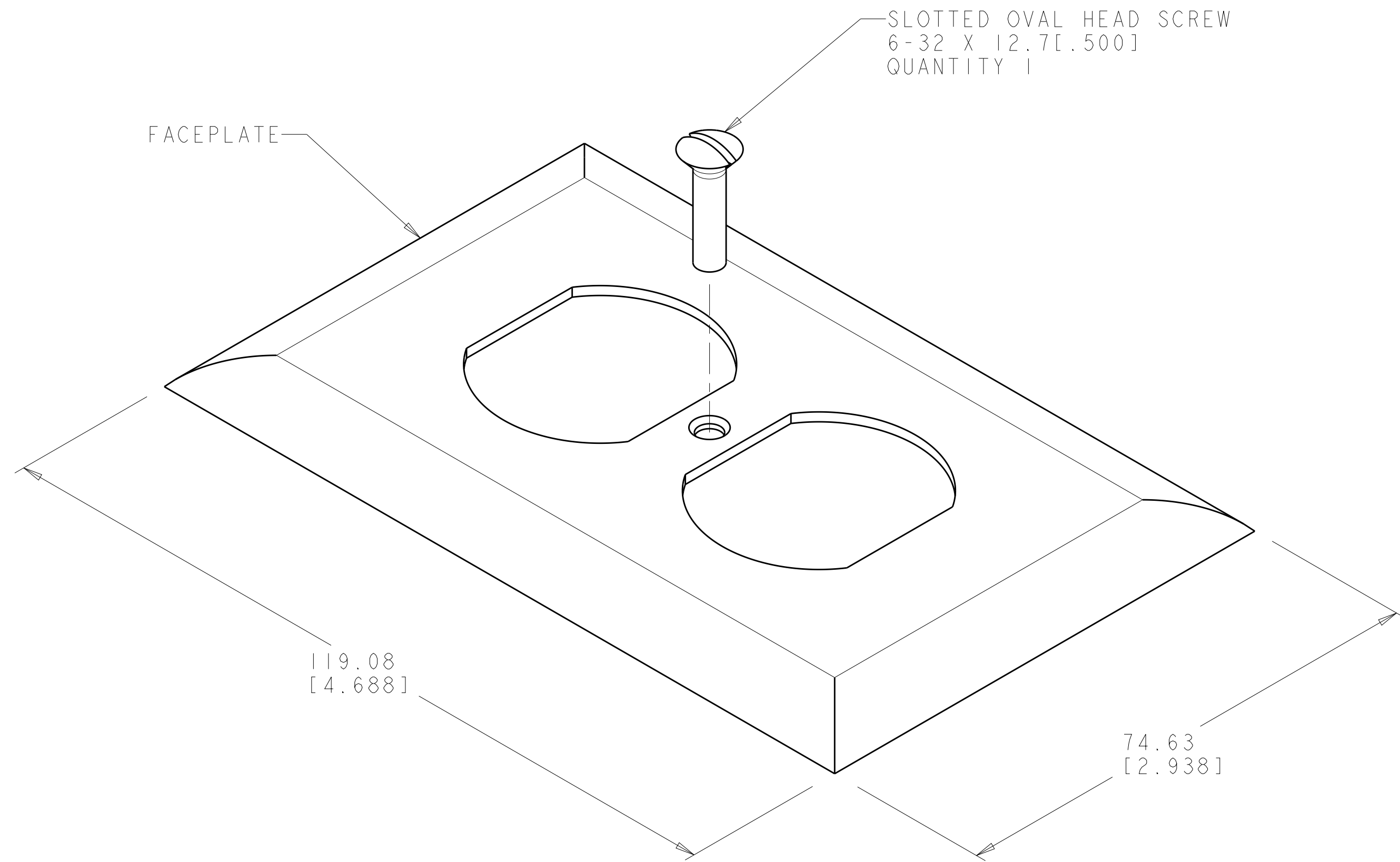

SLOTTED OVAL HEAD SCREW
 6-32 X 12.7 [.500]
 QUANTITY 1

FACEPLATE

- 1. MATERIAL: FACEPLATE - NYLON MOLDING COMPOUND. SEE TABLE FOR COLOR. SCREWS - PAINTED HEAD, ZINC PLATED CARBON STEEL. SEE TABLE FOR COLOR.
- 2. DIMENSIONS ARE FOR REFERENCE ONLY.

ALPINE WHITE	1-1479160-3
ELECTRIC IVORY	1-1479160-1
GRAY	1479160-4
WHITE	1479160-3
BLACK	1479160-2
LIGHT ALMOND	1479160-1
COLOR	PART NUMBER

THIS DRAWING IS A CONTROLLED DOCUMENT.		DWN G. GARRETT 16-Dec-13	TE Connectivity	
DIMENSIONS: MM [INCHES]		CHK G. BOWMAN 16-Dec-13		
TOLERANCES UNLESS OTHERWISE SPECIFIED:		APVD G. BOWMAN 16-Dec-13	NAME - KIT, FACEPLATE, DUPLEX	
0 PLC ±	1 PLC ±	PRODUCT SPEC	SIZE A2	
2 PLC ±	3 PLC ±	APPLICATION SPEC	CAGE CODE	DRAWING NO
4 PLC ±	ANGLES ±	WEIGHT	-	G-1479160
FINISH		Customer Drawing	SCALE 2:1	SHEET 1 OF 1 REV B