

0.4 mm Pitch, Horizontal mating, Board- to-Fine Coaxial Cable Connectors

DF49 Series

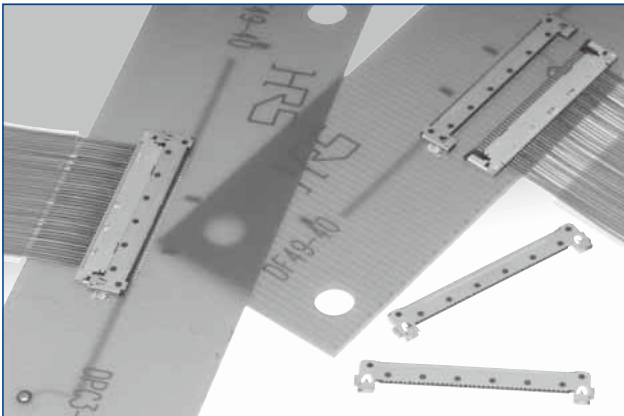

Reliable connection

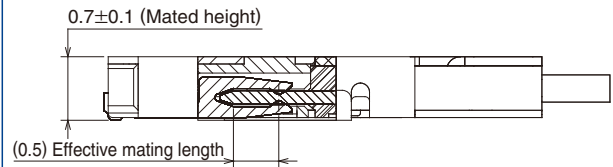

Figure.①

■Features

1.Ultra low-profile structure

A low-profile and space-saving item, with a stacking height of 0.7mm (0.8mm MAX).

2.Reliable electrical and mechanical connection

Despite its small mated height, unique contact configuration assures highly reliable connection, with effective mating length of 0.5mm.(fig.①)

3.Enhanced shielding and ground connections

Metal shells on the plug and receptacle connect to each other, assuring reliable ground connection and EMC protection.

4.Simplified lock structure with audible click

Audibly clicks into place thanks to the two-point lateral lock structure and optimized contact force.

5.Incorrect insertion prevention mechanism

The bend structure of the shell prevents the reverse insertion of the plug connector and mating failure. (fig.②)

6.Solder wicking prevention

Nickel barriers prevent solder wicking in the critical contact areas.(Receptacle)

7.RoHS, Halogen-free*

*As defined by IEC61249-2-21
Br-900 ppm maximum,Cl-900 ppm maximum, Cl+Br combined-1,500 ppm maximum

■Connectors for conductivity tests

We have a line-up of plug connectors for inspection, usable for electrical testing.

Mis-insertion Prevention

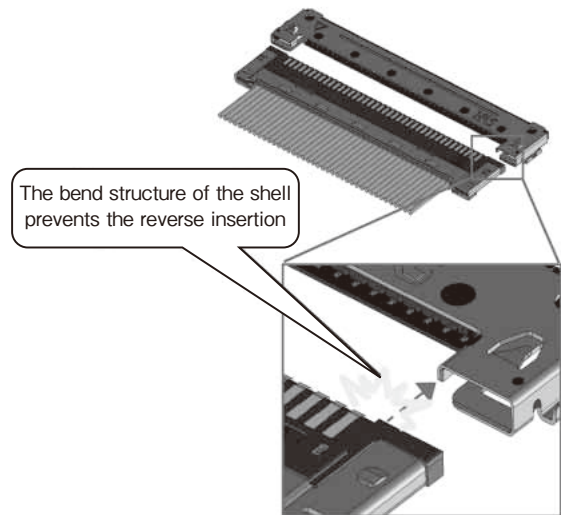

Figure. ②

■ Specifications

Ratings	Current rating	Wire size AWG42 : 0.25A AWG44 : 0.2A (Note 3) AWG46 : 0.15A	Operating temperature range -35°C to 85°C (Note 1) Operating humidity range 20% to 80%
	Voltage rating	AC30V	Storage temperature range -10°C to 60°C (Note 2) Storage humidity range 40% to 70% (Note 2)

Item	Specification	Conditions
1. Insulation resistance	50 MΩ min.	100 V DC
2. Withstanding voltage	No flashover or insulation breakdown	100 Vrms AC / 1 minute
3. Contact resistance	Signal:80mΩ max, Ground 80mΩ max	100 mA,(DC or 1,000Hz)
4. Vibration	No electrical discontinuity of 1 μs or longer	Frequency: 10 to 55 Hz, single amplitude of 0.75mm, 10 cycles in each of the 3 directions
5. Humidity	Contact resistance (change from initial value) 50 mΩ max. Insulation resistance: 25 MΩ min.	96 hours at of 40 ±2°C, and humidity of 90 to 95%
6. Temperature cycle	Contact resistance (change from initial value) 50 mΩ max. Insulation resistance: 25 MΩ min.	-55°C → 5 to 35°C → 85°C → 5 to 35°C Time: 30 min. → 2 to 3 min. → 30 min. → 2 to 3 min. 5 cycles
7. Durability	Contact resistance (change from initial value) 50 mΩ max.	30 cycles
8. Resistance to soldering heat	No deformation of affecting performance	Reflow: At the recommended temperature profile Manual soldering: 350°C for 3 seconds

Note 1: Includes temperature rise caused by current flow.

Note 2: The term "storage" refers to products stored for a long period prior to mounting and use.

The operating temperature and humidity range covers the non-conducting condition of installed connectors in storage, shipment or during transportation after board mounting.

Note 3: With only the connector portion at an elevated temperature level, the rated current value is set.

■ Materials

Product	Part	Material	Finish	Remarks
Receptacle	Insulator	LCP	Color:Black	UL94V-0
	Contacts	Phosphor bronze	Gold plating	——
	Metal fittings	Phosphor bronze	Tin plating	——
Plug	Insulator	LCP	Color:Black	——
	Contacts	Phosphor bronze	Gold plating	UL94V-0
	Metal cover	Phosphor bronze	Tin plating	——
Shell	Metal cover	Phosphor bronze	Tin plating	——

Ordering information

Connector

DF 49 J - * S - 0.4 H ()**

① ② ③ ④ ⑤ ⑥ ⑦ ⑧

DF 49 - * P - SHL

① ② ④ ⑤ ⑨

① Series name:DF	⑥ Contact pitch:0.4mm
② Series No. :49	
③ Connector style Receptacle/Shell J:Receptacle for conductivity tests Blank:Standard	⑦ Termination type H :Rightangle SMT SD:Fine coaxial cable plug
④ Number of positions: 20,30,40	⑧ Packaging (51):Embossed tape packaging
⑤ Connector type S:Receptacle P:Plug	⑨ Installation item(separate) SHL:Metal cover

Combinations

[Standard use]

DF49-*S-0.4H(**) + DF49-*P-ASSY
[DF49-*P-0.4SD(**)
DF49-*P-SHL]

Note: The product specification of the above combination is shown on page 2.

[Receptacle conductivity test]

DF49-*S-0.4H(**) + DF49J-*P-ASSY·(Note)
[DF49J-*P-0.4SD(**)
DF49-*P-SHL]

Note: This harness item is only usable for the receptacle test.

For the product specification of the above combination, please contact our sales department.

[Plug conductivity test]

DF49-*S-0.4H(**) + DF49-*P-ASSY
[DF49-*P-0.4SD(**)
DF49-*P-SHL]

Note: For the product specification, please contact our sales department.

※ : ASSY means a harness item.

Receptacles (SMT)

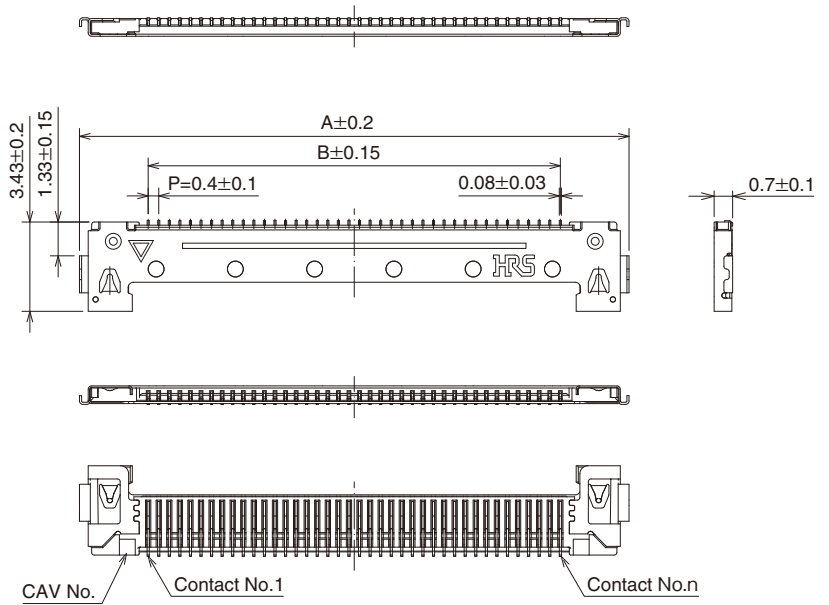
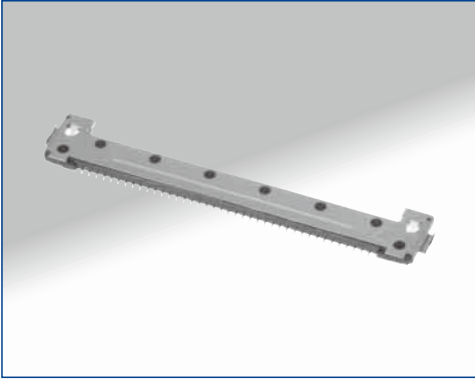

Recommended PCB mounting pattern

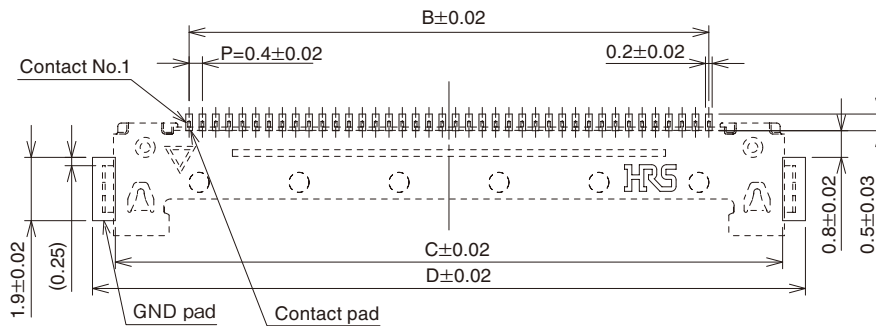

[Specification number] - **, (**)
 (51): Embossed tape packaging
 (7,000 pieces per reel)

Unit : mm

Part Number	CL No.	Number of contacts	A	B	C	D
DF49-20S-0.4H(**)	662-5503-4-**	20	12.8	7.6	12.03	13.4
DF49-40S-0.4H(**)	662-5500-6-**	40	20.8	15.6	20.03	21.4

Note 1: Tape and reel packaging (7,000 pieces/reel).
 Order by number of reels.

Plugs

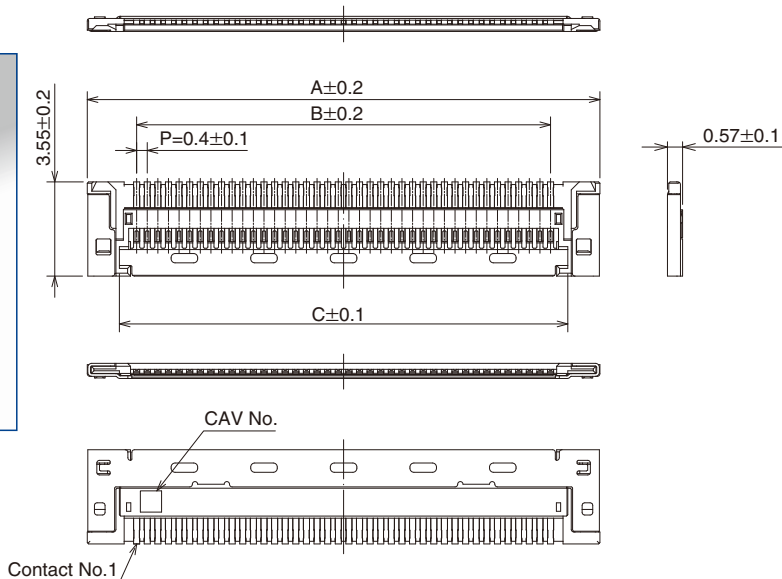

[Specification number] - **, ()**
 (51): Embossed tape packaging
 (7,000 pieces per reel)

Unit : mm

Part Number	CL No.	Number of contacts	A	B	C	D
DF49-20P-0.4SD(**)	662-5504-7-**-	20	11.32	7.6	8.9	8.7
DF49-40P-0.4SD(**)	662-5501-9-**-	40	19.32	15.6	16.9	16.7

Note 1: Tape and reel packaging (7,000 pieces/reel).

Order by number of reels.

Note 2: The metal cover (DF49-*P-SHL) is required for fine coaxial cable termination.

Recommended Fine Coaxial Cable Preparation

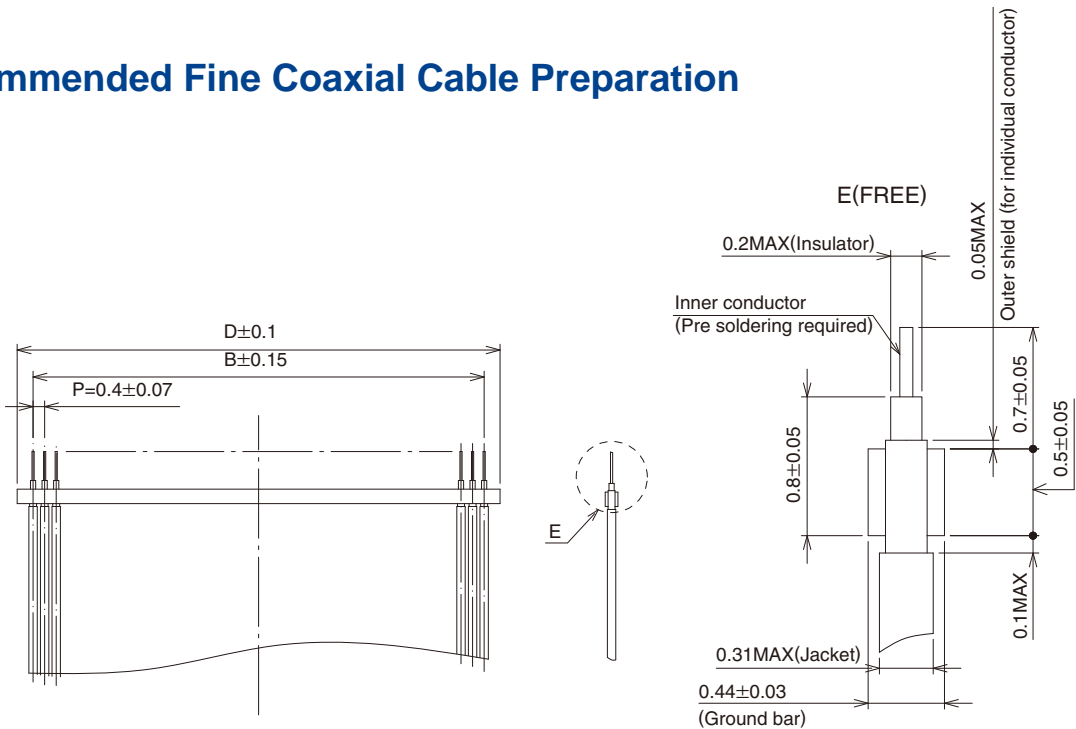

Note 1: Contact Hirose for Termination Procedures.

■ Metal cover

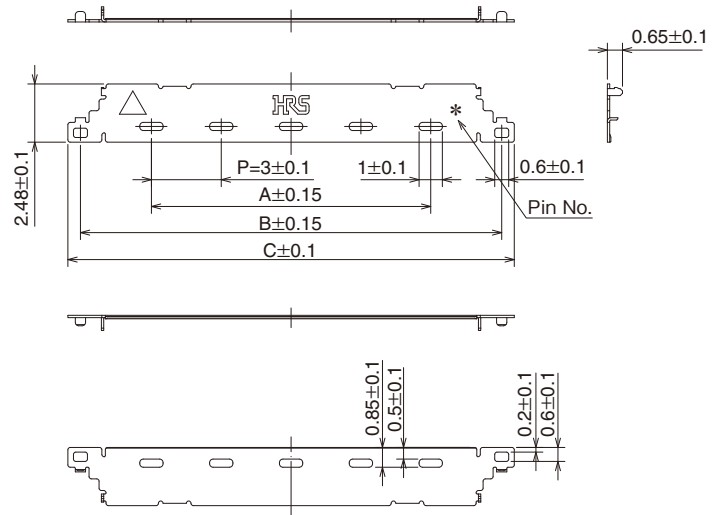
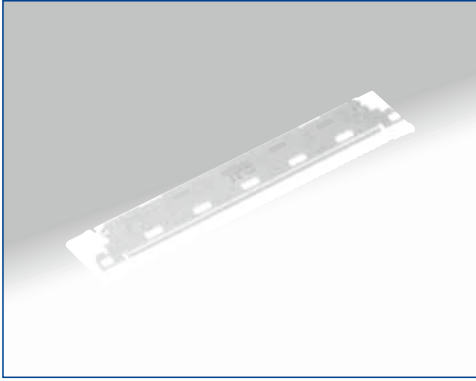

Unit : mm

Part Number	CL No.	Number of contacts	A	B	C
DF49-20P-SHL	662-5505-0	20	4.0	10.1	11.18
DF49-40P-SHL	662-5502-1	40	12.0	18.1	19.18

Note 1 : Reel packaging (10,000 pieces/reel).
Order by number of reels.

■ Packaging Specification

● Embossed Carrier Tape Dimensions

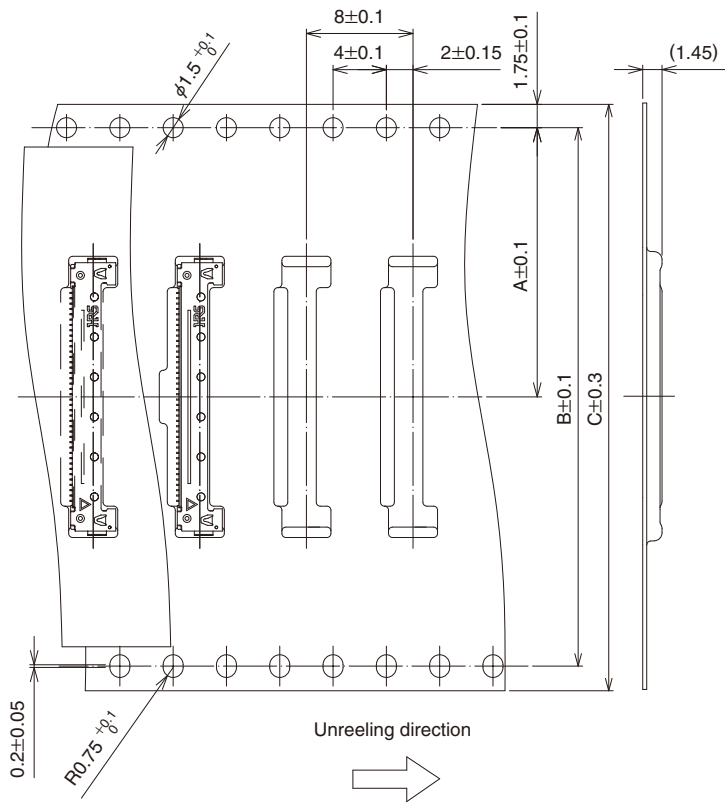

● Reel Dimensions

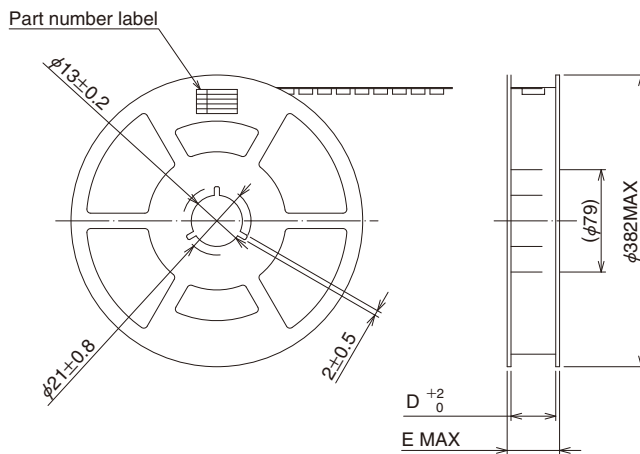

Unit : mm

Part Number	CL No.	Number of contacts	A	B	C	D	E
DF49-20S-0.4H(51)	662-5503-4-51	20	11.5	-	24.0	24.4	30.4
DF49-40S-0.4H(51)	662-5500-6-51	40	20.2	40.4	44.0	44.4	50.4

Note 1 : Embossed tape will have perforated feed holes on single side (20pos.)

■ Packaging Specification

● Plugs

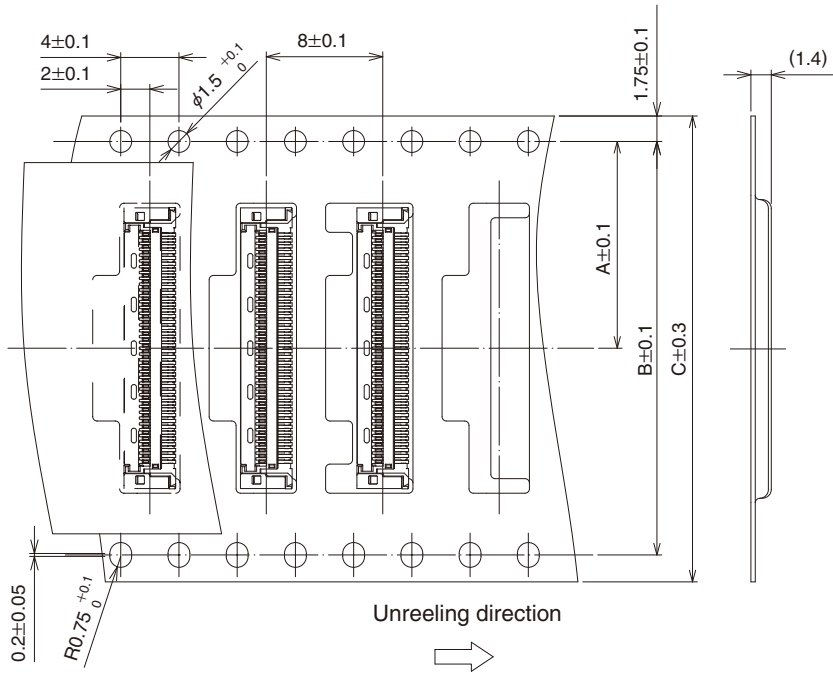

● Reel Dimensions

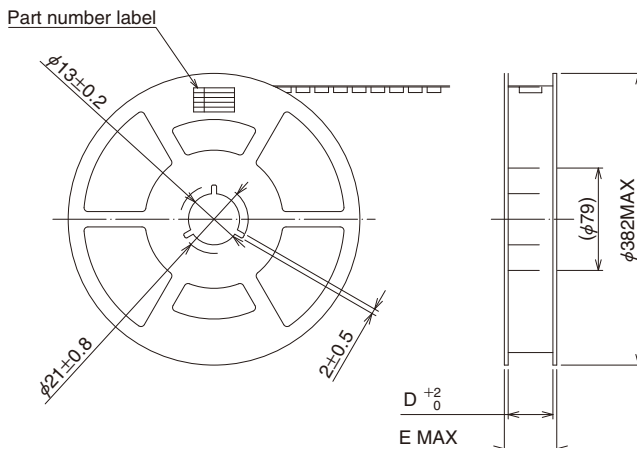

Unit : mm

Part Number	CL No.	Number of contacts	A	B	C	D	E
DF49-20P-0.4SD(51)	662-5504-7-51	20	11.5	-	24.0	24.4	30.4
DF49-40P-0.4SD(51)	662-5501-9-51	40	14.2	28.4	32.0	32.4	38.4

Note 1 : Embossed tape will have perforated feed holes on single side (20pos.)

■ Extraction tool

For details about the extraction tool, please contact your Hirose sales representative.

■ Precautions

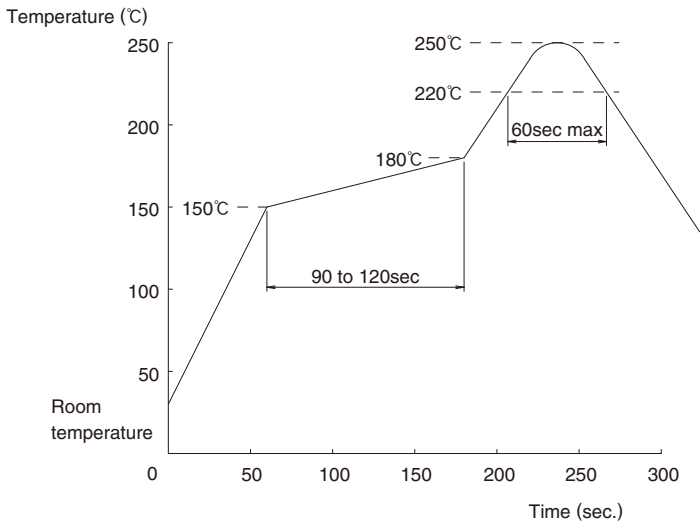
1.Recommended temperature profile	 <p>Solder composition : Paste, 96.5%Sn/3.0%Ag/0.5%Cu</p> <p>Note 1: Up to 2 cycles of Reflow soldering are possible under the same conditions, provided that there is a return to normal temperature between the first and second cycle.</p> <p>Note 2: The temperature profile indicates the board surface temperature at the point of contacts with the connector terminals.</p>
2.Recommended manual soldering	Manual soldering: 350°C for 3 seconds Do NOT use flux compound when manual soldering.
3.Recommended screen thickness and open area ratio (Pattern area ratio)	Standard thickness 0.1mm Open area ratios:Lead terminal 100% :Ground terminal 75%
4.Board warpage	Maximum of 0.02mm at the connector center, with both ends of the connector as reference points.
5.Cleaning conditions	Refer to "Nylon Connector Use Handbook".

Precautions

Precautions

Mating / un-mating

Please work according to the following operational procedure:

① Confirmation of insertion direction

Upon insertion, please check the front and rear of the connector at the cable side.

On the front side, the \triangle mark, HRS mark and the display of the pole number are stamped.

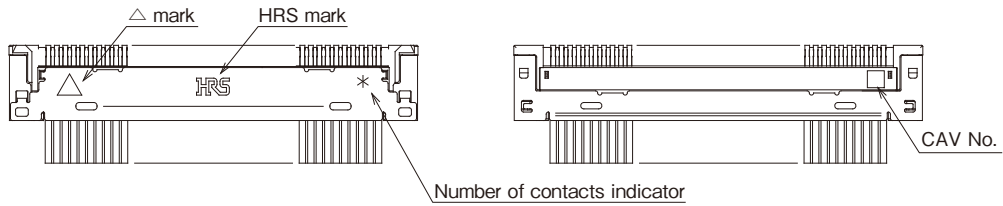

② Confirmation of temporary insertion

Please lay the plug into the receptacle gently and insert up to the temporary insertion position.

* If inserted up to the temporary insertion position, the connection can be correctly ensured.

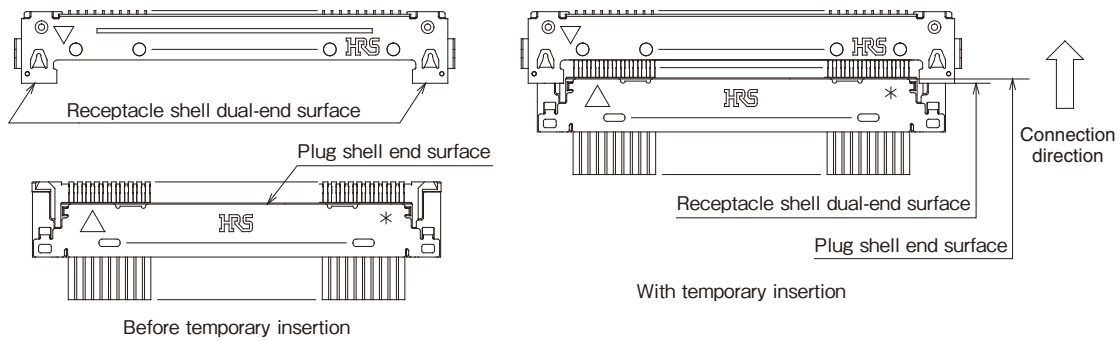

③ Confirmation of insertion

From the temporary insertion position, please push on both sides of the plug simultaneously and with equal force, to confirm the insertion.

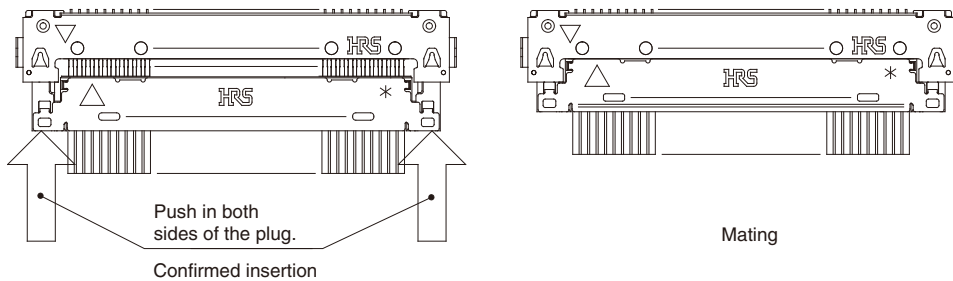

Precautions

un-mating

Use a dedicated extraction tool to un-mate the plug. Insert the tool under either end of the plug and pull as illustrated bellow.

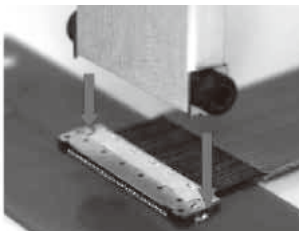

Insert the tool under either end of the plug.



pull out the plug
(for the horizontal direction)



Finish

- Do not mate / un-mate the connectors when receptacle is not mounted on the board.
- In the manual soldering process, don't carry out the flux coating which will cause a flux blister on the connector.
- Excessive scoop insertion or extraction may result in damage.

USA:

HIROSE ELECTRIC (U.S.A.), INC. Headquarters
 2688 Westhills Court, Simi Valley, CA 93065-6235
 Phone : +1-805-522-7958
 Fax : +1-805-522-3217
<http://www.hiroseusa.com>

USA:

HIROSE ELECTRIC (U.S.A.), INC. San Jose Office
 3255 Scott Boulevard, Building 7, Suite 101
 Santa Clara, CA 95054
 Phone : +1-408-253-9640
 Fax : +1-408-253-9641
<http://www.hiroseusa.com>

USA:

HIROSE ELECTRIC (U.S.A.), INC. Detroit Office (Automotive)
 37677 Professional Center Drive, Suite #100C
 Livonia, MI 48154
 Phone : +1-734-542-9963
 Fax : +1-734-542-9964
<http://www.hiroseusa.com>

THE NETHERLANDS:

HIROSE ELECTRIC EUROPE B.V.
 Hogehillweg #8 1101 CC Amsterdam Z-O
 Phone : +31-20-6557460
 Fax : +31-20-6557469
<http://www.hiroseeurope.com>

GERMANY:

HIROSE ELECTRIC EUROPE B.V. German Branch
 Herzog-Carl-Strasse 4 D-73760 Ostfildern
 (Scharnhauser Park)
 Phone : +49-711-4560-02-1
 Fax : +49-711-4560-02-299
<http://www.hirose.de>

UNITED KINGDOM:

HIROSE ELECTRIC EUROPE B.V. UK Branch
 22 Vincent Avenue, Crownhill Business
 Centre, Crownhill, Milton Keynes, MK8 0AB
 Phone : +44-1908-305750
 Fax : +44-1908-305768
<http://www.hirose.co.uk>

CHINA:

HIROSE ELECTRIC TRADING (SHANGHAI) CO., LTD.
 1601, Henderson Metropolitan, NO.300, East Nanjing
 Road, Huangpu District, Shanghai, China 200001
 Phone : +86-21-6391-3355
 Fax : +86-21-6391-3335
<http://www.hirose-china.com.cn>

CHINA:

HIROSE ELECTRIC TRADING (SHANGHAI) CO., LTD. Beijing Branch
 A1001, Ocean International Center, Building 56# East 4th
 Ring Middle Road, Chao Yang District, Beijing, 100025
 Phone : +86-10-5165-9332
 Fax : +86-10-5908-1381
<http://www.hirose-china.com.cn>

CHINA:

HIROSE ELECTRIC TECHNOLOGIES (SHENZHEN) CO., LTD.
 Room 09-13, 19/F, Office Tower Shun Hing Square, Di Wang Commercial Centre
 5002, ShenNanDong Road, ShenZhen City, Guangdong Province, 518008
 Phone : +86-755-8207-0851
 Fax : +86-755-8207-0873
<http://www.hirose-china.com.cn>

HONG KONG:

HIROSE ELECTRIC HONGKONG TRADING CO., LTD.
 Room 1001, West Wing, Tsim Sha Tsui Centre, 66
 Mody Road, Tsim Sha Tsui East, Kowloon, Hong Kong
 Phone : +852-2803-5338
 Fax : +852-2591-6560
<http://www.hirose-hongkong.com.hk>

TAIWAN:

HIROSE ELECTRIC TAIWAN CO., LTD.
 103 8F, No.87, Zhengzhou Rd., Taipei
 Phone : +886-2-2555-7377
 Fax : +886-2-2555-7350
<http://www.hirose-taiwan.com.tw>

KOREA:

HIROSE KOREA CO., LTD.
 1261-10, Jeoungwhang-Dong, Shihung-City,
 Kyunggi-Do 429-450
 Phone : +82-31-496-7000, 7124
 Fax : +82-31-496-7100
<http://www.hirose.co.kr>

SINGAPORE:

HIROSE ELECTRIC SINGAPORE PTE. LTD.
 10 Anson Road #26-1 International Plaza
 079903
 Phone : +65-6324-6113
 Fax : +65-6324-6123
<http://www.hirose-singapore.com.sg>

INDIA:

HIROSE ELECTRIC SINGAPORE PTE. LTD. Bangalore Liaison office
 Unit No.03, Ground Floor, Explorer Building International Tech
 Park Whitefield Road, Bangalore 560066 Karnataka, India
 Phone : +65-6324-6113
 Fax : +65-6324-6123
<http://www.hirose-singapore.com.sg>

INDIA:

HIROSE ELECTRIC SINGAPORE PTE. LTD Delhi Liaison Office
 Suite No. 606 5th Floor SB Tower 1A/1 Sector
 16 A Filmcity Noida 201301 Uttar Pradesh-India
 Phone : +91-120-4804917
 Fax : +91-120-4804949
<http://www.hirose.com/sg/>

MALAYSIA:

HIROSE ELECTRIC SINGAPORE PTE. LTD (Representative office)
 1-10-07, Suntech @ Penang Cybercity (1164), Lintang
 Mayang Pasir 3, 11950, Bayan Baru, Penang, Malaysia.
 Phone : +604-619-2564
 Fax : +604-619-2574
<http://www.hirose.com/sg/>



HIROSE ELECTRIC CO.,LTD.

6-3, Nakagawa Chuoh-2-Chome, Tsuzuki-Ku, Yokohama-Shi 224-8540, JAPAN
 TEL: +81-45-620-3526 Fax: +81-45-591-3726
<http://www.hirose.com>
<http://www.hirose-connectors.com>