

4

3

2

1

THIS DRAWING IS UNPUBLISHED. RELEASED FOR PUBLICATION - , - .
 © COPYRIGHT - By - ALL RIGHTS RESERVED.

LOC	DIST	REVISIONS					
		P	LTR	DESCRIPTION	DATE	DWN	APVD
HM	00		B	REV ECO-15-002162	11FEB2015	GG	RA

- 1. DIMENSIONS ARE MAXIMUM.
- 2. MATERIAL: ADAPTER- POLYCARBONATE MOLDING COMPOUND, 94V-0 RATED, SEE TABLE FOR COLOR. TUBING- BLACK POLYOLEFIN.
- 3. KIT SHIPPED NOT ASSEMBLED.
- 4. KIT INCLUDES TUBING - NOT SHOWN.

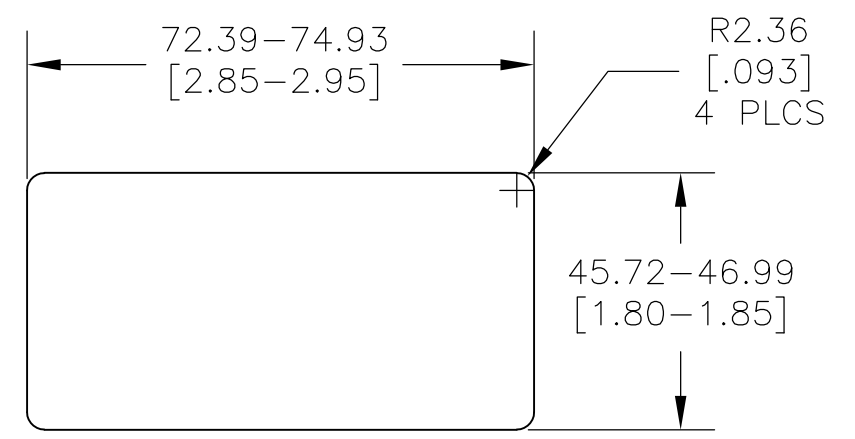
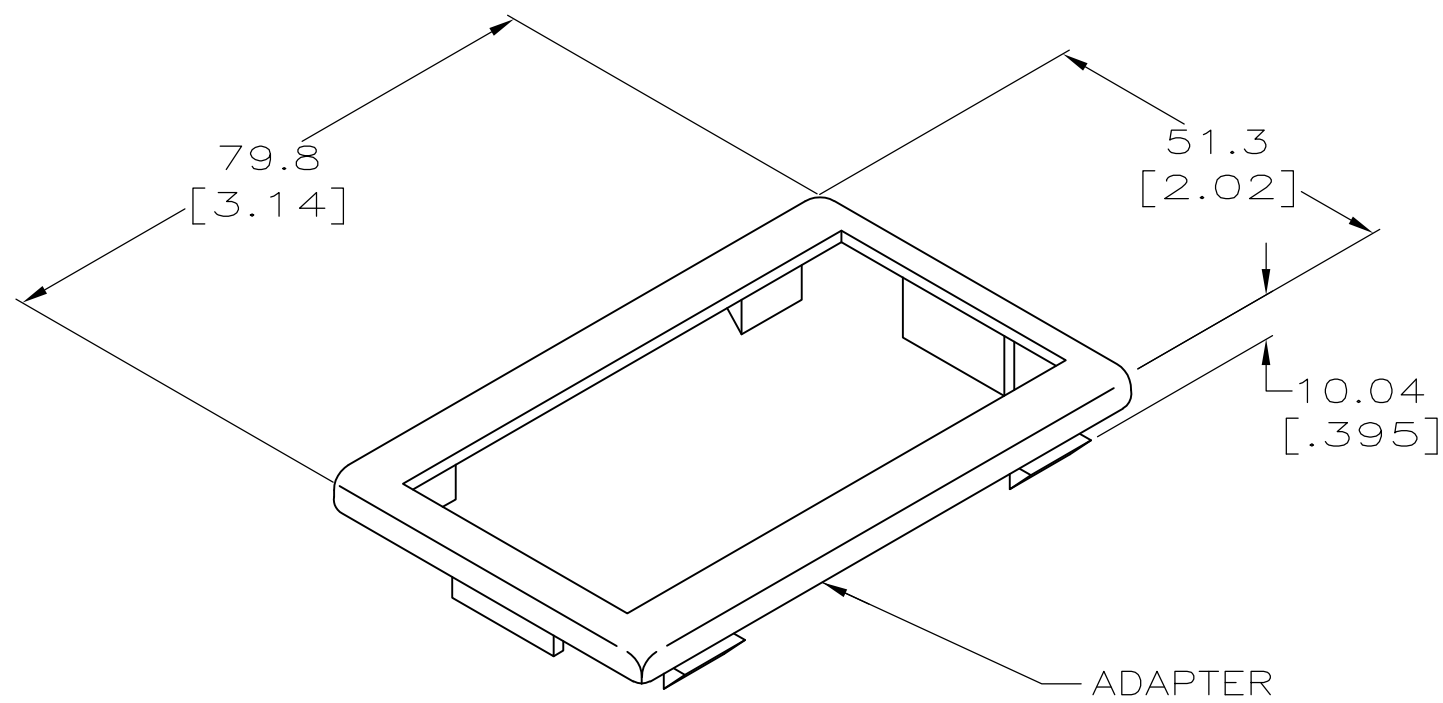

RECOMMENDED PANEL CUTOUT
 SCALE: 1:1

NEMA GRAY	558493-4
SOFT WHITE	558493-2
BLACK	558493-1
COLOR	PART NO.

THIS DRAWING IS A CONTROLLED DOCUMENT.		DWN K. TILLMAN/UTA 3-29-94	TE Connectivity																
DIMENSIONS: MM [INCHES]		CHK D. HUSSEY 3-29-94																	
TOLERANCES UNLESS OTHERWISE SPECIFIED:		APVD J. KILPATRICK 3-29-94	NAME ADAPTER KIT, HERMAN MILLER, FLEXMODE																
<table border="0"> <tr> <td>0 PLC</td> <td>± -</td> <td rowspan="5">1</td> </tr> <tr> <td>1 PLC</td> <td>± -</td> </tr> <tr> <td>2 PLC</td> <td>± -</td> </tr> <tr> <td>3 PLC</td> <td>± -</td> </tr> <tr> <td>4 PLC</td> <td>± -</td> </tr> <tr> <td>ANGLES</td> <td>± -</td> <td></td> </tr> </table>		0 PLC	± -	1	1 PLC	± -	2 PLC	± -	3 PLC	± -	4 PLC	± -	ANGLES	± -		PRODUCT SPEC D. MARGO 3-29-94	APPLICATION SPEC		
0 PLC	± -	1																	
1 PLC	± -																		
2 PLC	± -																		
3 PLC	± -																		
4 PLC	± -																		
ANGLES	± -																		
MATERIAL		408-9957	SIZE	CAGE CODE	DRAWING NO	RESTRICTED TO													
FINISH		-	A3	00779	C-558493	-													
CUSTOMER DRAWING			SCALE	SHEET	REV														
			1:1	1 OF 1	B														