

LOC	DIST	REVISIONS					
HM	00	P	LTR	DESCRIPTION	DATE	DWN	APVD
		A		RLSD - NSD03-127	23DEC03	GG	CD
		B		REV: EC 0B40-0023-04	17FEB04	GG	MD
		C		REV: ECO-10-013215	23JUN2010	GG	DC

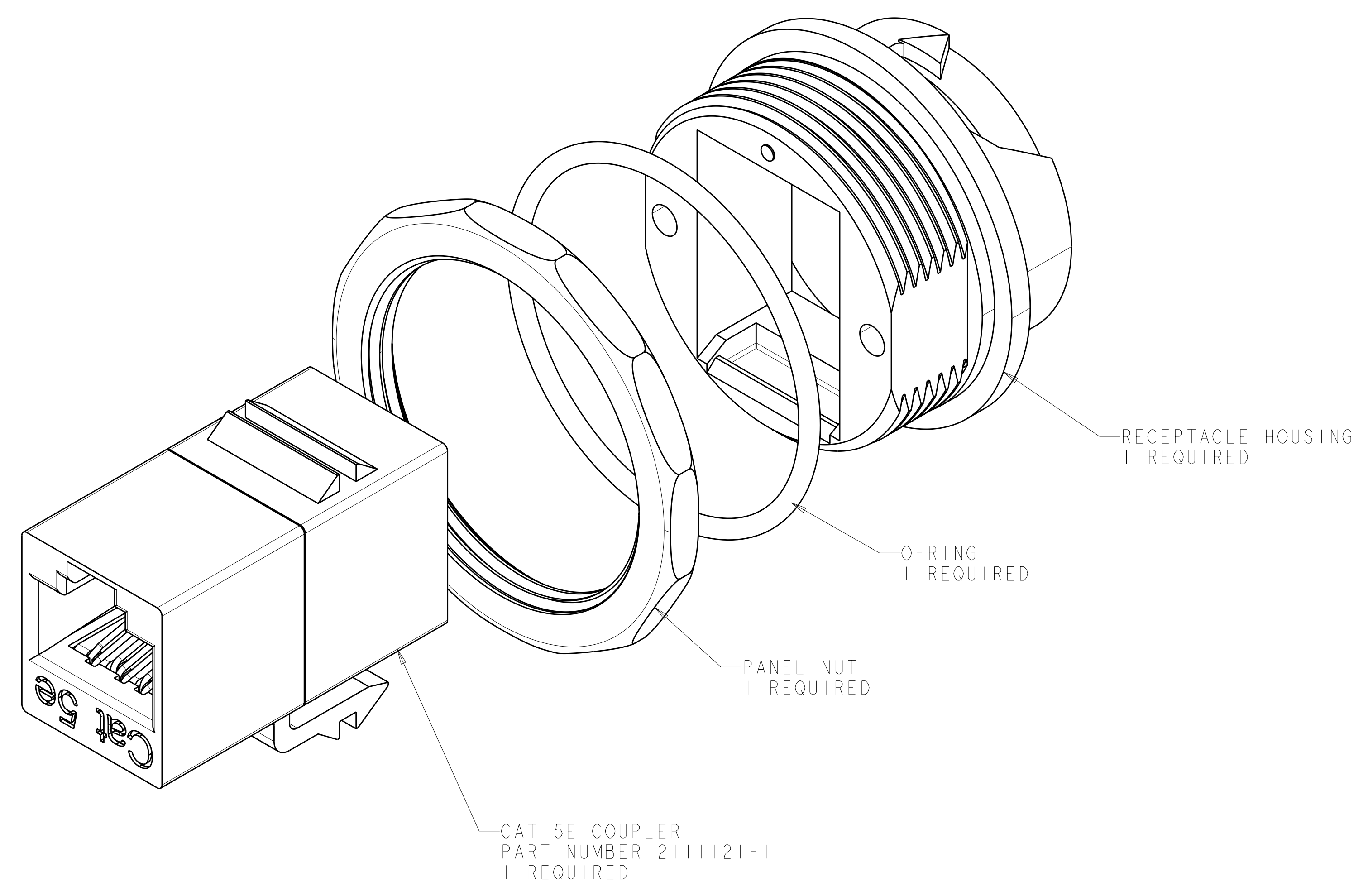

- 1 MATERIAL: COUPLER HOUSING - ABS, 94V-0 RATED.
RECEPTACLE HOUSING - PBT, 94V-0 RATED.
O-RING SEALS - BUNA.
PANEL NUT - NICKEL PLATED BRASS.
- 2 SUGGESTED PANEL CUTOUT OPENING.
- 3 PACKAGED ONE COUPLER, ONE O-RING,
ONE ETHERSEAL HOUSING, AND ONE PANEL NUT,
PER POLYBAG. KIT SHIPPED NOT ASSEMBLED.

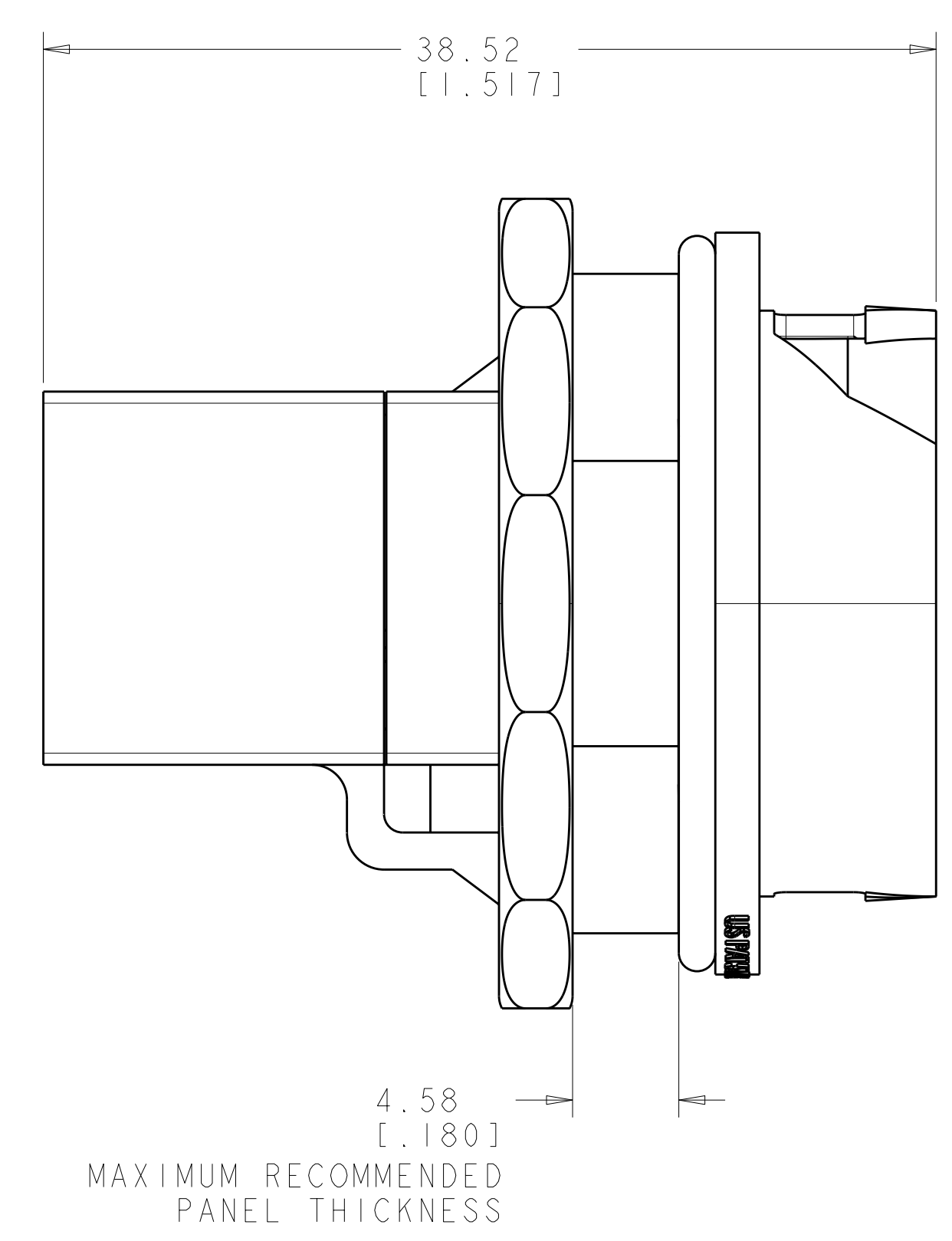
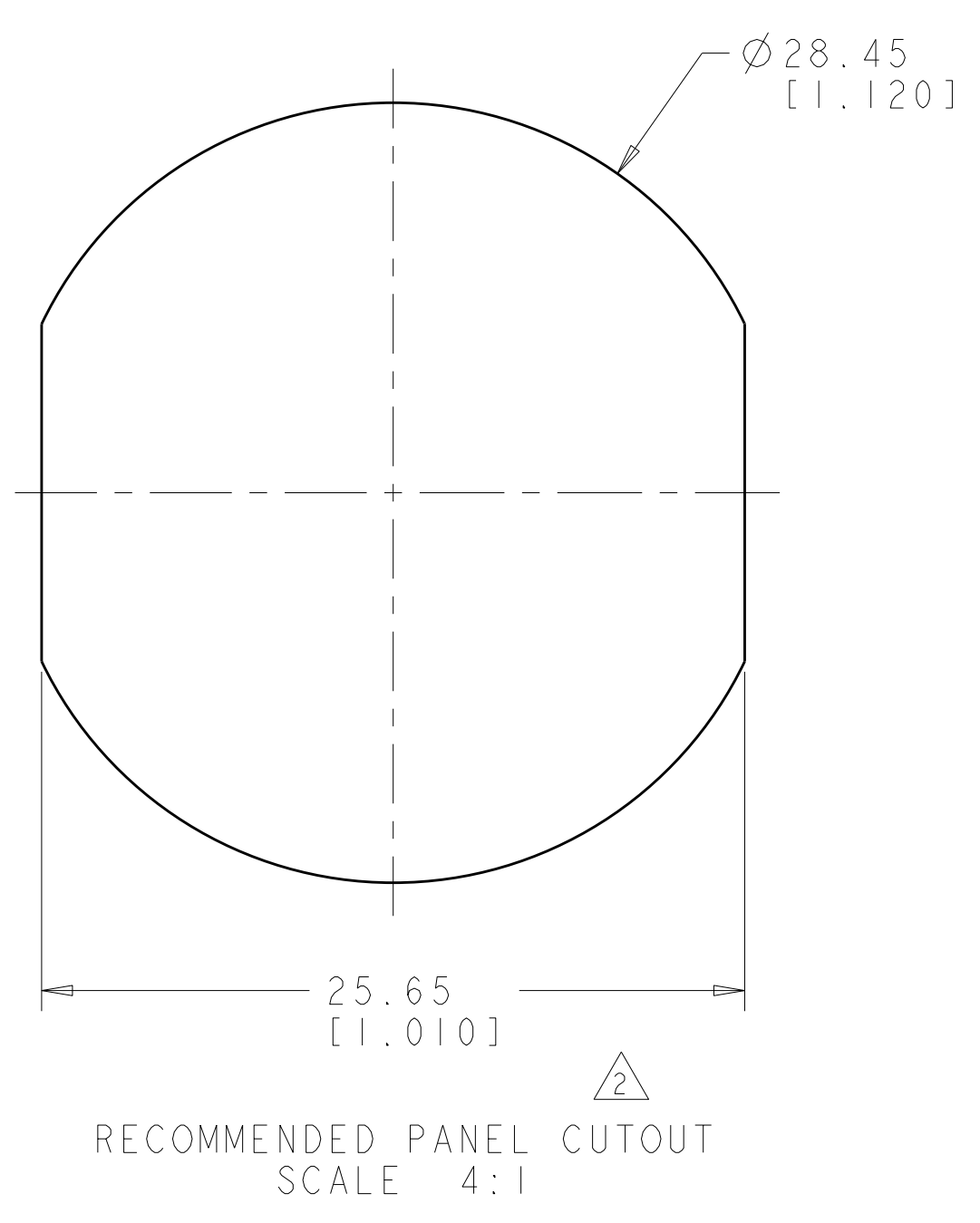

BLACK	1479599-2
COLOR	PART NUMBER

<small>THIS DRAWING IS UNPUBLISHED. RELEASED FOR PUBLICATION. ALL RIGHTS RESERVED. THIS DRAWING IS UNPUBLISHED. RELEASED FOR PUBLICATION. ALL RIGHTS RESERVED. THIS DRAWING IS UNPUBLISHED. RELEASED FOR PUBLICATION. ALL RIGHTS RESERVED.</small>		DWN S. GARRETT	23DEC03	Tyco Electronics Harrisburg, PA 17105-3608
DIMENSIONS: MM [INCHES]		CHK C. DOOLEY	23DEC03	
TOLERANCES UNLESS OTHERWISE SPECIFIED: 0 PLC ± 1 PLC ± 2 PLC ± 3 PLC ± 4 PLC ± ANGLES ±		APVD C. DOOLEY	23DEC03	NAME KIT, ETHERSEAL, UTP, CAT 5E COUPLER, FRONT MOUNT, BLACK
MATERIAL:		PRODUCT SPEC: APPLICATION SPEC: WEIGHT:		SIZE CAGE CODE DRAWING NO RESTRICTED TO A 00779 C-1479599
FINISH:		CUSTOMER DRAWING		SCALE 4:1 SHEET 1 OF 1 REV C