

Selection Guide

| Part No. | Dice | Lens Type | Iv (ucd) [1] @ 10mA | | Description |
|---------------------|--------------|----------------|------------------------|------|-----------------------------------|
| | | | Min. | Typ. | |
| ACSC56-41PBWA/A-F01 | Blue (InGaN) | WHITE DIFFUSED | 1900 | 9000 | Common Cathode, Rt. Hand Decimal. |

Note:

1. Luminous intensity/ luminous Flux: +/-15%.

Electrical / Optical Characteristics at TA=25°C

| Symbol | Parameter | Device | Typ. | Max. | Units | Test Conditions |
|-----------------------|--------------------------|--------|------|------|-------|---------------------------|
| λ_{peak} | Peak Wavelength | Blue | 468 | | nm | I _F =20mA |
| λ_D [1] | Dominant Wavelength | Blue | 470 | | nm | I _F =20mA |
| $\Delta\lambda_{1/2}$ | Spectral Line Half-width | Blue | 21 | | nm | I _F =20mA |
| C | Capacitance | Blue | 100 | | pF | V _F =0V;f=1MHz |
| V _F [2] | Forward Voltage | Blue | 3.2 | 4.0 | V | I _F =20mA |
| I _R | Reverse Current | Blue | | 10 | uA | V _R =5V |

Notes:

1. Wavelength: +/-1nm.

2. Forward Voltage: +/-0.1V.

Absolute Maximum Ratings at TA=25°C

| Parameter | Blue | Units |
|---------------------------------|----------------|-------|
| Power dissipation | 120 | mW |
| DC Forward Current | 30 | mA |
| Peak Forward Current [1] | 100 | mA |
| Reverse Voltage | 5 | V |
| Operating / Storage Temperature | -40°C To +85°C | |

Note:

1. 1/10 Duty Cycle, 0.1ms Pulse Width.



Blue

ACSC56-41PBWA/A-F01

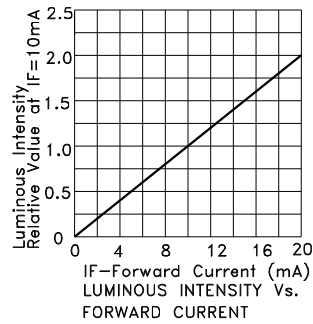

ACSC56-41PBWA/A-F01

Reflow Soldering Profile For Lead-free SMT Process.



NOTES:

1. We recommend the reflow temperature 245°C(+/-5°C). The maximum soldering temperature should be limited to 260°C.
2. Don't cause stress to the epoxy resin while it is exposed to high temperature.
3. Number of reflow process shall be 2 times or less.

Recommended Soldering Pattern (Units : mm; Tolerance: ± 0.15)

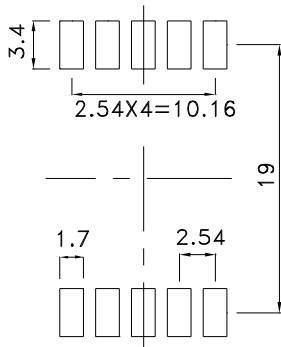

Reel Dimension

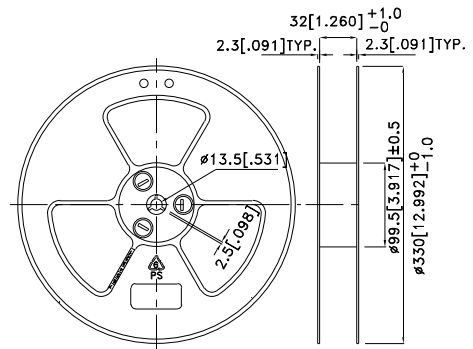

Tape Specifications (Units : mm)

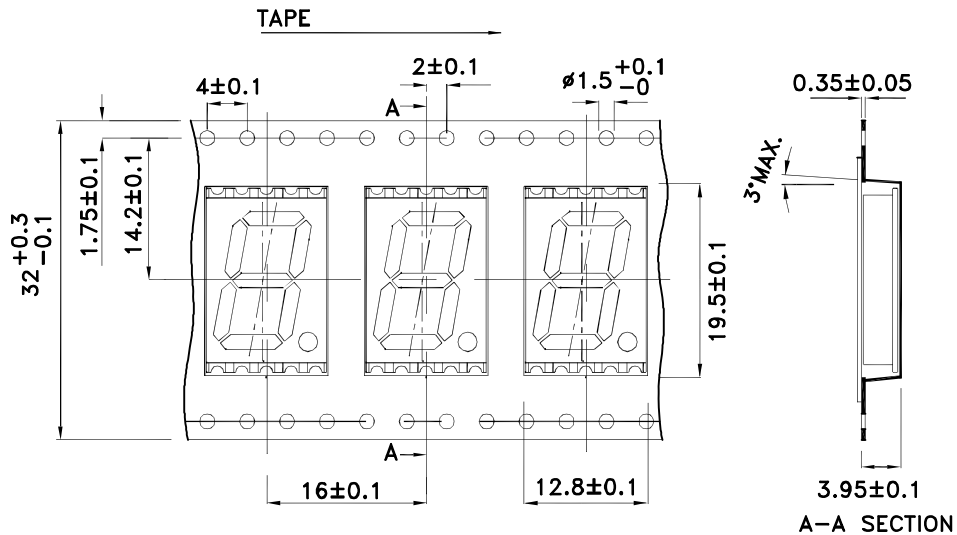

PACKING & LABEL SPECIFICATIONS

ACSC56-41PBWA/A-F01

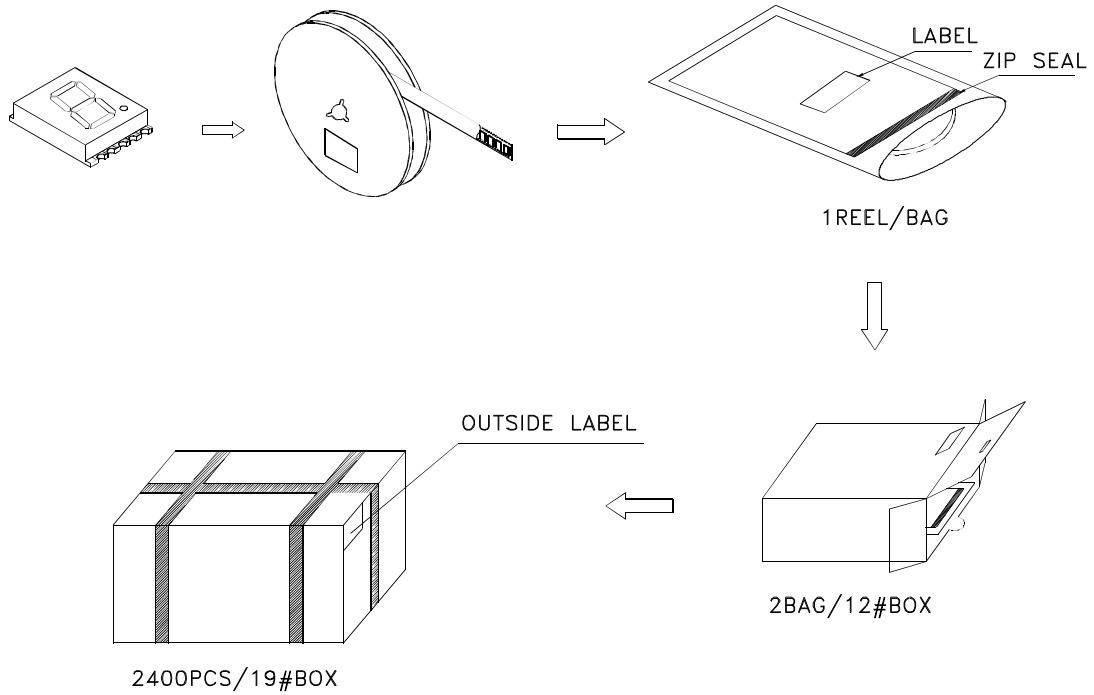

Inside Label Paste On The Tape

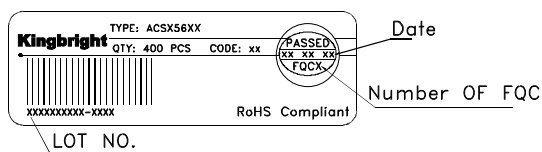

Outside Label Paste On The Bag

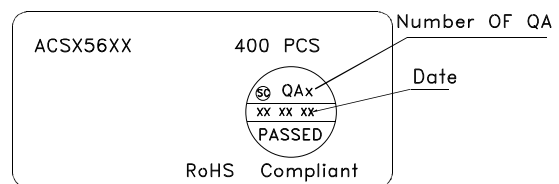

Outside Label Paste On The 19#Box

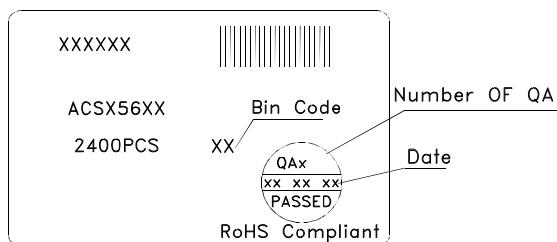

Outside Label Paste On The 12#Box

